

Design and Implementation of Frequency Generator of a Portable Sound Wave Fire Extinguisher

Hassan Amin Osseily, Hussein El Husseiny, Hilal Sweidan

Electrical and Electronic department

The International University of Beirut (BIU), Lebanese International University (LIU), Al Maaref University (MU)

Received Date: 25 November 2020

Revised Date: 31 December 2020

Accepted Date: 06 January 2020

Abstract — This paper aims to design and implement a circuit of frequency generator of a portable fire extinguisher based on sound waves. The intervention of firefighters is one of the most prominent situations that put their lives at risk, and it urges us to consider finding new ways to extinguish fires. Even though traditional techniques have high efficiency to extinguish fires, they have many drawbacks such as causing damages and leaving toxic materials polluting the environment. Proceeding from the nature of sound as a mechanical wave that propagates in different mediums, this paper shows that sound waves may be used in the firefighting field where the frequency generator is the main part of this new firefighting device.

Keywords—Pulse Width Modulation (PWM), WaveLength, Velocity, Carbon Dioxide CO₂.

I. INTRODUCTION

Fire is one of the most common accidents causing death worldwide. In 2015, the Electrical Safety Foundation International (ESFI) posted an article about the facts and the statistics of home electrical fires in the United States: fires at home caused by electrical faults are estimated for 51,000 fires each year. About 500 deaths and 1,400 injuries are the results of home electrical fires. The property damage each year is estimated at \$1.3 billion. [1] Four elements must be present for the fire to exist: heat, fuel, oxygen, and chain reaction. In a fire, flammable substances are burning, not oxygen.

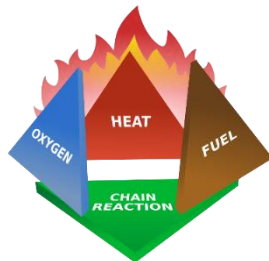

Figure 0. The fire tetrahedron

Oxygen is an oxidizer. When a mix of combustible material with a sufficient quantity of an oxidizer such as oxygen gas O₂ is exposed to a temperature above the oxidizer/fuel mix's flashpoint, the fire started. [2,3]

The main ways to stop fire are: removing the fuel, removing the heat, and removing the oxygen [4,5]

II. FIRE EXTINGUISHER BASED ON SOUND WAVES

As known, sound waves are classified as mechanical waves. By definition, a sound wave needs a medium to propagate [6,7,8]; it depends on the medium's particles to move. Particles in the air vibrate back and forth, transferring the sound's energy from one particle to another, acting as a mechanical wave.

Since fire is based on oxygen molecules in the air, a sound wave oscillates between high and low pressure, creating a vacuum, which helps to move the oxygen molecules away from the flame, putting out the fire. The block diagram of this project shows the principal hardware parts of the sound wave fire extinguisher device. The flow of the process from the microcontroller to the frequency generator is right up to the speaker's vortex nozzle.

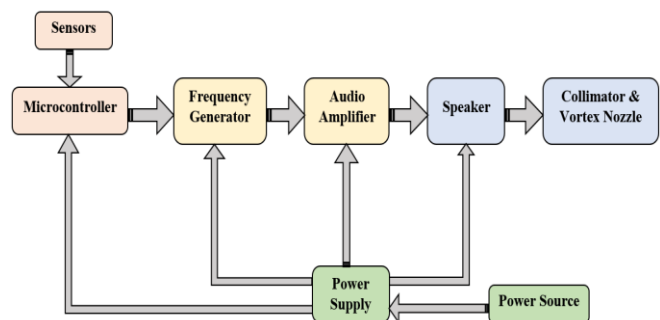

Figure 2. The block diagram of the Sound waves fire extinguisher.

The sound emitted from the speaker is characterized by its frequency and amplitude. For that



reason, it is obligatory to use a frequency generator and an audio amplifier [9,10,11]. After the sound comes out of the speaker, the acoustic wave should be directed to be more effective in a specific direction. That is why a collimator is connected to the speaker. A power supply unit is used to feed the different parts of the device. A microcontroller connected to some sensors to detect fire will decide the operation of the device.

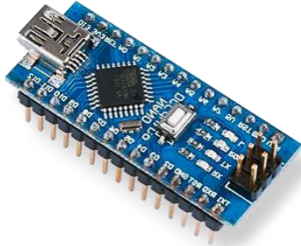

Figure 0. Arduino Nano microcontroller.

Using this Arduino, the sound wave fire extinguisher device can get the order to start. This Arduino also has the feature to generate a sine wave signal with any frequency between 1Hz and 20 kHz; therefore, it can take the frequency generator's place. To operate an automatic fire suppression system, detection sensors must be used. There are two types of detection: mechanical and electrical. The mechanical components such as a fusible link fire damper or a frangible bulb sprinkler depend on the increase in temperature to release the extinguishing agents. Electrical sensors are thermal sensors that detect high temperature or radiation sensors that detect a flame's presence. In this project, since the extinguisher should start just after the fire, it will be better to use a flame sensor connected to the Arduino. The flame sensor is a device that receives electromagnetic radiation, which allows it to detect the wavelength between 760 nm and 1100 nm from the light source. It has high photosensitivity, very high response time, its detection angle is 60°, and it can be detected from a distance of 1 meter. [16]

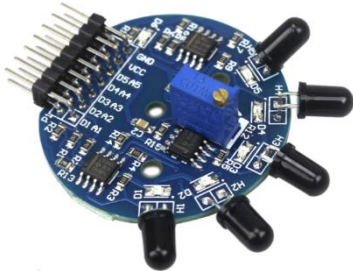

Figure 4. Five-way flame sensor.

III. FREQUENCY GENERATOR

Sound is a longitudinal mechanical wave, which can be represented as a sinusoidal wave. It has its specific frequency, wavelength, and amplitude. Since the velocity of sound in air is constant at 344 m/s, the relation between the distance (wavelength λ) traveled during a period T is inversely proportional to the frequency f .

$$\lambda = \frac{v}{f} \tag{1}$$

From equation (1), when the frequency decreases, the wavelength increases. As mentioned in the introduction, the wavelength is the length of the compression and the rarefaction. The suppression of a fire using sound waves depends on the fire's oxygen particles' push and pull. Therefore, it is to have a large wavelength; consequently, a low frequency will be more preferable.

After some trials and experiments on the effect of sound frequency on the flame, the range of 30 Hz to 60 Hz was more efficient [12,13,14]. Therefore, the frequency generator circuit should generate a signal between these frequencies. A function generator using Arduino is the method that will be used to produce a waveform signal. The Arduino will produce four waveforms: square, triangular, sine, and sawtooth. Apart from that, the generator can also be accompanied by frequency control. A color OLED display will show the frequency and the type of the signal. A rotary encoder is connected to the Arduino to change the frequency. The PWM signal on the Arduino is a digital square wave. An RC circuit could be connected to the PWM output to get a pure sine wave signal.

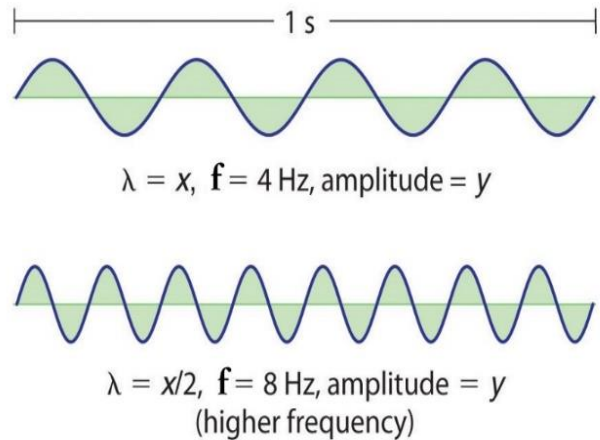

Figure 5. The relation between the frequency and the wavelength.

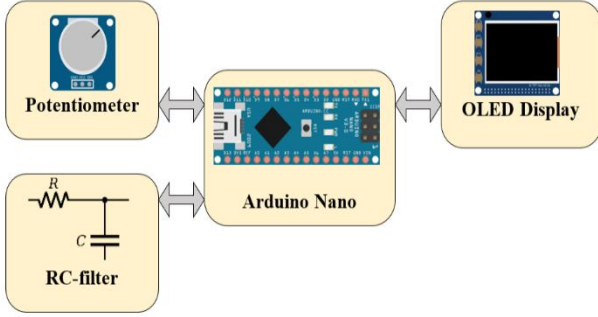

Figure 6. Function generator block diagram.

To find the required voltage to supply an amplifier, it is necessary to find its peak output voltage when it is connected to the speaker. Each speaker has an impedance R_L in Ohm and an average output power P_o in Watt. The peak output voltage of the amplifier V_{Opeak} is calculated from the following equation:

$$V_{Opeak} = \sqrt{2 \times R_L \times P_o} \quad (2)$$

The amplifier adds the energy converted from the power supply to the signal, and it increases the signal's amplitude from the input to the output. When implementing an amplifier, a minimum value of the gain A_v must be set, and it depends on the input voltage V_{in} , the output power P_o , and the speaker impedance R_L .

$$A_v = \frac{\sqrt{R_L \times P_o}}{V_{in}} \quad (3)$$

The cutoff frequency of the filter is the frequency that decides the work of the filter. Any frequency below the low cutoff frequency will be muted in a high pass filter. While, in the low pass filter, any frequency above the cutoff will be muted. The combination of the two filters will set the bandwidth.

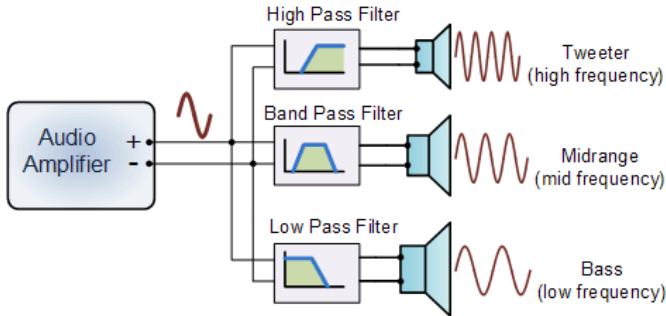

Figure 7. Audio amplifier and filter types.

IV. COLLIMATOR AND VORTEX NOZZLE

Air vortex cannon is an instrument that looks like a collimator ending up with a vortex nozzle. In general, the

collimator is used to limit the direction of a wave or particles. In the vortex cannon, a quick force is applied to air molecules by the speaker's diaphragm, accelerating the molecules to move and push them to the cannon's end. The only way for the particles to escape from the closed canon is to pass through the opening, forming a jet of air that flows out of the vortex cannon.

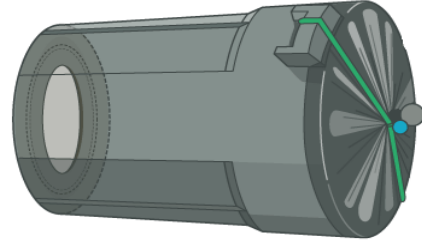

Figure 8. Air vortex cannon.

Due to the vortex ring phenomenon, which is also called a toroidal vortex, the jet of air flowing out from the cannon's nozzle will flow around an idealized ring and keep spinning, as shown in the figure below. The air around the vortex has a high pressure that allows the ring to stay stable and keep its shape while traveling forward.

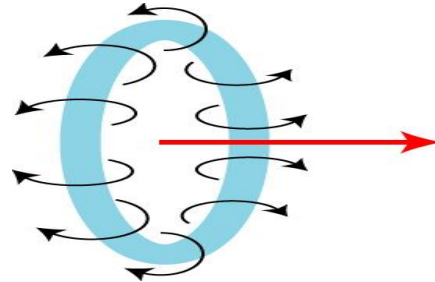

Figure 9. Vortex ring.

The main objective of using vortex cannon is to increase the distance traveled by the air particles. The ring shape can carry the particles for a distance greater than the normal flow of air. In addition, it will help it to conserve its kinetic energy for a longer distance.

V. DESIGN OF THE FREQUENCY GENERATOR CIRCUIT

As we know, the outputs of an ATmega328 microcontroller are either digital outputs or PWM output. It will be easy to produce a square wave by generating an ON/OFF signal on one of its digital output pins with a 50% duty cycle. Moreover, the work will be more difficult when it comes to generating a sine wave signal. For this reason, we will use an R-2R Ladder Digital to Analog Converter. Since it is not possible to generate a sine wave directly from a pin of an Arduino, a digital to analog converter must be used. R-

2R Ladder is a circuit that contains only two values of resistors, such that if the first value is R , then the other should be equal to $2R$. That is why it is called the R-2R circuit. The general circuit shows several repetitive stages connected to a number of bits of the circuit board, as shown.

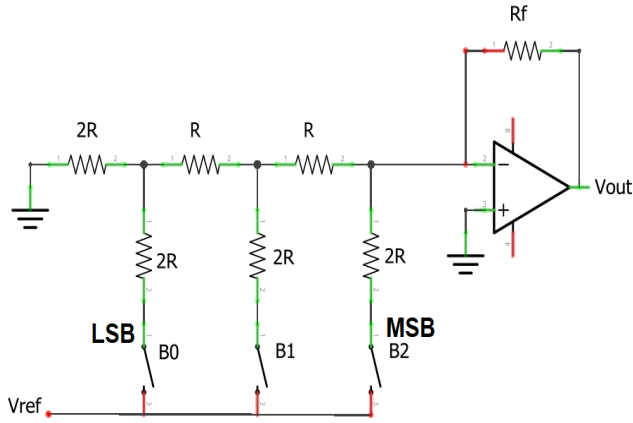

Figure 10. R-2R ladder circuit.

The circuit in figure 10 is a simple ladder R-2R circuit using 3 bits. Where B_0 is the least significant bit, and B_2 is the most significant bit. The output voltage V_{out} will change according to the connected bits. Therefore, the number of levels of output is related to the number of bits according to the following equation:

$$\text{Number of levels} = 2^{\text{Number of bits}}$$

The more the number of bits is higher, the more the signal becomes smooth and free of noise.

Let us start by showing the calculation, using the Thevenin method, of the output voltage for 3 bits R-2R ladder circuit, of binary code 001, where the only B_0 is connected to the voltage reference.

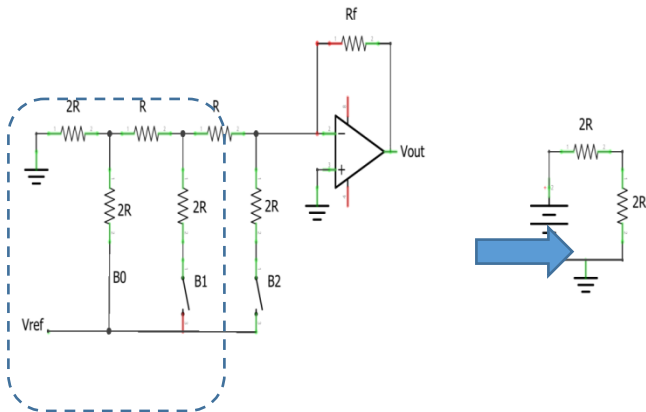

Figure 11. R-2R ladder circuit with B_0 connected.

The Thevenin terminal voltage is equal to:

$$V_{th} = \frac{2R \times V_{ref}}{2R + 2R} = \frac{V_{ref}}{2} \quad (5)$$

To find the equivalent resistance, the voltage reference is assumed to be 0. Then the two resistance ($2R$) are in parallel. Then the equivalent resistance is equal to:

$$R_{eq} = \frac{2R \times 2R}{2R + 2R} = R \quad (6)$$

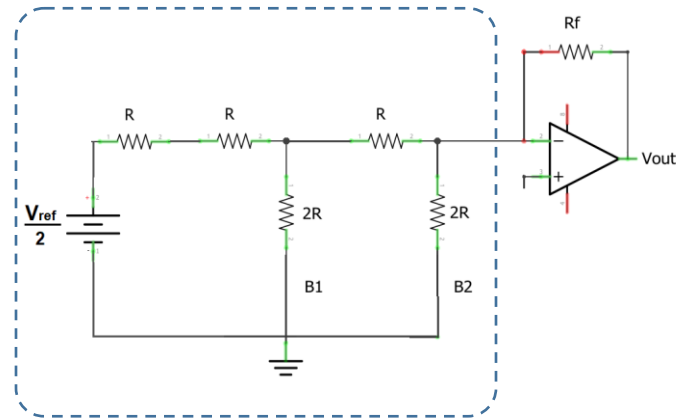

Figure 12. R-2R ladder equivalent circuit.

Now, we find the equivalent circuit of the part inside the rectangle shape. The two series resistances R are in parallel with the $2R$ resistance; therefore, the Thevenin voltage will become:

$$V_{th} = \frac{2R \times \frac{V_{ref}}{2}}{2R + 2R} = \frac{V_{ref}}{4} \quad (7)$$

Same as in equation (6), the equivalent resistance will be equal to R .

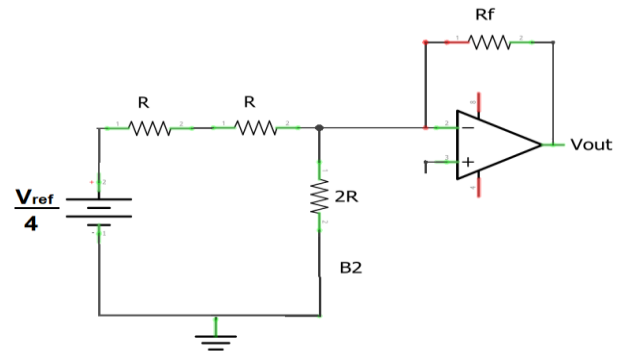

Figure 13. The equivalent circuit after replacing the new Thevenin circuit.

The final Thevenin voltage is calculated as:

$$V_{th} = \frac{2R \times \frac{V_{ref}}{4}}{2R+2R} = \frac{V_{ref}}{8} \quad (8)$$

Furthermore, the final equivalent resistance is equal to:

$$R_{eq} = \frac{2R \times 2R}{2R+2R} = R \quad (9)$$

The same calculation is done when B₁ is connected to V_{ref} while B₀ and B₂ are connected to the ground: the Thevenin voltage obtained is equal to V_{ref}/4.

When B₂ is connected to V_{ref} while B₀ and B₁ are connected to the ground: the Thevenin voltage obtained is equal to V_{ref}/2.

In conclusion, in a 3 bits R-2R ladder circuit, the output voltage of the circuit before it enters the amplification will be calculated using the following formula:

$$V_{th} = V_{ref} \left(\frac{B_0}{8} + \frac{B_1}{4} + \frac{B_2}{2} \right) \quad (10)$$

Where B₀, B₁, and B₂ are either 0 or 1, depending on whether the bit is connected to V_{ref} or not. A 3 bits R-2R ladder circuit will give us 8 levels of voltages at the output. The following table shows the different output voltage values when we connect the bits to the reference voltage.

Table 0I. The different output voltages in an R-2R Ladder circuit

B ₂ B ₁ B ₀	Equation	V _{th}
000	$V_{th} = V_{ref} \left(\frac{0}{8} + \frac{0}{4} + \frac{0}{2} \right)$	0
001	$V_{th} = V_{ref} \left(\frac{1}{8} + \frac{0}{4} + \frac{0}{2} \right)$	$\frac{V_{ref}}{8}$
010	$V_{th} = V_{ref} \left(\frac{0}{8} + \frac{1}{4} + \frac{0}{2} \right)$	$\frac{V_{ref}}{4}$
011	$V_{th} = V_{ref} \left(\frac{1}{8} + \frac{1}{4} + \frac{0}{2} \right)$	$\frac{3V_{ref}}{8}$
100	$V_{th} = V_{ref} \left(\frac{0}{8} + \frac{0}{4} + \frac{1}{2} \right)$	$\frac{V_{ref}}{2}$
101	$V_{th} = V_{ref} \left(\frac{1}{8} + \frac{0}{4} + \frac{1}{2} \right)$	$\frac{5V_{ref}}{8}$
110	$V_{th} = V_{ref} \left(\frac{0}{8} + \frac{1}{4} + \frac{1}{2} \right)$	$\frac{3V_{ref}}{4}$
111	$V_{th} = V_{ref} \left(\frac{1}{8} + \frac{1}{4} + \frac{1}{2} \right)$	$\frac{7V_{ref}}{8}$

Using the ATmega328 microcontroller, we can connect the R-2R circuit to a specific number of pins, and each pin will control a bit of the circuit. When we turn it ON,

the bit will become 1, and a new voltage value will be produced. In this way, and with the change of time, a signal will be produced.

As shown in the following figure, the number of bits affects the purity of the signal produced.

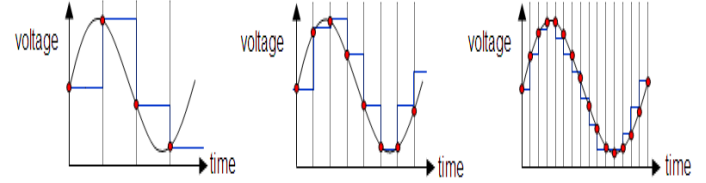

Figure 14. The effect of the number of bits on the signal waveform.

In our frequency generator circuit, 8 bits will be used. Therefore, the number of voltage levels is equal to 256 values.

The ATmega328 is programmed by a code that contains different functions; each function can be called by the user using the rotary encoder. The user can push on the rotary encoder and change the type of the signal. Once the signal is chosen, the microcontroller sends a sequence of the 8-bit number to the ATmega328 pins repetitively on a specific period depending on the frequency chosen. A 256 bytes array stores the waveform to be sent to the pins, in other words, to the R-2R circuit.

The waveform is formed of a number of phases; each has a specific value of output voltage. When combined, a signal is formed. Changing the frequency of the signal will change the time by which the phase is incremented. Since the crystal oscillator connected to the Arduino has a 16MHz frequency crystal, and since it takes 42 clock cycles to set the pins, the sampling rate is equal to 381KHz. Which lead to an accuracy of 0.089 mHz of the frequency. [24]

The R-2R circuit has a high impedance that leads to a drop in the voltage. Therefore, the output should be amplified using the LM358 op-amp. Note that feeding the op-amp by 20V can generate a signal with a voltage up to 18V. [24]

An LCD screen is the electronic part module that will allow us to display the frequency and the type of signal that we chose. When the user changes the signal or the frequency, the values change on the LCD. Electronic design engineers usually use the Proteus software to create a schematic for a circuit and test it before the print stage. Using this software, the frequency generator circuit is drawn, and a simulation is done to make sure that the circuit generates different types of signals on different frequencies.

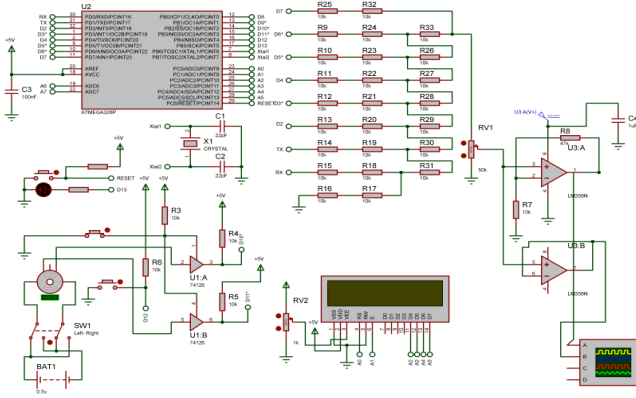

Figure 15. Frequency Generator Circuit on Proteus.

The first test of the portable sound wave fire extinguisher was made using a 40-Watt speaker to see its effect on a candle's flame. This section will follow some steps to build a 40-watt amplifier using the LM3886 audio chip amplifier, and we will calculate the component values. This amplifier can handle up to a 68-watt speaker. To build an amplifier for a 500-watt speaker, we have to move into a circuit based on the transistors such as MOSFETs. However, the same considerations should be taken. To find the required voltage to supply an amplifier, it is necessary to find its peak output voltage when it is connected to the speaker. Each speaker has an impedance R_L in Ohm and an average output power P_o in Watt. The peak output voltage of the amplifier V_{Opeak} is calculated from the following equation:

$$V_{Opeak} = \sqrt{2 \times R_L \times P_o} \quad (11)$$

Therefore, to build an amplifier for 40 watts with the 6-Ohm speaker, the peak output voltage is:

$$V_{Opeak} = \sqrt{2 \times 6 \times 40} = 21.9 \text{ V}$$

The voltage that the amplifier needs from the supply to obtain the desired output power depends on the voltage drop across the LM3886 with mostly 4V. Also, the transformer regulation can be given by the datasheet, which is 6% here. The formula to be used to calculate the maximum supply voltage:

$$V_{max\ supply} = \pm(V_{peak} + V_{od})(1 + Regulation) \quad (1.1)$$

$$V_{max\ supply} = \pm(21.9 + 4)(1 + 0.06) \quad (1.1) \\ = \pm 30.2 \text{ V}$$

The LM3886 generates a large heat value to avoid its damage; a heat sink should be used.

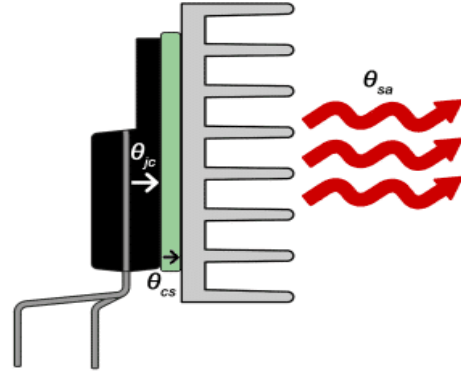

Figure 16. Heat sink connected to the IC.

We have to find the proper values for the amplifier circuit components after calculating the power supply voltage. The minimum gain of the amplifier depends on the input voltage V_{in} which is the audio source from the phone (1V), speaker impedance, and the output power using the formula:

$$A_v \geq \frac{\sqrt{R_L \times P_o}}{V_{in}} \quad (12)$$

$$A_v \geq \frac{\sqrt{6 \times 38.2}}{1}$$

$$\text{Then } A_v \geq 15.1$$

The resistors connected to the LM3886 decide the value of the gain. Here we will assume a gain of 21. We will calculate the values of the resistors R_f by taking a value of $R_i = 1\text{KOhm}$.

$$R_f = R_i(A_v - 1) \quad (13)$$

$$R_f = 1000(21 - 1)$$

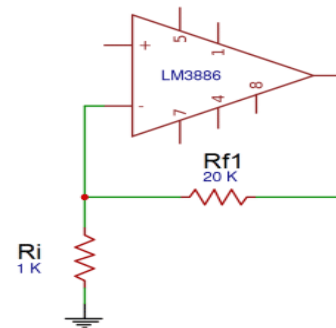

Figure 17. Gain setting.

After setting R_f and R_i to obtain the desired gain, two new resistors have to be added, R_{in} and R_b , to balance the input bias current. LM3886 has an inverting input (pin10) and a non-inverting input (pin9). If the currents entering these two inputs are different, it will produce a voltage across them. In other words, it will produce noise. Therefore, we add to the non-inverting input two resistors R_b and R_{in} such that their summation is approximately equal to R_f , which is connected to the inverting input. Thus, the currents entering the two inputs are equal, as shown in the following figure.

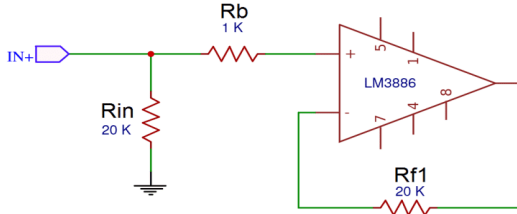

Figure 18. Balancing input bias currents.

As known, any DC will be blocked by a capacitor. Since the audio signal to be amplified has the form of an AC wave, any DC in the audio will be blocked by a capacitor C_{in} connected at the input directly. C_{in} and R_{in} will form together an RC filter that will determine the lowest frequency entering the amplifier. The value of C_{in} is calculated basing on the cutoff frequency F_c which will be assumed to be 1.69 Hz (to get a value of C_{in} that can be found in the market) using the following formula:

$$C_{in} = \frac{1}{2\pi R_{in} f} \tag{14}$$

$$= \frac{1}{2\pi \times 20000 \times 1.69} = 4.7 \mu F$$

The connection on the circuit will be as shown in the following figure.

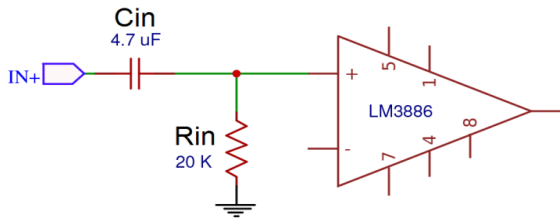

Figure 19. Low cutoff frequency circuit.

Another high pass filter will be connected as a feedback loop, containing a resistor R_i and a capacitor C_i . The capacitor here affects the bass response. The value of C_i is calculated using the formula:

$$C_i \geq \frac{\sqrt{2} \times (R_{in} + R_b) \times C_{in}}{R_i} \tag{15}$$

$$C_i \geq \frac{\sqrt{2} \times (20000 + 1000) \times 0.0000047}{1000}$$

Therefore, C_i should be greater than 140 μF , and we will choose a 470 μF capacitor, as shown in the following figure.

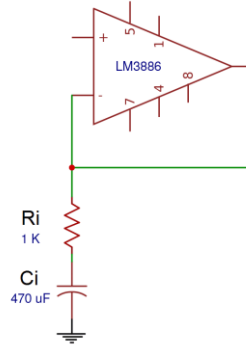

Figure 20: Low cutoff frequency at the feedback loop.

A low pass filter will be formed by the resistor R_b and the capacitor C_c to set the input's highest frequency. A 680 pF capacitor will give us a cutoff frequency of 234 kHz, based on the following equation:

$$C_c = \frac{1}{2\pi R_b F_c} \tag{16}$$

$$= \frac{1}{2\pi \times 1000 \times 234000} = 680 pF$$

The following figure shows the low pass filter at the input of the circuit.

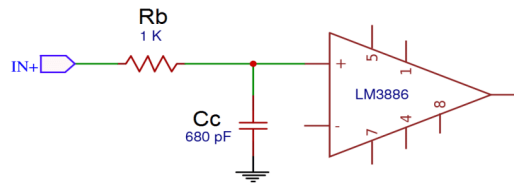

Figure 21. Low pass filter at the audio input.

To improve the stability and reduce the feedback loop's resonance, we add a resistor R_{f2} and a capacitor C_f parallel with R_f . These three components form a low pass filter for a specific cutoff frequency. We calculate the value of C_f using the following formula:

$$F_c = \frac{R_f \times R_{f2} (s + \frac{1}{R_{f2} \times C_f})}{(R_{f1} + R_{f2}) (s + \frac{1}{C_f (R_{f1} + R_{f2})})} \quad (17)$$

The optimum value of C_f calculated is **50pF**, as shown in the following circuit.

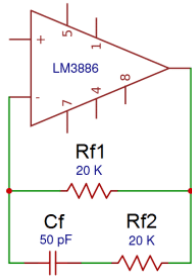

Figure 22: Stability components Rf2 and Cf.

The inductive loads cause some oscillations. To prevent them, we use the Zobel network. It helps restrain the radio frequencies picked up by the speaker's wires to go back to the amplifier circuit. The capacitor C_{sn} is very low, so at high frequency, the current goes to the ground. We chose two values for the resistor and the capacitor where $R_{sn}=4.7 \text{ Ohm}$, **1W**, and $C_{sn}=220\text{nF}$.

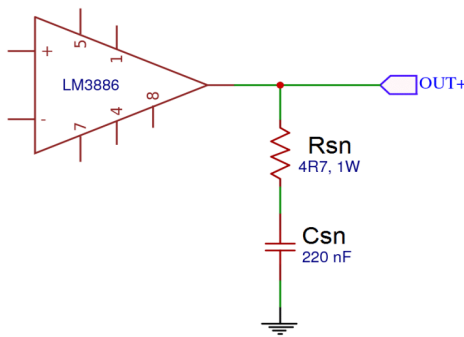

Figure 23: Zobel Network.

A resistor represents the Thiele network in parallel with an inductor at the output of the circuit. This network reduces the oscillations caused by the capacitive loads and reduces the radio frequency caused by the speaker's wires to get back to the amplifier circuit. The datasheet of LM3886 recommends a resistor of **10 Ohm, 5W**, and an inductor of **0.7μH**.

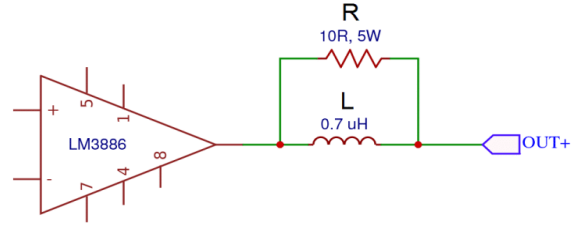

Figure 24: Thiele Network.

Decoupling capacitors are connected in parallel in the negative and the positive supply. The large capacitors provide a durable source of current when a low frequency takes place at the output. The optimal values for a bass frequency are between **470μF** and **2200μF**.

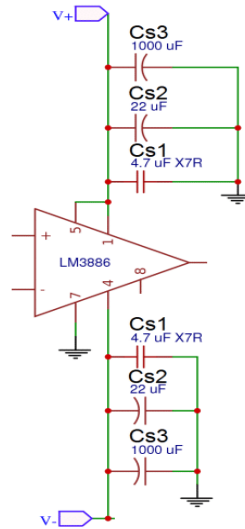

Figure 25. Power supply decoupling capacitors circuit.

After calculating and designing each component's values, the amplifier's circuit is ready to be tested on the Proteus software, and then a PCB layout is designed.

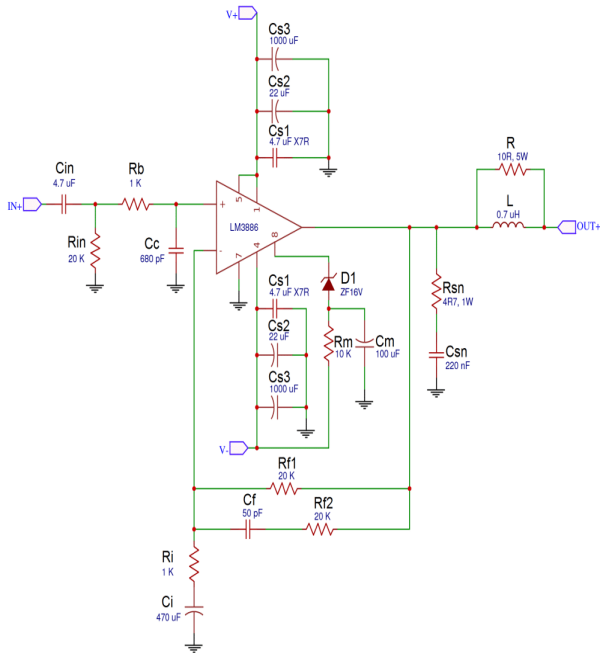

Figure 26: The final schematic of the amplifier circuit.

VI. SIMULATION AND RESULTS

The Sound wave fire extinguisher is a device that allows the suppression of fire with no water, chemical agents, halons, or gases. The device comprises a frequency generator that generates a signal with a low frequency between 30 Hz and 60 Hz. This signal enters into an amplifier that increases its amplitude and gives it the ability to be an audio signal produced by a subwoofer.

Once the coil's movement vibrates the speaker's diaphragm, it produces sound waves traveling in the air particles. The air movement occurs inside a tube called "vortex cannon," where the air molecules pass through the vortex nozzle at high speed, making rings shape of air. Thus, when the device is placed facing a fire, the oxygen molecules will be dispersed, putting out the flame.

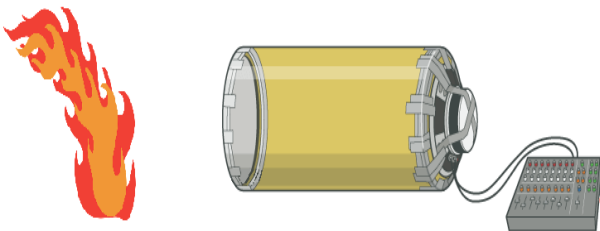

Figure 27: Full System Components

Working on a portable fire extinguisher prototype needs some experiments and simulations. The amplifier and the frequency generator circuits are simulated on the Proteus software to analyze the results before working on the hardware part. This chapter will present the simulations' results and the sound wave extinguisher's effect on the fire.

The amplification part of the project is the most important since the signal's amplitude will affect the speaker's voice coil's movement. The more the signal is amplified, the more the speaker's diaphragm will move up and down, making a powerful sound wave that moves the particles in the air. In our project, the amplifier must keep the signal pure without any noise and harmonics. As explained in the design part, some components in the amplifier will achieve this goal. The following figures show the amplifier circuit's simulation and how the sine or the square signals are amplified.

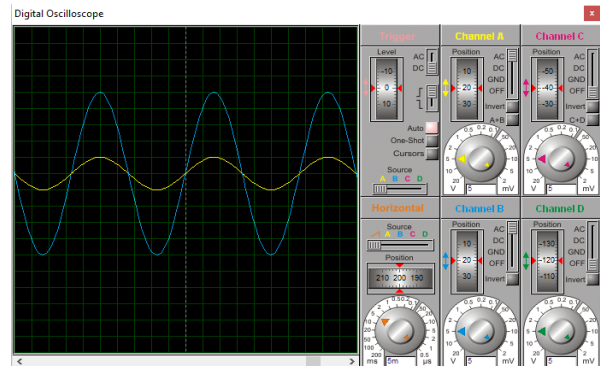

Figure 28: Sine wave amplification

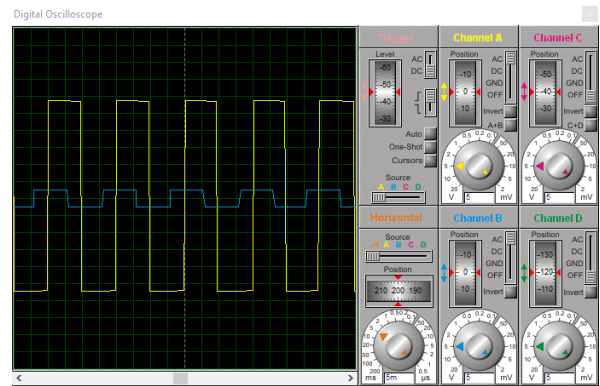

Figure 29: Square wave amplification.

The frequency generator is the portable fire extinguisher that generates the signal to the amplifier with a specific frequency. Our prototype was very important to implement a frequency generator with a wide range to test how the flame can be suppressed. Using the ATmega328 microcontroller, a rotary encoder, and an LCD screen, the

user can change the type of the signal (square, sine, sawtooth, triangular) and the frequency of the wave.

The frequency generator circuit was implemented first on the Proteus software before printing it on a PCB. The following figure shows the result of the virtual oscilloscope.

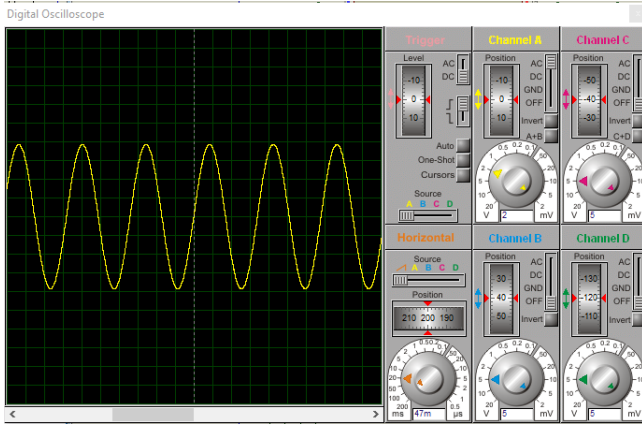

Figure 30: Sine wave using the frequency generator circuit.

The frequency generator circuit is printed on a PCB, and it was tested on an oscilloscope. The following figures show the frequency generator and the sine wave generated.



Figure 31: Frequency generator on PCB.

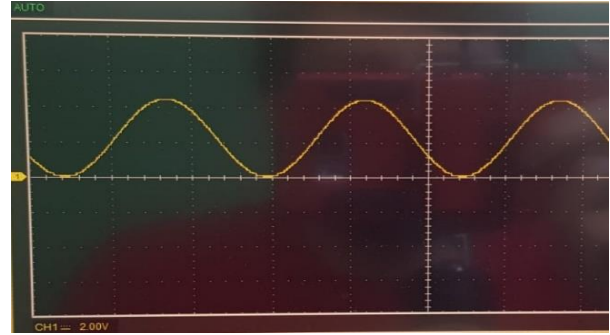

Figure 32: Sine wave generated by the frequency generator circuit.

Several tests were done on different speakers and frequencies to find the speaker's optimal type of signal, frequency, and power. In the first experiment, a 60 Watt speaker is used in front of a candle flame, and the flame was suppressed after 1 second at a maximum distance of 5 cm from the speaker. A 180 Watt subwoofer replaced the speaker, and the flame was suppressed in less than 100 milliseconds at a maximum distance of 12 cm. When a 400 Watt speaker was used, connected to vortex cannon, the flame was suppressed in less than 100 milliseconds at a distance of 40 cm, as shown in the following figure.



Figure 33. Flame suppression using the 400-watt speaker.

After many tests using a frequency generator, it was found that the type and the frequency of the signal are related to each other. All types of signals can be used in fire suppression, but the sine wave is preferred since it helps the speaker's voice coil move softly without damaging the diaphragm. However, after the experiment using a square wave with a frequency of 30 Hz had the same effect on the fire when a sine wave is used with a frequency of 50 Hz. Moreover, the best choice to suppress the fire is a sine wave with a 30 Hz frequency. After all the experiments, a final prototype is tested on fire with a continuous source of gas. The fire takes about 3 seconds to be suppressed at a distance of 20 cm from the extinguisher.

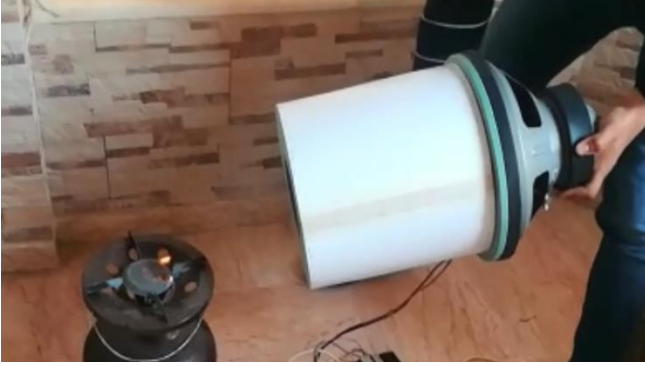

Figure 34. The final prototype of the portable fire extinguisher.

VII. CONCLUSION

After all the experiments done on the portable sound wave fire extinguisher and comparing it to the traditional fire extinguishers, we figured that firefighting using sound waves is impossible or a hopeless device. It has many pros and cons. The main problems that we faced are:

- The portable fire extinguisher must very close to the fire to suppress it. The maximum distance that we reached was 40cm using a 400-watt speaker. If we want to reach a longer distance, we need to use a 1500 or 2000 Watt speaker, which will make the device more expensive.
- The sound wave direction should be directed towards the flame, so if this device were fixed in a room, it would be effective only if the fire occurs in front of it.
- The sound wave fire extinguisher costs more than the traditional fire extinguishers.

With the help of dromes or robots, sound wave firefighting techniques avoid contact between humans and fires. It can also be used side by side with the traditional extinguishing agents to increase efficiency and extinguish the fire in a shorter time. In space, sound wave fire extinguishing is very efficient to avoid chemical agents in spaceships. Kitchen, hospitals, malls, and the industry sector may get benefit from this project. Moreover, the most important, in the electrical sector, sound wave fire extinguishing could be a fire system used in electrical panels. Avoiding the damage of the components in a panel due to the traditional extinguishing agents, the sound wave is a clean method, nontoxic, with no expiration date, and less damage to surroundings. Sound wave extinguisher leaves no residue compared to other extinguishing techniques, and it has a lighter weight. Firefighting with sound waves has a promising future. The past results motivate us to work on a

project that can extinguish a huge fire, save the world, our planet, and all living beings.

REFERENCES

- [1] ESFi, 2 April 2015. [Online]. Available: <https://www.esfi.org/resource/home-electrical-fires-184>. Accessed 25 December 2019.
- [2] A. M. P. Helmenstine, Is Fire a Gas, Liquid, or Solid?, ThoughtCo, 14 October 2019. [Online]. Available: <https://www.thoughtco.com/what-state-of-matter-is-fire-604300>. Accessed 30 December 2019.
- [3] E. Inglis-Arkell, How does fire behave in zero gravity? GZMODO, 03 August 2011. [Online]. Available: <https://io9.gizmodo.com/how-does-fire-behave-in-zero-gravity-5779127>. Accessed 22 December 2019.
- [4] Marsden Fire Safety, Fire safety services, [Online]. Available: <https://www.marsden-fire-safety.co.uk/resources/fire-extinguishers>.
- [5] J. C. Voelkert, "Fire and Fire Extinguishment, A brief guide to fire chemistry and extinguishment theory for fire equipment service technicians, 2009.
- [6] M. Rouse, Sound Wave, Whatis, September 2005. [Online]. Available: <https://whatis.techtarget.com/definition/sound-wave>. Accessed 22 December 2019.
- [7] S. Goyal, Jagranjosh, 7 May 2018. [Online]. Available: <https://www.jagranjosh.com/general-knowledge/what-are-the-characteristics-of-sound-waves-1525678871-1>. Accessed 20 December 2019.
- [8] Discovery of Sound in the Sea, dosits, [Online]. Available: <https://dosits.org/science/sound/characterize-sounds/intensity/>.
- [9] J. Segeborn, How does a speaker work? <https://www.youtube.com/user/JohanSegeborn>, 2014.
- [10] L. Sebastian, Subwoofers, Woofers, and Tweeters as Fast As Possible, Techquiekie Youtube, 2014.
- [11] Akio, How does an audio amplifier work? Akio TV Youtube.
- [12] Electronics Tutorials, [Online]. Available: https://www.electronicstutorials.ws/amplifier/amp_1.html. Accessed 31 December 2019.
- [13] S. Gupta, Classes of Power Amplifier, Circuit Digest, 11 December 2018. [Online]. Available: <https://circuitdigest.com/tutorial/classes-of-power-amplifier-explained>. Accessed 31 December 2019.
- [14] Firefighting Robot TAF35, EmiControls, [Online]. Available: <https://www.emicontrols.com/en/fire-fighting/mobile-fire-protection/firefighting-robot-taf35>
- [15] Ramesh Nayak. B, Bheemsha, Pundarika. G, "Performance Evaluation of Thermoacoustic Refrigerator Using Air as Working Medium" SSRG International Journal of Thermal Engineering 1.2 (2015): 16-21.
- [16] P. B. Varvadiya, P. D. Patel, A. McEwan, "Measurement of the Speed of Sound in Air Medium using Lissajous Patterns" SSRG International Journal of Electrical and Electronics Engineering 1.1 (2015): 5-8 .