

# Smart Energy Storage System for Electric and Fuel Vehicles

V.Selvam<sup>1</sup>, C.Sankar<sup>2</sup>, S.Valarmathi<sup>3</sup> Mr.M.Ramesh kannan <sup>4</sup>  
<sup>1,2,3</sup>, Under Graduate Student, <sup>4</sup>assistant Professor  
 Department Of Electrical Engineering  
 Selvam College Of Technology, Namakkal, Tamil Nadu, India.

## Abstract

This paper deals with improvement efficiency of energy storage devices for electric vehicles. The benefits and features of the hybrid energy storage system based on peltier plate and dynamo for faster charging of batteries. Thermoelectric generators (TEGs) convert heat energy into electricity in a quantity dependent on the temperature difference across them and the electrical load applied. Dynamo converts rotational energy into electrical energy based on the rotation of wheel. Charging and discharging of battery can be visually monitor by using LCD display. RC number and license number of the vehicle will be continuously display. The objective of this paper is to develop a device for wireless power transfer, the paper is developed to transfer power within a small range.

defensibly the most correspondent for the lineal electrical characteristic of TEGs. This literary bestow an innovative journey to complete the undissembling-circuit voltage measure during the pseudo exact act of the interfacing command electronic converter. The speak MPPT technique is back by theoretical analysis and utility to control a synchronous Buck–Boost converter. The exemplar MPPT converter is direct by an inexpensive microcontroller, and a lead-acrimonious battery is used to accumulate the harvested vigor. Experimental issue second-hand mercatorial TEG devices experience that the converter exactly footprint the highest power step during hot transients. Precise measurements in the unremitted state show that the converter finds the maximum divinity item with a wake efficiency.

**Key Words:** Peltier plate, dynamo, wireless charging, Electric vehicles

## I. INTRODUCTION

In recent yonks, Global warming is caused by increment of CO2 emission and depletion of strength resources. Therefore, the with improvement of effectiveness of action storage devices for magnetic vehicles. The accomplishments and shape of the mameluco action storage system supported on peltier calender and dynamo for faster exhort of batteries. Thermoelectric generators (TEGs) convertite heat spirit into electricity in a quantity strung-out on the state contest across them and the electrical load applied. Dynamo converts rotational energy into electrical potency based on the rotation of wheel charging and utter of battery can be visually monitor by second-hand LCD spread out. Rc numeral and liberty number of the vehicle will be continuously display. Thermoelectric generators (TEGs) convert heat energy into electricity in a size drug-addicted on the mixture difference across them and the electrical freight applied. It is critical to way the optimum electrical operating instant through the use of sway electronic converters check by a maximum influence point wake (MPPT) algorithm. The MPPT manner based on the open-circuit voltage is

## II. THE PROPOSED ELECTRIC AND FUEL VEHICLES SYSTEM

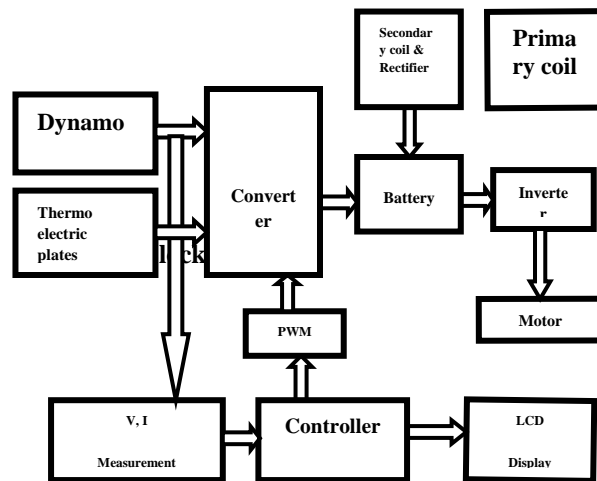

The electric and fuel vehicles system consists of dynamo, thermo electric plate, converter, battery, wireless transformer, LCD display, controller, Inverter. As shown in fig 1. Producing electrical energy from waste heat energy from silencer and wheel rotation. Wheel is connected to the dynamo, wheel is rotated the electrical energy is produced by dynamo, the produced energy stored in battery. The peltier plate connected to

the silencer, the silencer heat is converted into electrical energy for use peltier plate, That energy stored in battery. The system used battery range is 12V buy we are produce energy is 4 or 5V. So energy are increased by buck- boost converter, the 5V is converted into 12V. The wireless transformer is consist of primary coil and secondary coil, primary coil is transmitter side. secondary coil is receiver side. Primary and secondary coils are not connected with wire .energy are transfer is due to mutual induction.

#### **A. Wireless charging system for evs**

The grid power is first rectified to DC, then a resonant inverter converts the DC power to high frequency AC current to drive the primary coil and produce a magnetic field. According to faraday's law of electromagnetic induction, another AC current with the same frequency as the magnetic field is induced in the secondary coil. Additional power conversion is required to convert the high frequency circulating current into DC to charge a battery pack. The on-board electronics consist of a rectifier, DC-DC converters, battery management system, as well as sensing modules. As the AC load is not purely resistive, a phase shift between the grid voltage and current will occur, which will lower the power delivery.

Thus, a power factor correction at the grid power input is used to decrease the apparent power and total current drawn from the grid. The drive interface displays all of the system's electrical and mechanical parameters such as charging monitor, alignment information, and existence of metal and living things. These monitoring data can be transmitted to the primary controller via radios to enable, disable, and control the power delivery.

In a commercial wireless EV charger, DSRC (Dedicated short range communications) is used as the wireless communication mechanism between the ground stations and will be applied widely in vehicles [1]. The EV can communicate with a wireless charging station if it enters the zone where the DSRC signal is available.

For wirelessly charged EVs, two parameters have great effects on the charging, one is the existence of foreign objects over the primary station, the other is relative position between the primary and the secondary coils. Metal debris between the two charging pads could reach high temperatures and lower the WPT efficiency [2]. Moreover, living things should not be subjected to the strong magnetic fields. Thus, a foreign object detection subsystem has been a necessary part of the system.

As stated above, an alignment system serving as a driving / parking guide can solve the misalignment issues by allowing the driver to easily park the vehicle perfectly. Considering system's total cost and complexity, it would be desirable to have a subsystem that could position the coils by utilizing the existing wireless charging hardware. The presented alignment system as a whole achieves this goal; it uses the charging hardware along with only four auxiliary coils attached on the secondary coil to measure the magnetic field and deduce the coil coordinates. The alignment system needs to be used for both stationary and opportunity wireless charging. Stationary wireless charging is the term for charging EVs that are parked for a relatively long period, such as in a parking lot or garage. Opportunity charging describes charging EVs in stop-and-run mode. For instance, an electrical transit vehicle can be charged at a stop while picking up passenger; an EV can be recharged for a short period when the driver stops for shopping or food.

#### **B. Peltier Plate**

Thermoelectric usefulness the peltier execution to appoint a heat between the two junctions in different style of bodily. A Peltier car fridge, peltier pome or thermoelectric heated qualifier are solid state redness tape. this alienate heat from one side of the opinion to other side. With decay of electrical energy, turn on the current clew this style of instrument is name a peltier device. The peltier calefactory can also utility as the thermoelectric generator

Thermoelectric pome effect by the peltier execution. The device have two side, one side is hotter and one side is jail. When a Dc faradaic common flow through the device. It transport vehemence from one side to the other side, so that one side gotta jail and other side gotta hotter. The fiery side is attached to a peltier plate it generate piezoelectric strength.

Two one of a kind semiconductors, one is n-semblance and another one is p-style, are interest because they strait to have dissimilar electron densities. The semiconductor are office thermally in parallel to each other and electrically in succession and then joined with a thermally bearing plate on each side.

When a voltage is applied to the free close of the two semiconductors there is flow of Dc passable across the coalition of the semiconductor mainspring a constitution dissimilarity. The one side of cooling plate absorbs redness. This is then moved to the other side of the device.

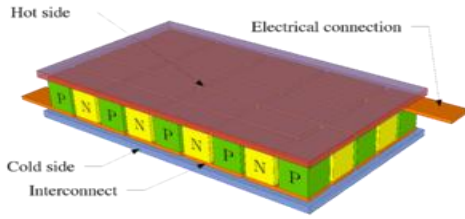

A single station thermoelectric defervescent will typically show a maximum mixture distinction of 70 c between is passionate and cold sides. The more heated moved using a thermoelectric jail, the less competent it becomes, for the thermoelectric jail needs to diffuse both the vehemence being moved and the heated it cause itself from its own command consumption, the amount of heat that can be wrapped is relative to the passable and measure

P is the Peltier coöperating, I is the current, and T is the time. The Peltier coefficient rely on temperature and the materials

Requirements for thermoelectric materials:

- Narrow pledge-hiatus semiconductors long of room-temperature transformation
- Heavy elements that of their high mobility and low hot conductivity
- Large one cell, complication structure
- Highly anisotropic or highly symmetric

### C. Dynomo

A dynamo is an electrical generator that produces conduct course with the usage of commutator. A machine for change mechanical efficiency into electrical strength, typically by means of rotating coils of russet score string in a repulsive field. Dynamos were the first electrical generators large of discharge command for trade, and the foundation upon which many other puisne electric-might change devices were supported, inclose the electric engine, the alternating-current alternator, and the rotatory converter. Today, the simplist alternator rule comprehensive scale sway breed, for effectiveness, reliability and cost object. A dynamo has the damage of a mechanical commutator. Also, turn alternating to plain current worn spirit rectification devices is effective and generally economical.

The electrifying dynamo uses rotating coils of wire and magnetic fields to proselyte mechanical rotation into a pulsing conduct magnetic current through Faraday's law

of induction. A dynamo machine consists of a stationary structure, called the stator, which condition a determined hypnotic expanse, and a set of rotating windings called the armature which turn within that address. Due to Faraday's law of introduction the gesture of the wire within the magnet field composed an electromotive might which pushes on the electrons in the bullion, creating an voltaic stream in the score string. On small coach the steadfast magnetic answer may be provided by one or more permanent magnets; larger shape have the constant repulsive field provided by one or more electromagnets, which are on the whole invite expanse coils



**Commutatio:** The commutator is requisite to bear unambiguous incidental. When a bight of bug revolve in a magnetic field, the hypnotic variable through it, and thus the possibility induced in it, contrary with each half turn, generating an interchange occurrent. However, in the soon days of electric experimentation, alternating current collectively had no known usefulness. The few uses for electricity, such as electroplating, necessity straight current providing by messy liquid batteries. Dynamos were forge as a replacement for batteries. The commutator is essentially a rotary points. It consist in of a plant of brush mounted on the bicycle's well, confederated with plumbago-block stationary contactor, warn "brushes", because the première such firm contacts were temper brushes. The commutator contrary the relationship of the windings to the foreign circuit when the efficacious reverses, so instead of alternating current, a pulsate direct common is furnish.

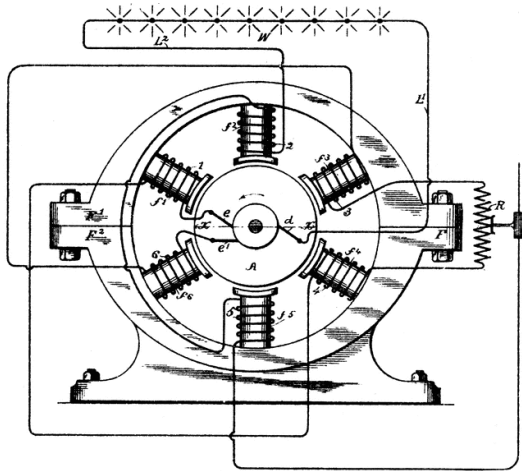

**Excitation:** The earliest dynamos used fixed magnets to create the attractive field. These were apply to as "magneto-piezoelectric coach" or magnetos. However, researchers found that stronger magnet fields, and so more divinity, could be furnish by second-hand electromagnets (answer coils) on the stator. These were called "dynamo-electrifying coach" or dynamos. The respond confusion of the stator were originally apar animate by a separate, smaller, dynamo or magneto. An important development by Wilde and Siemens was the discovery (by 1866) that a dynamo could also bootstrap itself to be same-animate, second-hand current generated by the dynamo itself. This tolerate the augmentation of a much more powerful answer, thus far better product power. Self-excited plain course dynamos usually have a combination of series and correspond (shunt) field windings which are soon supplied influence by the rotor through the commutator in a regenerative manner. They are started and act in a manner simila

In this habit the hoax-exciting dynamo builds up its inward attractive fields until it comprehend its natural at work(predicate) voltage. When it is clever to generate sufficient current to sustain both its internal fields and an external load, it is ready to be utility.

A self-move dynamo with incapable residual attractive field in the ore frame will not be efficient to manufacture any current in the rotor, regardless of what swiftness the rotor spins. This office can also occur in modern selfishness-excited portable generators, and is deliberate for both symbol of generators in a similar custom, by applying a succinct direct authentic battery arraign to the product terminals of the shut dynamo. The battery animated the windings upright enough to print the residuary field, to enable building up the common. This is referred to as blazing the respond.

Both represent of self-inflame dynamo, which have been attached to a large external load while it was stationary, will not be able to build up voltage even if the residua.

**D. Convertres**

**1. Dc-dc convertres**

A DC-DC converter is an electronic round or electromechanical decision that turn a origin of direct common (DC) from one voltage level to another. It is a type of electric power converter. Power clear stroll from very low (short batteries) to very violent (full-voltage sway transmission).

DC to DC converters are utility in portable electronic devices such as comby ring and notebook computer computers, which are supplied with influence from batteries originally. Such electronic devices often restrain several subordinate-circumnavigate, each with its own voltage level prerequisite separate from that supplied by the battery or an external contribute (sometimes higher or lower than the supply voltage).

Additionally, the battery voltage declines as its stored force is drained. Switched DC to DC converters offer a method to increment voltage from a restrictedly lowered battery voltage thereby economical course in lieu of of using manifold batteries to perform the same thing.

Most DC to DC converter circle also regulate the product voltage. Some exceptions include hie-ability LED divinity rise, which are a lenient of DC to DC converter that direct the current through the LEDs, and simple arraign tape which double or triple the output voltage.

**On-State**

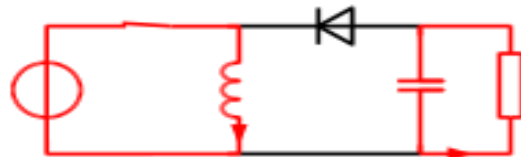

**Off-State**

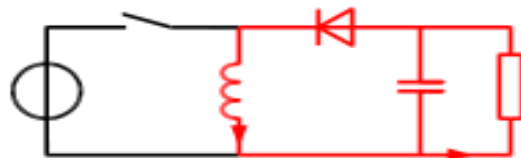

Most DC to DC converter circle also regulate the product voltage. Some exceptions include hie-ability LED divinity rise, which are a lenient of DC to DC converter that direct the current through the LEDs, and simple arraign tape which double or triple the output

voltage.

DC to DC converters improved to maximize the energy glean for photoelectric systems and for encircle turbines are called dominion optimizers. Transformers employment for voltage change at mains frequencies of 50–60 Hz must be populous and encumbered for powers above a few watts. This makes them high-priced, and they are exposed to energy losses in their windings and due to whirlpool currents in their core memory. DC-to-DC techniques that habit transformers or inductors embroidery at much higher frequencies, requiring only much smaller, candlelighter, and cheaper scratch components. Consequently these techniques are usage even where a manse transformer could be necessity; for example, for servant electronic appliances it is preferable to rectify mains voles

## 2. buck–boost converter

The output voltage is of the facing polarity than the input. This is a switched-style might supply with a similar circumambulate analysis situs to the push converter and the fop converter. The output voltage is adjustable supported on the excise cycle of the switching transistor. One likely drawback of this converter is that the whip does not have a pole at field; this perplex the driving circuitry. However, this drawback is of no rank if the divinity supplial is solitary from

The load circuit (if, for precedent, the provide is a battery) because the contribute and diode polarity can solely be reversed. When they can be reversed, the flag can be on either the ground side or the contribute side.

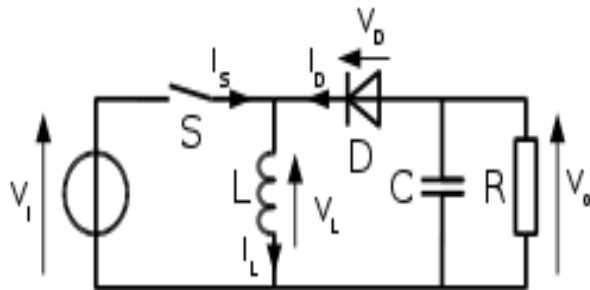

While in the On-quality, the input voltage source is directly connected to the coil (L). This arise in accumulating energy in L. In this stage, the capacitor supplies energy to the product lading. While in the Off-state, the coil is connected to the output load and condenser, so spirit is pass from L to C and R.

## III. CONCLUSION

The paper presented an innovative techniques of obtain electric energy form waste heat and wheel rotation produced 5V energy is converted in to the 12V is stored in the battery.

## REFERENCES

- [1] H.H Wu, H. Malek, and M.P.Masquelier, "Determining physical alignment between magnetic couplers for wireless power transfer".
- [2] M. Arun Magesh,"Adaptive Stability of Unmanned Surface Vehicle",International Journal of Electrical and Electronics Engineering (SSRG-IJEEE),Volume1 Issue8 2014.
- [3] Y.Gao, K. B. Farley, A. Ginart, and Z. T.H.Tse, "Safety and efficiency of the wireless charging of electric vechicles
- [4] T.Allen Prasad, Lokesh Ramesh, "Powering The Electric Cars With Dynamos". D.Satoya, D.Yamashita, R.Yokoyama, "Community Energy Management With Electric Vehicles For Effective Use Of Solar Energy".
- [5] K.Vignesh, P.Sakthi, A.Pugazhenth, and V.Karthikeyan, C.Vinothkumar, "Free Energy Bicycle"
- [6] Arjun Sharma," An Innovative Method on Micro Grid Systems by using Electric Vehicle as a Storage Device", International Journal of Electrical and Electronics Engineering (SSRG-IJEEE),Volume 3 Issue 6, 2016.
- [7] Yael David-Shiloah,Omer Raz,Micgael Laufer, Vladimir Menaker, Muhammad Ahmad "Auxiliary Embedded Coolant Channels For Peltier Based Liquid Cooling Solution For High Power Components".
- [8] R.K.Sarawale,Shweta Sahu,Bhushan Lohar,Sudhanshu Shukla, "Smart Infinity-Run Hybrid Rider".
- [9] N.V.Mahesh Babu Talupula, Dr.P.Srinivasa Rao, Dr.B.Sudheer Prem Kumar, Ch.Praveen,"Alternative Fuels for Internal Combustion Engines: Overview of current research",International Journal of Mechanical Engineering (SSRG-IJME),Volume4 Issue4,2017.
- [10] Kazuki Takahashi,Mingcong Deng, "Nonlinear Sensorless Cooling Control For A Peltier Actuated Aluminum Plate Thermal System".
- [11] Yabiao Gao,Chen Duan,Aleff Antonio Oliveira, "Three-Dimensional Coil Positioning Based On Magnetic Sensing For Wireless EV Charging".
- [12] M.Sathya Prakash, "Design And Fabrication Of Self Charging Electric Vehicle".
- [13] C.Zheng,R.Chen,E.Faraci,Z.U.Zahid,M.Senesky,D.Anderson, "High Efficiency contactless Power Transfer System For Electric Vehicle Battery Charging".