

Study of FACTS Controllers and its Impact on Power Quality

Pulakesh Kumar Kalita¹, Dr. Satyajit Bhuyan²

¹ ME Scholar, ² Associate Professor & Electrical and Instrumentation Engineering Department & Assam Engineering College & Gauhati University
Guwahati, India

Abstract

for last couple of decades the demand for electrical power has increased manifold and as we have limited resources of power generation, it results into heavy loading of the transmission line which leads to stability, voltage sag/swell and reactive power issues. Application of FACTS controllers in a power system is a promising and more efficient way for transfer and control of a bulk amount of power. This paper focuses on voltage dependency on reactive power and control of the same for improvement in the power quality. A comparative analysis of steady-state power flow control of a power system transmission network using FACTS controllers namely SVC, STATCOM and TCSC are performed. The performance of these FACTS controllers in the control of power flow on given test bus system is analyzed. Voltage magnitude is compared for shunt connected controllers to analyze the efficiency. Reactance modeling and power injection modeling techniques are used to incorporate the FACTS controllers into Newton Raphson load flow algorithm. Numerical results on a benchmark 5 bus test system with incorporation of each of the FACTS controllers are presented

Keywords - Power Quality, Voltage control, Reactive Power, FACTS, SVC, STATCOM, TCSC

I. INTRODUCTION

With the introduction of the deregulatory electricity market, the utilities must ensure a reasonable quality of power supply with high reliability. In addition to effects of the deregulation and creation of today's electricity market, utilities have to supply increased loads; also composed of power electronic based equipment, to the customer. To meet these increased loads, utilities would like to strengthen the transmission system by building more interconnectors; however, this is restricted by economic and social issues. Again with the widespread use of power electronic and sophisticated equipment Power quality has assumed increasing importance. A power quality problem is any occurrence manifested in voltage, current, or frequency deviation that results in failure or misoperation of customer equipment [1]. This results

in economic impacts on utilities, their customer, and suppliers of load equipment. The increase in the loading of the transmission lines sometimes can lead to voltage collapse due to the shortage of reactive power delivered at the load centers. This is due to the increased consumption of the reactive power in the transmission network and the characteristics of the load. To maintain economic & secure operation of large interconnected systems the safe operating margin can be substantially reduced[2] by the introduction of fast dynamic control on reactive and active power through power electronic controllers, making the AC transmission network more flexible and reliable. For maximization of power transfer capabilities, compensation of FACTS Controllers (series and shunt types) is required. The voltage magnitudes in the buses are held close to their nominal values by compensation through FACTS Controllers and in addition, line currents and total systems losses are also reduced. In this context, sophisticated and versatile devices called FACTS Controllers are effectively used in adjusting the bus voltage magnitude thereby contributing to the improvement in voltage stability of the power system [3]. By making a change in the bus voltage amplitude, bus voltage angle and transmission line reactance with the help of FACTS Controllers, the flow of power can be controlled. STATCOM, SVC, TCSC, etc., are some of the FACTS Controllers which are used for mitigating power system network problems and improving the power quality. As the power supply can only control the quality of the voltage and has no control over the load-dependent current, hence the quality of voltage is considered to be equivalent to power quality [4].

II. POWER QUALITY(PQ): CAUSES AND ISSUES

A. Cause of deterioration in PQ

Under natural causes

- Faults or lightning strikes on transmission lines
- Falling of trees on distribution feeders
- Equipment failure

Under manmade causes

- Load or feeder/transmission line operation viz. transformer energization, capacitor or feeder switching

- PE loads such as ups, ASD, converters, arc furnaces and induction heating systems
- Switching of large loads [5]

B. Common PQ issues

Harmonics: Excessive losses and heating in motors, capacitors, and transformers connected to the system.

Flicker: Visual irritation, the introduction of many harmonic components in the supply power and their associated equipment.

Transients: Tripping, components failures, flashover of instrument insulation hardware booting, software glitches, poor product quality etc.

Voltage sags: Devices /process downtime, the effect on product quality, failure/malfunction of customer equipment and associated scrap cost, clean-up costs, maintenance and repair costs etc.

III. REACTIVE POWER

Reactive power is the latent soul of power transmission system. It is very precious in keeping the system voltage stable. It is generated when current waveform is not in phase with voltage waveform because of energy conserving elements like inductor or capacitors [6]. Components of current in phase with voltage generate active power that does the real work. Reactive power is required for producing magnetic and electric fields in inductors and capacitor respectively.

The voltage in the transmission line can be varied with a variation of reactive power. This can be illustrated as follows

- Q₁= Reactive power demand by the load
- Q₂= Reactive power supplied by source
- Q_R= Q₁-Q₂ (in receiving end)

$$Q_R = \frac{V_R V_S \cos \delta - V_R^2}{X_L} \tag{1}$$

Assuming $\delta \rightarrow 0$ or $\cos \delta \rightarrow 1$

$$Q_R = \frac{V_R V_S - V_R^2}{X_L} \tag{2}$$

On solving we get

$$V_R = \frac{V_S}{2} \pm \frac{\sqrt{V_S^2 - 4X_L Q_R}}{2} \tag{3}$$

Hence the change in reactive power causes required change in the receiving end voltage. With the help of various devices, the reactive power generation has been controlled. For maintaining economic and secure operation of a large interconnection system, fast dynamic control over reactive and active power by high power electronic controllers is introduced. This makes the system more reliable and flexible to adapt to changing conditions caused by contingencies and load variations. Reactive power compensation is considered as a powerful tool for optimizing the power flow on transmission networks. Who’s

inadequate supply or demand lead to voltage collapses and has been a major cause of several recent major power outages worldwide [7]

For a typical transmission line,

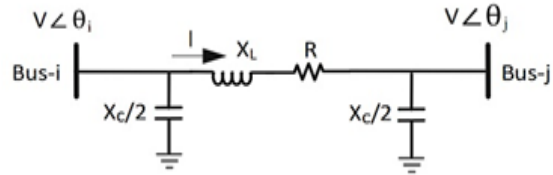

Fig.1 π-model single line diagram

The line capacitance supplies Q_{produced} reactive power and the line inductance consumes Q_{consumed} for an ideal line(R=0)

$$Q_{produced} = \frac{V^2}{X_C} \tag{4}$$

$$Q_{consumed} = I^2 X_L \tag{5}$$

- Where V =bus voltage
- X_C=line capacitance reactance
- X_L= line inductive reactance
- I =line current

At surge impedance loading

$$Q_{produced} = Q_{consumed}$$

Surge impedance

$$Z_0 = \frac{V}{I} = \sqrt{\frac{X_L}{X_C}} \tag{6}$$

and

$$SIL = \frac{V^2}{Z_0} \tag{7}$$

From above expression, we can say that an ideal line loaded at its surge impedance loading does not produce or consume reactive power, so it will have same voltage at both ends. Hence, the balance of both consumption and production of reactive power at a particular loading level result in a flat voltage profile along the line. Consumption of reactive power increases with the square of the current, thus we face difficulty to transport reactive power along long lines

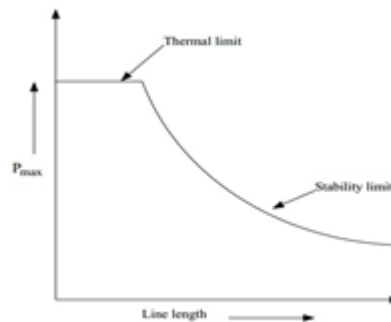

Fig.2 Power transfer capacity as a function of line length [2]

Reactive power flow can be controlled by Series and Shunt compensation devices. Conventionally switched shunt/series compensators and phase shifting

transformers have been utilized. Modern power electronic based devices are now used for reactive power compensation. These are categorized as FACTS controllers. Compensator’s application improves the power transfer capability. The power- δ curve below (fig. 3) shows the variation of power transfer with respect to power angle for various compensation methodologies, keeping compensation fixed at 50%.

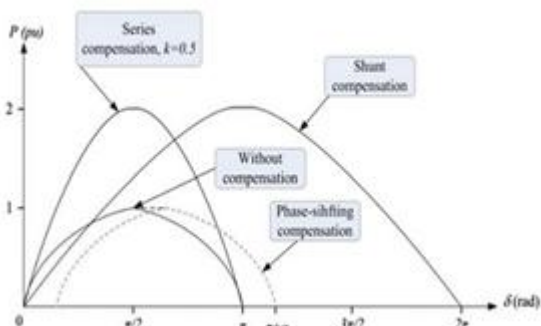

Fig. 3 P-δ curve

IV. FACTS

FACTS is defined as, “Alternating current transmission system incorporating power electronic based and other static controllers to enhance controllability and increase power transfer capability” [8][9]. The facts controllers are defined as "a power electronic based system and other static equipment that provides control of one or more AC transmission system parameters"[2].

Depending on PE devices used in control, the FACTS controllers can be classified as

- A) Variable Impedance
- B) VSC based

Variable impedance type controllers include

- i) SVC(static var compensators)(shunt connected)
- ii) A thyristor controlled series capacitor or compensator(TCSC)(series connected)
- iii) Thyristor controlled phase shift transformer(TCPST)

VSC based FACTS controllers

- i) Static synchronous compensator (STATCOM)(Shunt)
- ii) static synchronous series compensator (SSSC)(Series)
- iii) Interline Power flow controller(IPFC)(combined)
- iv) Unified Power flow controller(UPFC)(combined)

FACTS controllers are power electronic based devices which can change parameters like impedance, voltage, and phase angle, very rapidly and continuously. Therefore they have the ability to control reactive power flow pattern and enhance the usable capacity of the existing lines. FACTS devices are good to improve the power system efficiency, improve power factor and reduced in harmonics. A

comparison of few common FACTS controllers is provided in table 1 [12]

Sl. No	FACTS Device	Load Flow	Voltage control	Transient stability	Dynamic stability
1	SVC	Low	High	Low	Medium
2	STATCOM	Low	High	Medium	-do-
3	UPFC	High	High	Medium	-do-
4	TCSC	Medium	Low	High	-do-
5	SSSC	Low	High	Medium	-do-

Table 1

A. SVC(static var compensator)

Static var compensator systems are applied by utilities in transmission lines for several purposes. The primary purpose is usually for rapid control of voltage at weak points in the network. Installation may be at the midpoint of transmission interconnections or at the line ends. The location can be determined by the sensitivity of voltage at the critical buses with respect to the reactive power injection ($\Delta V_i/\Delta Q_j$). Static VAR compensator is shunt connected static generators/absorber whose outputs are varied so as to control voltage of electric power system. In its simple form, svc is connected as a fixed capacitor-thyristor controlled reactor (FCTCR) configuration-

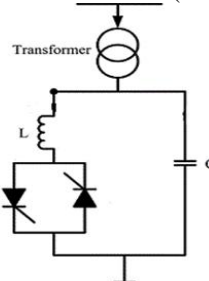

Fig. 4 SVC building block

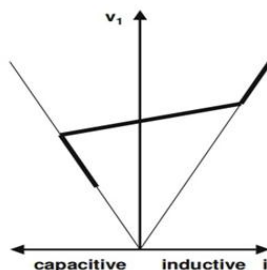

Fig. 5 SVC voltage/current characteristics

The SVC is connected to a coupling transformer that is a connected transformer that is connected directly to the ac bus whose voltage is to be regulated. The effective reactance of the FCTCR is varied by firing angle control, of the anti-parallel thyristor. The firing angle can be controlled through a PI controller

in such a way that the voltage of the bus, where the svc is connected is maintained at the reference value. The dynamic reactive control at the load bus increases power transfer and can solve the problem of voltage instability (collapse) caused by contingency conditions

B. STATCOM(static synchronous compensator)

STATCOM is a shunt connected static var compensator who’s capacitive or inductive output current can be controlled independently of the ac system voltage. Fig 6 shows a simple one-line diagram of statcom based on VSC.

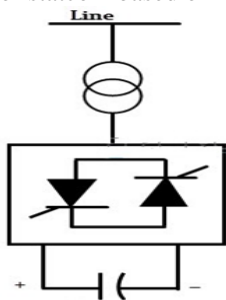

Fig. 6 STATCOM structure

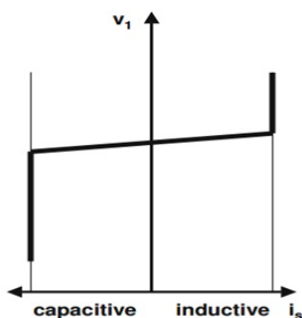

Fig. 7 STATCOM voltage/current characteristics

The voltage source converters convert dc voltage to a voltage by using GTO and the ac voltage is inserted into the line through the transformer. If the output of the VSC is more than the line voltage, converter output voltage then converter absorbs lagging vars from the source. STATCOM requires less space, has faster response and It can be interfaced with real power sources such as a battery, fuel cell or SMES (superconducting magnetic energy storage). Also, the reactive current can be maintained constant by STATCOM during low voltage condition.

C. TCSC(thyristor controlled series capacitor)

TCSC is series compensated FACTS device which consists of a series capacitor bank shunted by a thyristor controlled reactor in order to provide a smoothly variable series capacitive reactance. Fig 8 shows a single line diagram of a tcsc controller

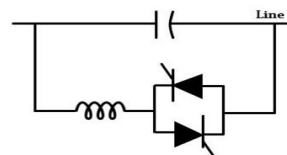

Fig. 8 TCSC structure

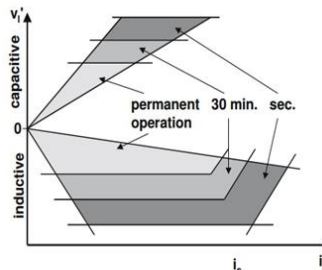

Fig. 9 TCSC operational diagram

The TCSC is based on thyristor without gate turnoff capability. In tcsc a variable thyristor controlled reactor is connected across a series capacitor when the firing angle of the TCR is 180°, the reactor becomes nonconducting and the series capacitor has the normal impedance. As the firing angle is decreased below 180°the capacitive reactance increases. When the firing angle is 90°, the reactor becomes fully conducting and total impedance becomes inductive. With the 90° firing angle, the tcsc helps in limiting fault current. It can be used to mitigate SSR. The TCSC was also labeled as RANI (Rapid Adjustment of Network Impedance) in a paper by Vithayathil et al [10]. In [11] technique is proposed for location.

V. MODELING

The IEEE 5-bus network is used to assess FACTS equipment capacities. It contains two generators each one has voltage and speed regulators. The buses are connected via seven tie lines of varying lengths. The lengths are calculated on the basis of the theory of traveling waves. This is explained later. The distributed parameters of transmission lines are in accordance with the frequency of generated AC by the generators. Three phase RLC series loads are connected to the load buses. The first bus is considered as the swing or slack bus. Each bus is equipped with load flow measuring blocks, which provides information about bus voltage magnitudes and respective angles. Transformers are connected wherever it is required in accordance with the theory of FACTS controllers. As the Powergui block is necessary for simulation of any Simulink model containing Simpower-systems blocks. It is used to store the equivalent Simulink circuit that represents the state-space equations of the model. We used the method of discretization of the electrical system for a solution at fixed time steps.

From the standard IEEE 5-bus system, the pu values for various line parameters are taken. The concept of

traveling waves is utilized for determination of line's electrical length

$$\beta l = \left(\frac{\pi}{180}\right)\theta \tag{8}$$

$$\left(\frac{2\pi f}{v_p}\right)l = \frac{\pi\theta}{180} \tag{9}$$

$$l = 13888.90m \tag{10}$$

With the help of above equation calculation of physical length is possible and implemented. The datasheet for standard 5 bus system is utilized for calculation of various parameters of the system.

Table 2

From bus	To bus	Resistance	Reactance	Capacitance	Susceptance
1	2	0.02	0.06	0	0.06
1	3	0.08	0.24	0	0.05
2	3	0.06	0.18	0	0.04
2	4	0.06	0.18	0	0.04
2	5	0.04	0.12	0	0.04
3	4	0.01	0.03	0	0.02
4	5	0.08	0.24	0	0.05

The base voltage chosen is 230KV and base power is 100MVA. The transmission line is in the range of short transmission line category; hence capacitance of line is neglected. The various facts devices are implemented in the bus system with requisite changes and modulation, and analysis is done by using a programmable voltage source. The comparison of power flow analysis on the 5bus test system is done without using FACTS controllers' viz. SVC, STATCOM, TCSC. However, for this 5-bus test system, only voltage magnitude was taken into consideration during the comparison. In all four cases, it is observed that the incorporation of FACTS controllers have improved the bus voltage profile and power flow of the whole network.

A. SVC implementation

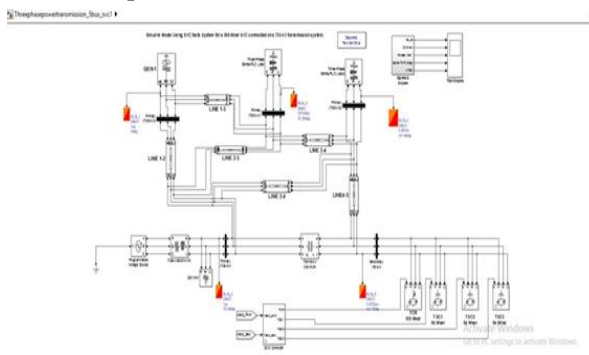

Fig.10

B. STATCOM implementation

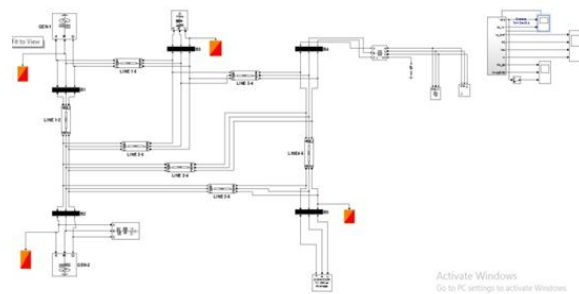

Fig. 11

C. TCSC implementation

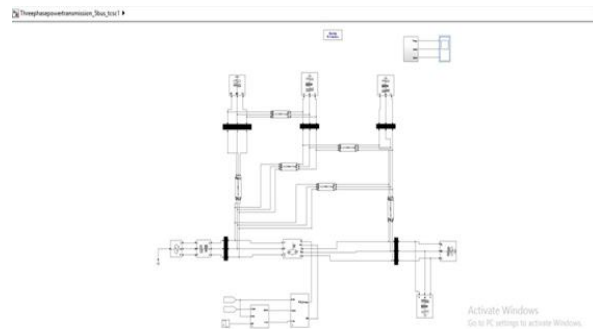

Fig. 12

VI. OUTPUT

SVC is shunt connected controller and it controls the voltage magnitude in the system. As the voltage magnitude falls the reactive power supply is provided by SVC to compensate the voltage magnitude. The reactive power flow is controlled by the thyristor valves present in the SVC module. (Fig. 13)

The output of STATCOM implemented bus system is much better than that of obtained by SVC. The controllability of STATCOM is better to SVC because of usage of modern power semiconductor switches. (Fig. 14)

The series connected FACTS controller TCSC helps in improving the power flow. Almost 250% increase in power flow can be seen by the output of scope. (Fig. 15)

As shunt compensators are primarily dealing with the voltage profile control, hence, a comparison of voltage magnitude is made in the 5-bus test system. In all the cases, it is observed that the incorporation of FACTS devices has improved the bus voltage profile and the power flow of the whole network. The figure (Fig. 16) below shows the bus voltage profile before and after incorporating FACTS devices into the test bus system. The voltage limit was set to be at 0.9pu and 1.1 pu. This is to ensure that voltage stability is achieved. From the figure, it can be seen that the voltage magnitude of the system without FACTS devices is lower than with the existence of FACTS device. Thus installation of FACTS device into low

voltage profile system has improved the overall voltage profile of the system. The voltage magnitude of bus 1 and bus 2 was not affected due to the presence of generator at the bus which makes it a PV

bus. From the figure, STATCOM is shown to possess the better able to improve the voltage profile as it was able to raise the overall voltage profile closer to 1.0pu as compared with test system with SVC model.

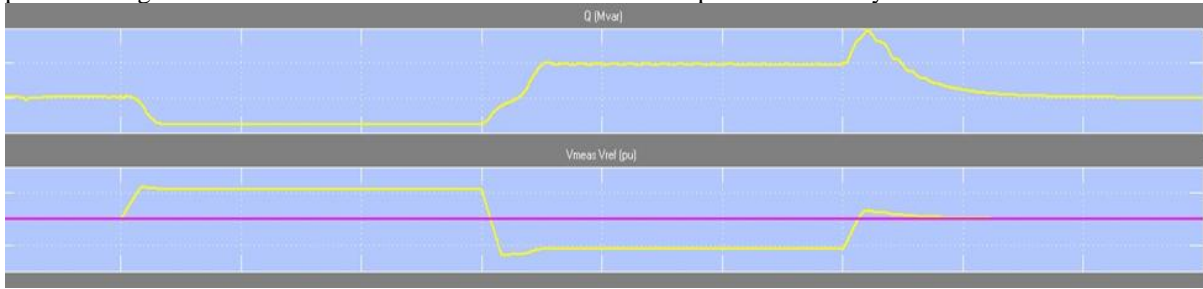

Figure 13

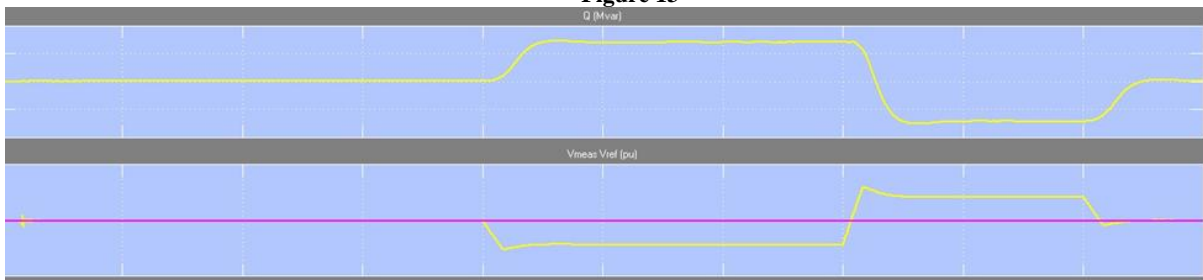

Fig 14

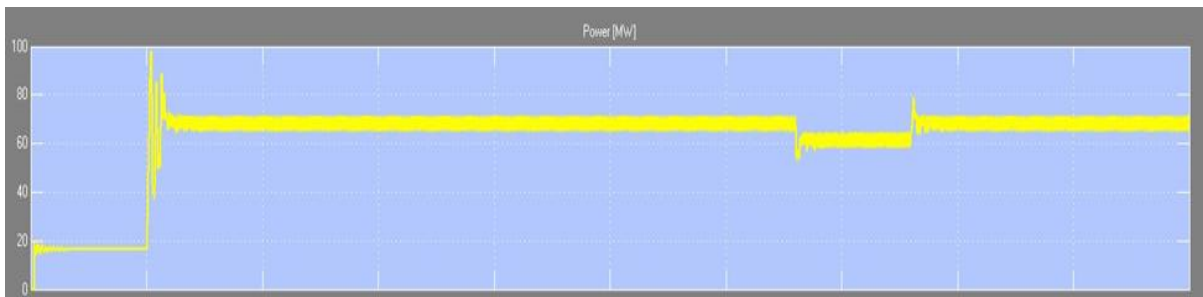

Fig 15

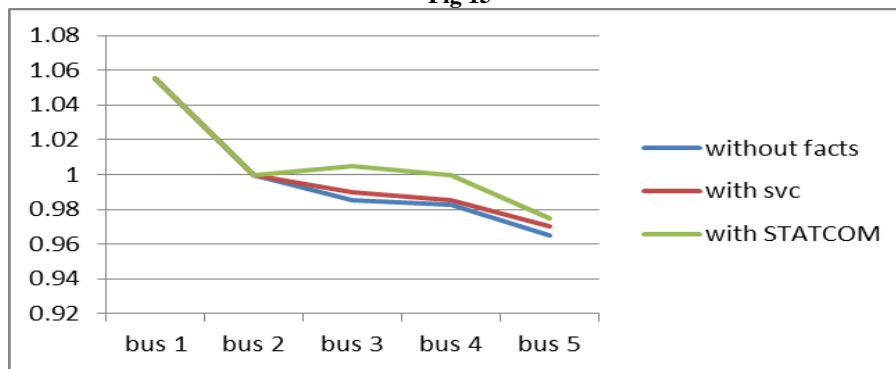

Fig 16

VII. CONCLUSIONS

In this paper, the performance of SVC, STATCOM, and TCSC in terms of voltage magnitude and power flow are compared. It is cleared that FACTS devices improve the power flow and voltage profile in the system in which they are connected. Shunt connected devices such as SVC and STATCOM improves the voltage of the bus in which it is connected and series devices TCSC improve the power flow. Also, STATCOM gives superior performance than SVC for

power measurement, bus voltage, rotor angle and terminal voltages of the multi-machine system. The FACTS controllers based on VSC have several advantages over the variable impedance type. A STATCOM is much more compatible and compact than an SVC for similar rating and is technically superior. It can supply required reactive current even at low values of the bus voltage and can be designed to have inbuilt short-term overload capability. Also, a STATCOM can supply active power if it has an

energy source or large energy storage at its DC terminals.

The only drawback with VSC based controllers is the requirement of using self-commutating power semiconductor devices such as GTO, IGBT etc. Thyristors do not have this capability and cannot be used although they are available in higher voltage rating and tend to be cheaper with reduced losses. With advancement in power, electronic technologies new and more versatile controllers have been developed. Devices with a higher degree of freedoms such as UPFC; proposed by Gyugyi[13], will get more focus as they are capable of controlling both voltage regulation and power flow in the system.

REFERENCES

- [1] R. Sastry Vedam, Mulukutla S. Sarma, "Power quality VAR compensation in power system", ISBN: 13: 978-1-4200-6480-3.
- [2] K.R.PADIYAR, "FACTS controllers in power transmission and distribution", new age international (p) limited publisher, ISBN (13): 978-81-224-2541-3
- [3] B.Viswanath, K. Revathi, T. R. Jyothsna, "FACTS Controllers for Enhancement of Power System Performance: State-of-the-art", International Journal of Pure and Applied Mathematics Volume 114 No. 8 2017, 265-273
- [4] Roger C.Dugan, Mark F.McGranaghram, Surya Santoso, H.Wayne Beaty, "Electrical power systems quality", third edition
- [5] Gerard Ledwich, Arindam Ghosh, "POWER QUALITY ENHANCEMENT USING CUSTOM POWER DEVICES" ISBN 978-1-4613-5418-5
- [6] N. Mahdavi Tabatabali, Ali Jafari Aghbolaghi, N. Bizon, Freek Blaabjerg, "Reactive power control in AC power systems"
- [7] R. Mathur, R. Varma, Thyristor-based FACTS controllers for electrical transmission systems, IEEE, 2002.
- [8] N.G.Hingorani , "Flexible AC transmission" IEEE Spectrum, v.30, n.u., pp.40-44,1993
- [9] N.G.Hingorani and L.gyugui, Understanding FACTS- Concepts and technology of flexible AC transmission systems, IEEE
- [10] J.Vithayathil, C. Taylor, M, Klinger and W. Mittelstadt, "Case Studies of Conventional and Novel Methods of Reactive Power Control on AC Transmission Systems", CIGRE, SC 38-02, 1988
- [11] Sujatha Subhash, B.N. Sarkar and K.R. Padiyar, "Sensitivity based determination of suitable locations for controlled series compensation for enhancement of steady-state stability in a large power system", IFAC Symposium on "Control of Power Systems and Power Plants", Beijing, August 1997.
- [12] Aishvarya Narain, S.K. Srivastava, "An overview of FACTS devices used for reactive power compensation Techniques", IJERT, vol 4, issue 12, December 2015.
- [13] L. Gyugyi, "A Unified Power Flow Controller concept for flexible AC transmission systems", IEE Proceedings-C, v. 139, n.4, 1992, pp. 323-331