

# Effective Optical Communication using Design of Delay Line Filter

A. Aasha<sup>1</sup>, S. Abirami<sup>1</sup>, M. Anitha<sup>1</sup>

<sup>1</sup>Department of Electronics and Communication Engineering  
NPR College of Engineering and Technology  
Natham, Dindigul, Tamil Nadu

**Abstract** - Various fiber-optic dispersion effects on optical transmission system are analyzed and dispersion compensation is done using Delay Line Filter (DLF). Delay line filter is implemented using X-coupler with single source, multiple source and filter. The optical transmission system consists of transmitter, an optical DLF for compensation, fiber transmission channel and a receiver. The performance of the filter is analyzed for single mode fiber using optisystem

**Keywords** – Delay Line Filter (DLF), Continuous Wave (CW), Non- Return-to-Zero (NRZ), Electro-absorption modulator (EAM), Pseudorandom Binary Sequence (PRBS).

## I. INTRODUCTION

In today's communication system there is a heavy demand for high speed communication. The high speed transmission can be easily achieved by optical fiber. The important problem in high bit rate communication is dispersion. Fiber dispersion reduces the performance of optical communication by broadening optical pulses during propagation inside the fiber. Fiber losses are also another limiting factor because they reduce the signal power arriving at the receiver [4]. For the accurate recovery of optical signal optical receiver need a certain amount of power, the transmission distance is limited by dispersion in the fiber. Dispersion is the phenomenon in which the phase velocity or group velocity of the wave depends on its frequency. Dispersion leads to the pulse broadening and distortion in the transferred bits. The dispersion is broadly classified as Intermodal dispersion and Intramodal dispersion. Intermodal dispersion occurs when the optical signal travel through different modes, experiences different delays which result in pulse broadening. Intramodal dispersion is a result of propagation delay difference between the different spectral components of the transmitted signal. There are various techniques are available for the dispersion compensation such as pre, post and mix compensation. There are various work

are already done in the analysis of pre, post, mix compensation techniques[4] and found that mix compensation gives better Q-factor and minimum BER on comparing to another techniques. Implementation of delay line filter shows that it will give effective Q-factor and minimum BER over mix compensation. Delay line filter is implemented using X-coupler with single source and multiple sources. It is also implemented with IIR filter. The Single Mode Fiber with positive dispersion 16ps/ns/km is analyzed for 50km. The Continuous Wave (CW) laser which operates at a frequency 193.1THz and power of 0dBm is used in Transmitter side.

The objective of this paper is to develop Optical Communication for error detection and error correction using SOA with Optisystem. The paper is organized as follows. In Section II, Filter Model is described. In section III, Delay Line filter layout is described. In Section IV Simulation results are presented. In section V, concludes the paper.

## II. FILTER DESIGN

Dispersion in the optical link can be compensated using the optical filter in fiber optical communication. Optical communication is a way of transmitting the information from one place to another by modulating the light signal with the information signal. Digital filter is a system that performs mathematical operation on a sampled, discrete-time signal to reduce or enhance certain condition of that signal [3]. Two types of digital filters are Recursive filter and non Recursive filters. Delay line recursive filter is analyzed here. These filters comprise unit delay, weight element and adders which are realized in optical domain. The input field is divided into N+1 different element which will be delayed separately by multiples of unit delays. Filter order can be determined by the highest delay. In the final stage the multiple copies of input field are recombined

The dispersion compensation technique with dispersion compensating fiber is analyzed. In post compensation technique the dispersion compensation fiber is placed next to the single mode fiber. When

the data from the modulator reaches the single mode fiber it experiences the negative dispersion and while it reaches the dispersion compensation fiber which already have positive dispersion get compensated

III. DELAY LINE FILTER LAYOUT

Transmitter system consist of the laser source, Non- Return-to-Zero (NRZ) wave form is generated from the binary values of pseudorandom binary sequence (PRBS) at length of 128, is provided to the Mach Zehnder modulator at a data rate of 10Gbps.

A. Delay line filter operation:

Step1: The first coupler X1 port in Fig. 2 is used for the incoming signal distortion by chromatic dispersion.

Step2: It is decomposed into two port component which depends on the coupling coefficient.

Step3: They are phase shifted before reaching the second coupler.

Step4: Summation operation of these components is performed in the second coupler

Step5: These summed components are once again split and time delayed and phase shifted.

Step6: Given to the third coupler, Y1 is used to receiving the compensated signal.

The Quality Factor and minimum Bit Error Rate for the filter design is analyzed using BER analyzer for the power of 0dBm. The Eye pattern for the simulation of delay line filter for single and multiple sources.

B. Electro-absorption modulator

Electro-absorption modulator (EAM) is a semiconductor device which can be used for modulating the intensity of a laser beam via an electric voltage. Its principle of operation is based on the Franz-Keldysh effect, i.e., a change in the absorption spectrum caused by an applied electric field, which changes the bandgap energy (thus the photon energy of an absorption edge) but usually does not involve the excitation of carriers by the electric field.

For modulators in telecommunications small size and modulation voltages are desired. The EAM is candidate for use in external modulation links in telecommunications. These modulators can be realized using either bulk semiconductor materials or materials with multiple quantum dots or wells.

IV.EXPERIMENTAL RESULTS

Optisystem 14 version has been used to implement a exiting and proposed layout, eye spectrum analyzer used to show error rate and Q factor values.Fig.1 shows existing Layout. Fig.2. and Fig.3. Shows Proposed layout and BER performance. Table.1. Summarize comparison chart.

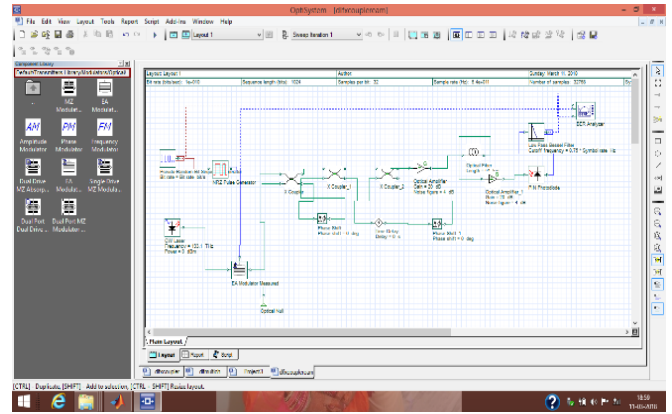

Fig.1. Existing Layout

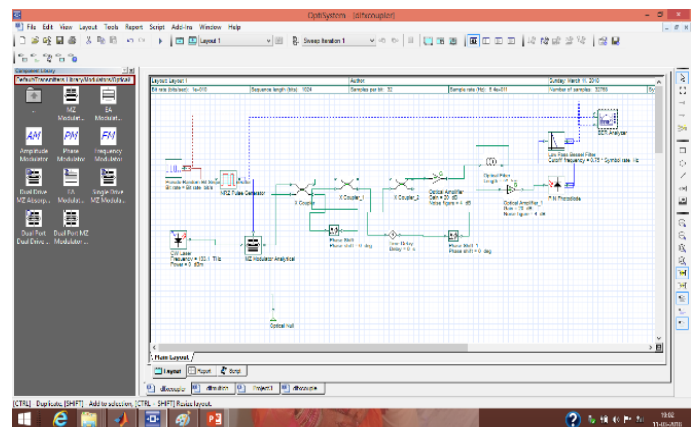

Fig.2. Proposed Layout

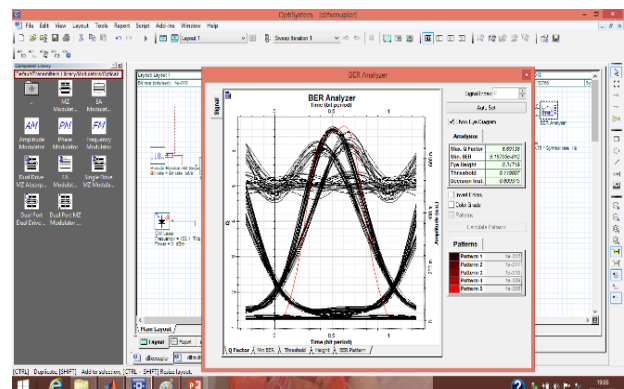

Fig.3. BER Performance

Table.I. Comparison chart

S.NO	PARAMETER	EXISTING	PROPOSED
1	Q Factor	6.6	7.4
2	Min BER	9.8E-12	2.4E-14

## VI. CONCLUSION

Communication channel with single mode fiber at the data rate of 10Gbps is investigated. On comparing the performance of the delay line filter using x-coupler and delay line IIR filter in the BER analyzer, it is found that the Q-Factor of 11.67 for delay line IIR filter is high and with the reduced BER of  $8.4e-032$ . This shows the better result on comparing with the existing method, the dispersion compensation using dispersion compensating fiber given in the delay line filter can give better performance on comparing with other technique.

## REFERENCES

- [1] A. Rahim, "Finite Impulse Response Filter Using 4-Port MMI Couplers for Residual Dispersion Compensation," *IEEE Journal of Lightwave Technology*, vol. 30, no. 7, pp. 990–996, April. 2012.
- [2] G.Aarthy, P.Prakash, M.GaneshMadhan "Design and Analysis of 4 Port Coupler based Delay Line Filter for Dispersion Compensation" *International Journal of Emerging Technology in Computer Science & Electronics (IJETCSE)* Volume 1, Issue 1, January 2013.
- [3] T. Duthel et al., "Quasi-analytic synthesis of non recursive optical delay line filters for reliable compensation of dispersion effects," *IEEE Journal of Lightwave Technology*, vol. 24, no. 11, pp. 4403–4410, November 2006.
- [4] Bo-ning Hu et al., "Analysis on Dispersion Compensation with DCF based on Optisystem," 2nd International Conference on Industrial and Information Systems, 2010.
- [5] Zhang Hongbin, Qiu Kun, "Emulation of characteristics of optical fiber transmission for a 10Gb/s single channel situation," *actaphotonica sinica*, vol.30, no.6, pp. 715-720, 2001.
- [6] M. Secondini, E. Forestieri, and G. Prati, "Adaptive minimum MSE controlled PLC optical equalizer for chromatic dispersion compensation," *IEEE Journal of Lightwave Technology*, vol. 21 no. 10, pp. 2322–2331, October 2003.
- [7] Q. Wang, T. Liu, and Y. C. Soh, "All-fiber Fourier filter flat-top interleaver design with specified performance parameters," *Journal of Optical Engineering*, vol. 42, no. 11, pp. 3172–3178, November 2003.
- [8] M. Bohn, W. Rosenkranz, and P. Krummrich, "Adaptive distortion compensation with integrated optical finite impulse response filters in high bit rate optical communication systems," *IEEE Journal of Selected Topics in Quantum Electronics*, vol. 10, no. 2, pp. 273–280, March/April 2004.
- [9] J D. Marom, C. Doerr, M. Cappuzzo, E.Y. Chen, A. Wong-Foy, L. Gomez, and S. Chandrasekhar, "Compact colorless tunable dispersion compensator with 1000-ps/nm tuning range for 40 Gb/s data rates," *IEEE Journal of Lightwave Technology*, vol. 24, no. 1, pp. 237–241, January 2006.
- [10] C. Doerr, S. Chandrasekhar, M. Cappuzzo, A. Wong-Foy, E. Chen, and L. Gomez, "Four-stage MachZehnder type tunable optical dispersion compensator with single knob control," *IEEE Photonics Technology Letters*, vol. 17, no. 12, pp. 2637–2639, December 2005.
- [11] L.Zimmermann, K.Voigt, G.WinzCband optical 90 -hybrids based on silicon-on-insulator 4x4 waveguide couplers," *IEEE Photonic technology Letters*, vol. 21, no. 3, pp.143– 145, February 1, 2009.