

Dynamic Simulation of Double Pipe Heat Exchanger using MATLAB simulink

¹Asoka R.G, ²Aishwarya N, ³Rajasekar S and ⁴Meyyappan N

¹²³⁴Department of Chemical Engineering
Sri Venkateswara College of Engineering, Tamil Nadu, India. 602117.

Abstract

This paper deals with the control dynamics of double-pipe heat exchanger using simulation tool. The transfer function can be taken as first order system plus dead time (FOPDT). The effect of step change in flow rate of hot water is analysed also observed its effect on the temperature of cold water and it was found that the temperature of cold water is increased with respect to the inlet step change. For any system the temperature needs to be accurately regulated to control the downstream processing's. Steady state and dynamic simulation of a double-pipe heat exchanger, in counter flow arrangement has been studied and the simulation results for step change in hot water flow rate have been discussed.

Keywords— FOPDT, step change, steady state

I. INTRODUCTION

The heat exchanger is a device used to transfer heat from one liquid to another either by direct contact or by an indirect contact. A plate or a tube type of a thermally conducting element is being used to separate the two fluids which allow transfer of heat from one fluid to another without mixing. [1] The behaviour of the heat exchanger should be predicted for transient operating condition and steady-state operating condition to reduce future possible failures and loss in maintenance costs. [2] A minimum cost heat exchanger network synthesis is a difficult process and much needed design problem. Here two things are mainly concerned, one is the flexibility and the other is the controllability. Feasible operation at different operation modes refer their flexibility and stability at a given operation mode and also transition from one operation mode to another in a safer manner refer their controllability. [3]

A simple double pipe heat exchanger consists of concentric pipes. It is commonly used in applications involving relatively low flow rates and high temperature or pressure, for which they are well suited. [4] The amount of heat transfer per section is small, that makes the double pipe heat exchangers a suitable heat transfer device in applications where a large heat transfer surface is not required. [5] A transfer type of a heat exchanger is the one in which both fluids pass simultaneously through the device and heat is transferred through separating walls. A model was formulated for a counter flow heat exchanger, which has been taken into account for the

variation of the heat transfer coefficient with respect to fluid flow rates and temperature. To know the stability of the heat exchanger the experiment was carried out and a transfer function was derived for the hot and cold water flow in the heat exchanger, simulations were done using a Proportional Integral Derivative (PID) controller and the results are shown. The experimental investigation was done for various step changes.

II. PID CONTROLLER

If there is no control to the process, the process with an overshoot and considerable delay time gives an inverse response. But in case of PID control being implemented, the problems of overshoot, delay time and inverse response are removed considerably and are controlled in the on-going process. And also a fuzzy logic controller can be used to reduce the rise time and settling time. [6] In case of Proportional Integral (PI)/PID based control, there are two control schemes present. They are multiloop control and decoupling control. In multiloop control, a controller is designed and implemented on each loop as the Multi Input Multi Output (MIMO) processes are treated as a collection of multi-single loops, and by taking loop interactions into account. The reasonable performances, robustness and structure simplicity, lead the multiloop control to be well accepted by the process control industry and this made efforts to improve the performance of multiloop PI/PID controllers. However the decentralized controller design method for PID controllers fails to show acceptable responses when there exists severe loop interactions. In the decoupling control, it requires two steps; they are design of the decoupler and design of the main loop controllers. Synthesis of a controller for a nonlinear MIMO process, that ensures optimal control (decoupling) and process variables constraints fulfilling is offered within Model Predictive Control (MPC) framework. [7]

Any type of abstract description that captures useful relevant features of a process can be said as a model.[8] Modelling can mean many different things, from the extraction of some simple features of a transient response to the development of a traditional control model in terms of a transfer function or an impulse response. Thus a model for the double pipe heat exchanger was derived and it was

simulated in MATLAB using a PID controller circuit which was tuned under Cohen-Coon tuning rules.

III. EXPERIMENTAL SETUP

This setup consists of two thin wall tubes mounted concentrically on a panel. The water flow through the annular tube can be reversed for either counter current or parallel flow. The hot water flows through the centre tube and cold water flows through the annular region.



Fig. 1: Counter Current Double Pipe Heat Exchanger

A. Construction:

- 1) Valves are used to set up desired flow conditions (rate and direction). The cold water valve was set in the correct position to achieve either countercurrent or parallel flow.
- 2) The thermometers are placed near the entrance, midpoint and exit of each pipe. The thermometers will give coarse readings.
- 3) The flow rate of the fluid is set at scale of liter/min. It is adjustable for the purpose of zeroing the reference mark on the tube. The flow rate is read for both the cold and hot water flow by turning the appropriate valves.

Water is heated by two heaters. An insulated pipe is used to pump the hot water from the tank into the inner tube. Water returns to the tank through valve 5. The cold water is supplied through the mains and drains through valves 2 and 3 in the counter flow and parallel flow conditions respectively. The counter

flow conditions are achieved by shutting the valves 1 and 3 and opening the valves 2 and 4, while the parallel flow conditions are obtained by shutting the valves 2 and 4 and opening the valves 1 and 3. Thus direction of flow and flow rates can be determined by opening or closing the appropriate valves. (All globe valves are totally opened or totally closed.) The metering valves at the outlets are used to control flow rates. The system must be allowed to reach steady state condition before taking the measurements. Five readings are taken for hot and cold flow configuration. The two heat exchanger groups must work together once the flow has been initiated because the adjustment of flow in one group will affect the other team's flows.

The overall heat transfer rate in the heat exchanger can be calculated by assuming that the heat losses from the outer tube stream as negligible. Therefore the overall rate of heat transfer is equal to either the heat released from the hot stream or the heat absorbed by the cold stream, namely [9]:

$$Q = (mc_p \Delta T)_c = (mc_p \Delta T)_h$$

Where,

- Q Heat content (W)
- m Mass flow rate (kg/s)
- C_p Heat capacity of water, kJkg⁻¹.K⁻¹
- ΔT Temperature difference, K

IV. RESULTS AND DISCUSSION

The system can be represented by first order system plus dead time (FOPDT):

$$G(s) = \frac{ke^{-\tau Ds}}{(\tau s + 1)}$$

Where,

- G(s) Transfer function
- τD Transport delay, (s)
- k Process gain, (k.s.kg-1)
- τ Time constant, (s)

The following table shows the heat exchange between the hot and cold fluid at varying hot water flow rate.

Table 1: Change in Temperature of Hot and Cold Water at Varying Hot Water Flow Rate

HOT WATER			COLD WATER		
FLOW RATE (l/min)	T_{in} (°c)	T_{out} (°c)	FLOW RATE (l/min)	T_{in} (°c)	T_{out} (°c)
1.5	71	60	1.5	33	45
2	70	65	1.5	33	49
2.5	73	68	1.5	33	53
3	75	69	1.5	33	54
3.5	74	69	1.5	33	54

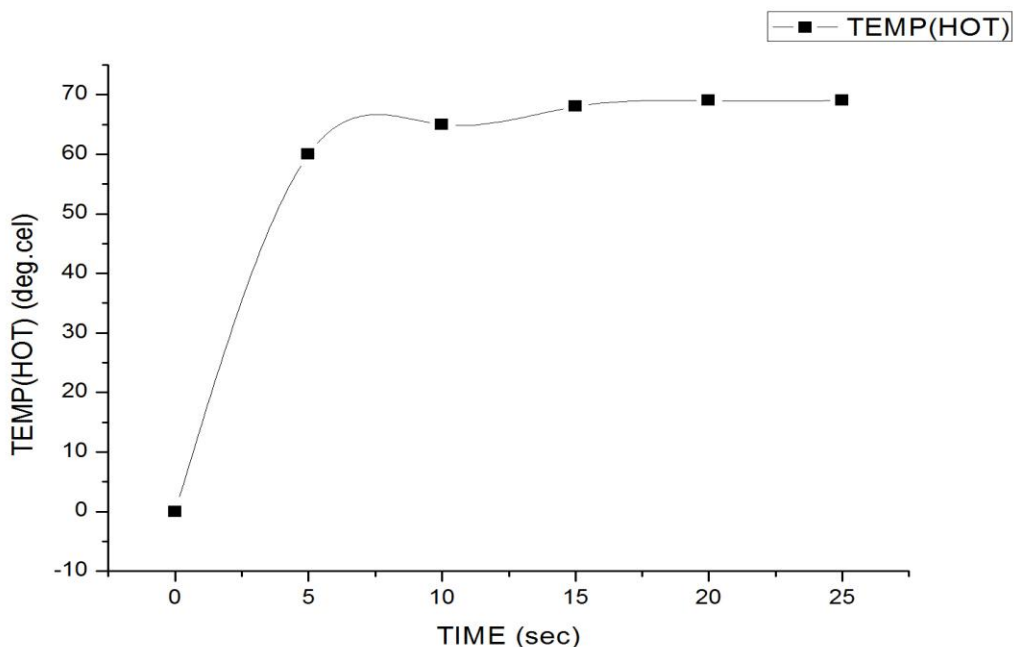

Fig. 2: Temperature Response for Step Change in Hot Water Flow Rate

The following table shows the heat exchange between the hot and cold fluid at varying cold water flow rate.

Table 2: Change in Temperature of Hot and Cold Water at Varying Cold Water Flow Rate

HOT WATER			COLD WATER		
FLOW RATE (l/min)	T_{in} (°c)	T_{out} (°c)	FLOW RATE (l/min)	T_{in} (°c)	T_{out} (°c)
3	75	60	3.5	33	43
3	75	64	3	33	46
3	75	68	2.5	33	50
3	75	69	2	33	53
3	75	69	1.5	33	54

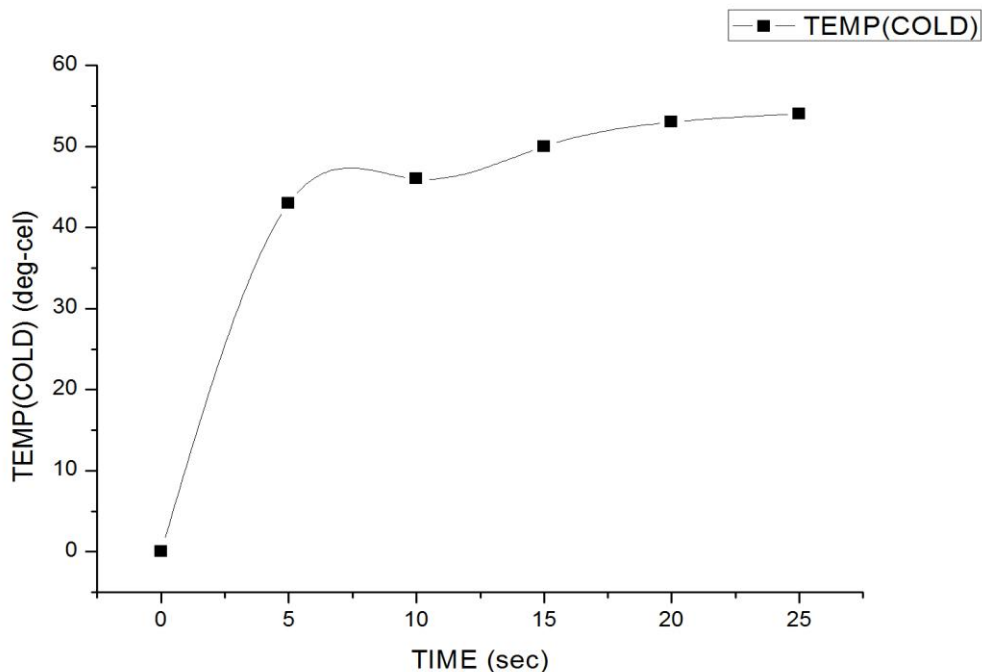

Fig. 3: Temperature Response for Step Change in Cold Water Flow Rate

A closed loop system was developed for double pipe heat exchanger and a servo problem was considered using MATLAB Simulink via 0.5 step change in set point of controlled variable which is the outlet temperature of cold and hot water stream. The

initial tuning constants K_c , τ_I , τ_D for PID controller were found using empirical model (Cohen-Coon method).

Table 3: Derived Values of Process Parameters of the Double Pipe Heat Exchanger

	Varying hot water flow rate	Varying cold water flow rate
Transfer function	$\frac{34.5}{11.5s + 1} \exp(-0.175s)$	$\frac{27}{10s + 1} \exp(-0.1s)$
Time delay	0.175	0.1
K_c	2.5469	4.9475
τ_I	0.4279	0.2451
τ_D	0.0634	0.03629

Where,

- K_c Controller gain
- τ_I Integral time of controller
- τ_D Derivative time of controller

The response of outlet cold and hot water temperatures using step change in hot water and cold water flow rates is shown in fig. 3 and 4. A process

reaction curve was used to find the process parameters.

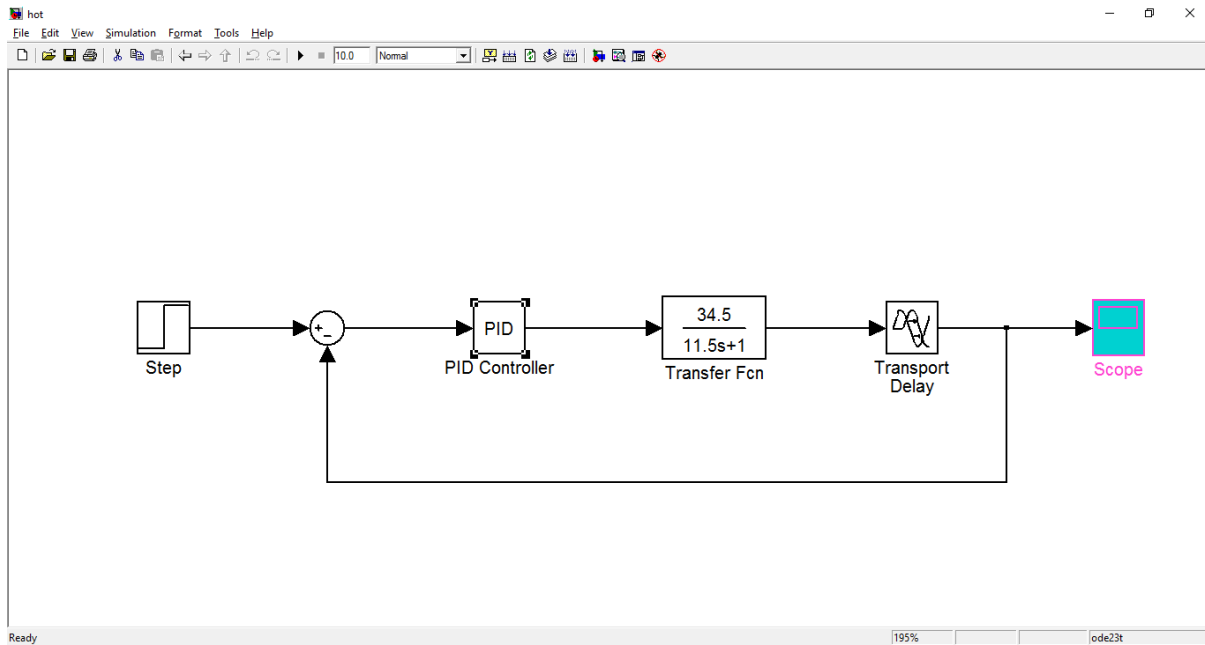

Fig 5: Block Diagram of Closed-Loop System for Hot Water Using PID Controller

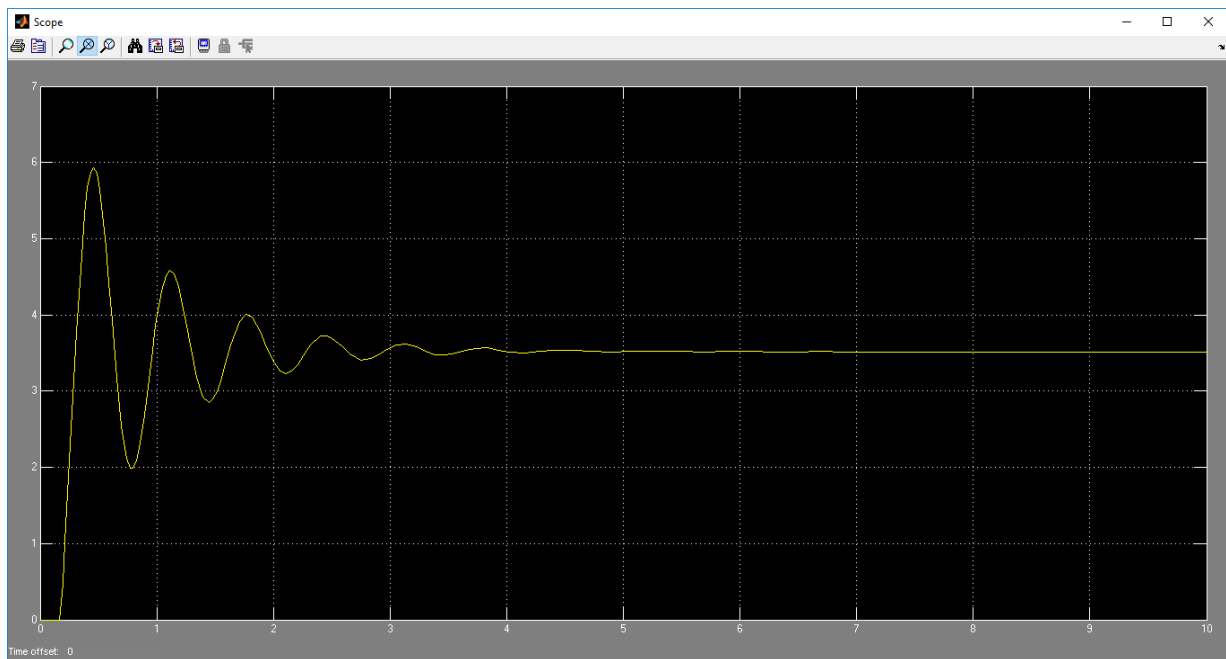

Fig 6: Response of Closed Loop for Hot Water Using PID Controller

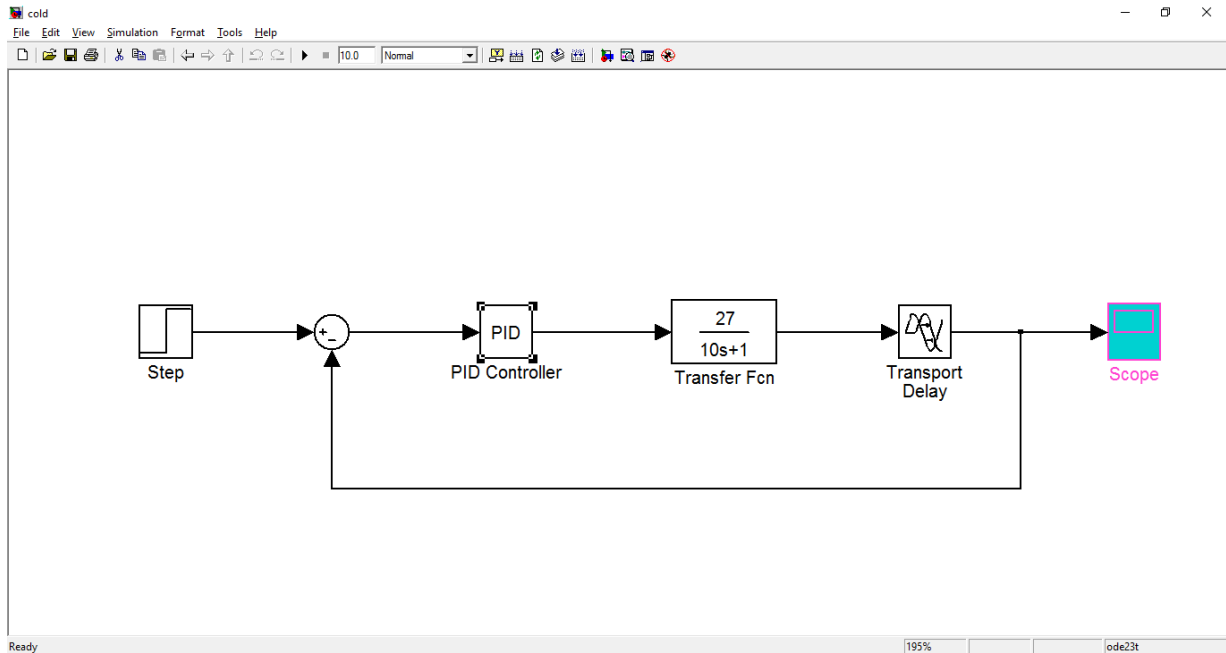

Fig 7: Block Diagram of Closed-Loop System For Cold Water Using PID Controller

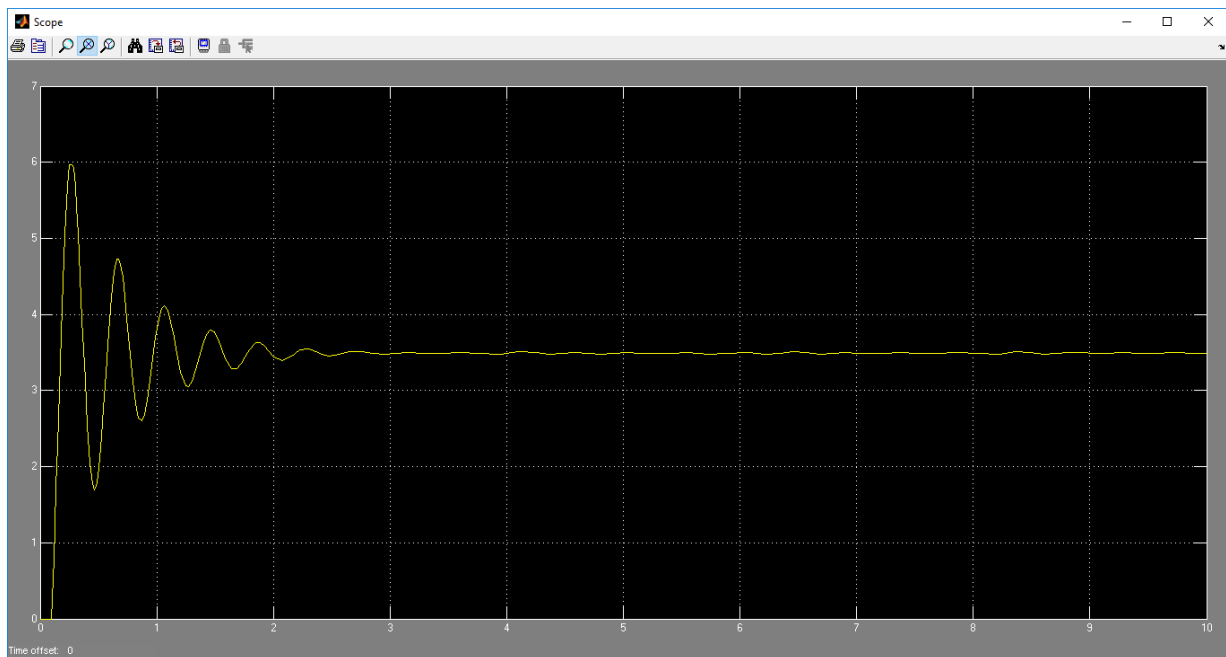

Fig 8: Response of Closed Loop For Cold Water Using PID Controller

PID controller removed the offset but the settling time response is large for the step change in hot fluid flow rate than the cold fluid flow rate. So, one can see the time required for the response curve to reach steady state contains no offset. A stability of

closed loop response using bode diagram was also studied and it indicates that the system is stable as gain and phase margin are positive.

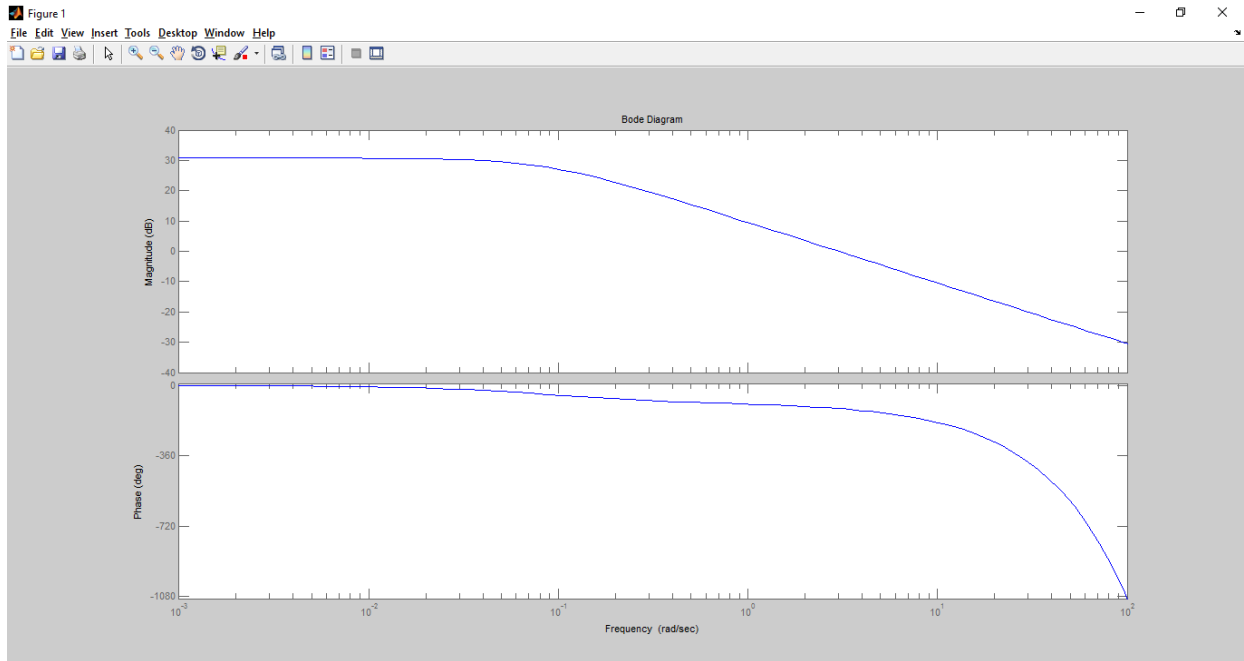

Fig 9: Bode Diagram for Open Loop System for Varying Hot Water Flow Rate

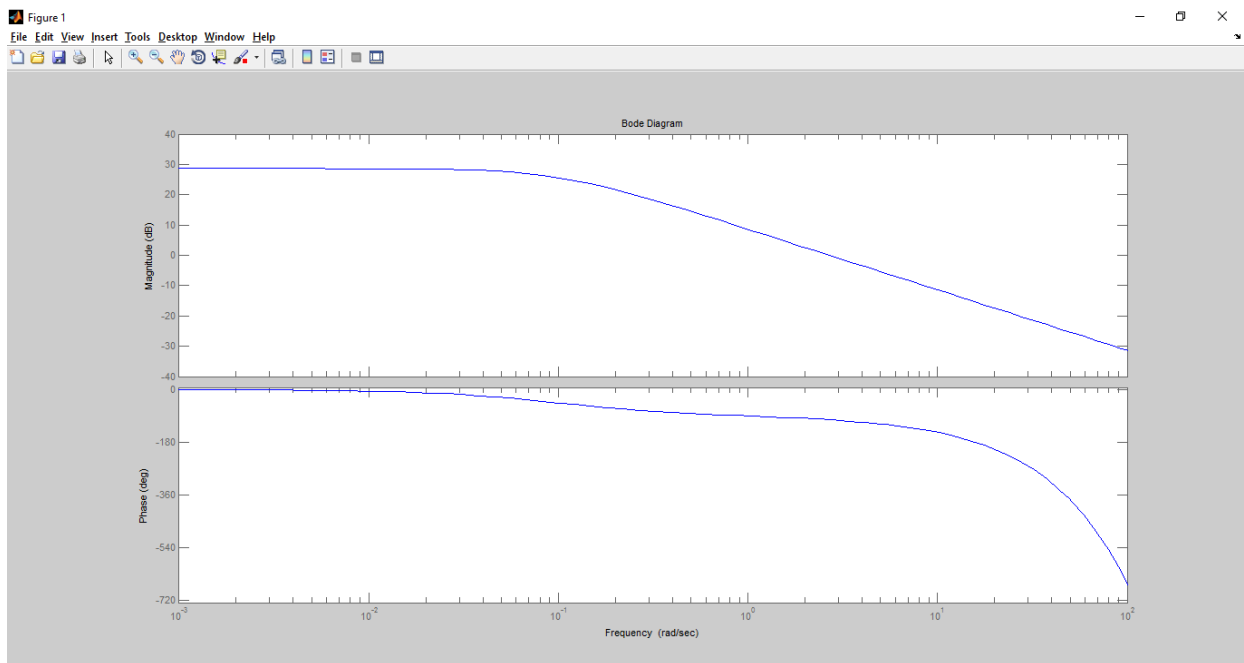

Fig 9: Bode Diagram for Open Loop System for Varying Cold Water Flow Rate

V. CONCLUSION

Steady-state and transient response of double pipe heat exchanger using PID controller in Simulink model using MATLAB has been studied for various step change in cold and hot fluid flow rates. The simulation results shows that change in cold fluid flow rate will reach steady state faster than the change in hot fluid flow rate. Heat exchange between the hot and cold fluid explained with simulation

results. Model which is developed for double pipe heat exchanger is validated with bode stability plot. The stability of the process was analyzed with bode plot results. The results show that the system is stable for given step change in hot and cold fluid flow rates as gain margin and phase margin are positive. Hence the model which is developed for double pipe heat exchanger may be considered for further studies.

REFERENCES

- [1] Agniprobo Mazumder, Dr. Bijan Kumar Mandal, "Numerical Modeling and Simulation of a Double Tube Heat Exchanger Adopting a Black Box Approach" Int. Journal of Engineering Research and Applications, ISSN: 2248-9622, Vol. 6, Issue 4, (Part - 2), pp.35-41, April 2016.
- [2] Stefano Bracco, Ilka Faccioli, and Michele Troilo, "A Numerical Discretization Method for the Dynamic Simulation of a Double-Pipe Heat Exchanger", International Journal Of Energy, Issue 3, Vol. 1, 47-58, 2007.
- [3] S. Papastratos, A. Isambert, D. Depeyre, "Computerized Optimum Design And Dynamic Simulation Of Heat Exchanger Networks", European Symposium on Computer Aided Process Engineering-2, S329-S334.
- [4] Robert w .Serth, "Process heat transfer principles and applications", Elsevier science and technology book, 2007
- [5] Abdelmessih, A. N., and Bell, K. J., "Effect of Mixed Convection and UB ends on the Design of Double Pipe Heat Exchangers", Heat Transfer Engineering, vol. 20, no. 3, 1999.
- [6] Shaocheng Tong and Han-Xiong Li, "Fuzzy Adaptive Sliding-Mode Control for MIMO Nonlinear Systems", IEEE Transactions On Fuzzy Systems, Vol. 11, No. 3, June 2003.
- [7] D. Mayne, J. Rawlings, C. Rao, and P. Scokaert, Constrained model predictive control: Stability and optimality, Automatica, vol. 36, no. 6, 789–814, June 2000.
- [8] K.J. Astrom, T. Hagglund, C.C. Hang and W.K. Ho., "Automatic Tuning and Adaptation for PID Controllers - A Survey", Control Eng. Practice, Vol. 1, No. 4, pp. 699-714, 1993.
- [9] M. A. Mehrabian, M. Hemmat, "The overall heat transfer characteristics of a double pipe heat exchanger: comparison of experimental data with predictions of standard correlations, Transactions on Modelling and Simulation", vol. 30, 2001.