

A New Powerfactor Correction Technique by using PFC Boost Converter

S.Sarath Kumar, Manoj Samal
M.Tech P.S&C, Assistant professor, dept.of EEE
Electrical Engineering Department
Centurion University of Technology & Management
Paralakhemudi, Odisha

Abstract

The necessary and sufficient condition for utilization of power is based on power quality. That is qualitative power should be transmitted from sending end to receiving end. Qualitative power is the transmission of power with negligible losses. Generally non linear loads are main source of harmonics. This thesis furnish a new scheme of compensation of the harmonic current produced by a diode rectifier in order to secure a power factor nearer to unity and regulate the DC-bus voltage. This is control technique employed one PFC Boost Converter, as it is connected in shunt with the diode rectifier in order to compensate the harmonic currents which are haggard by single phase diode rectifier. Generally non-linear loads are the main source of harmonics. The PFC boost converter draws purely sinusoidal current from source. In presence of diode rectifier the PFC boost converter draws current in such a way that the total current drawn from source becomes purely sinusoidal.

Key Words: power factor correction (PFC), Total harmonic distortion (THD)

I. INTRODUCTION

Due to the growth of nonlinear loads serious power pollution is produced & reflected in to the distribution & transmission networks. As due to increase in demand the losses are increasing from transmission and distribution criteria because of reactive power and harmonics which are main formation stone for power factor disruption. Power factor is one of the parameter affecting the power quality. Several power factor correction techniques are implemented to reducing the reactive power. PFC boost converter is connected in shunt with the diode rectifier to compensate the harmonic current and improve the power factor. Power factor correction (PFC) generally classified as of active power factor correction and passive power factor correction coming to passive, we introduce inductors and capacitors in order to improve nature of current and to separate out harmonic currents by low pass filter. Whereas active PFC is a device formulated to control the power haggard by load and to maintain unity power factor.

Generally, in now a day's boost converter is preferred because of its simplicity and excellent PF performance. The proposed PFC scheme is employed with one full-bridge diode rectifier, which is examine as non-linear load as source of harmonics and one Boost PFC Converter.

II. POWER FACTOR AND TECHNIQUE

A. Power factor

In general, Ac power system based on power factor is defined as the ratio of the real power circulating in the circuit to the apparent power, commonly we known that Capacitive loads are leading PF characteristics (current leads voltage), and inductive loads are lagging PF characteristics (current lags voltage)

B. Power factor techniques:

- Static capacitors
- Synchronous Condensers
- Filter power factor improvement
- Converters

By using these techniques to improving power factor

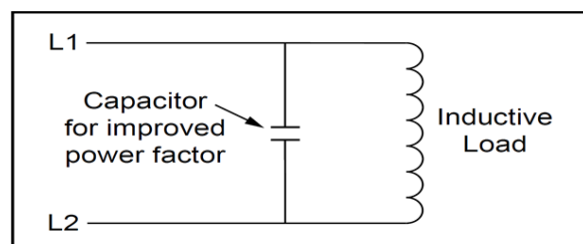

Improvement of power factor

C. Proposed power factor correction technique

The Power factor correction technique is suggests that in order to avoid harmonic problem along the line caused by a single phase diode rectifier. The proposed arrangement acts as a current source connected in parallel with the nonlinear load and controlled to produce the harmonic currents required for the load. In this way, the ac source needs only to supply the fundamental currents.

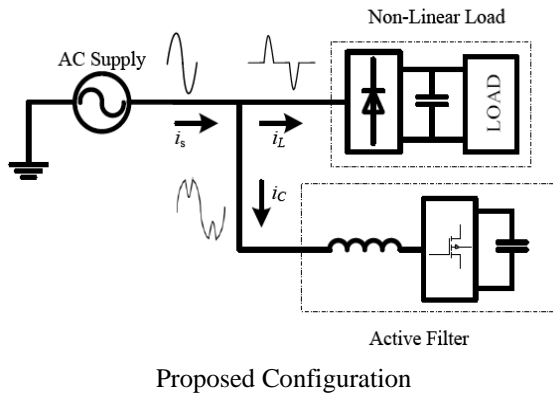

This composition consists of one PFC boost converter as it is connected in shunt with the non-linear load (diode rectifier) in order to satisfy the harmonic current drawn by the non-linear load. This technique employed a hysteresis current control technique in order trace the line current directive. So that the configuration with draws nearly sinusoidal current from source. Power switch in the intended converter are controlled in order to standoff a nearly sinusoidal line current with low distortion and low total harmonic distortion (THD) of supply current output and also regulate the DC bus voltage. In this configuration the inductor current i_c is forced to fall within the hysteresis band by proper switching the power switch 'S'. In this configuration the load1 operates in nominal DC voltage where as the load 2 operate in high voltage (i.e. more than nominal DC voltage).

III. DUAL BOOST CONVERTERS

Now a day's, Boost converters are used as active Power factor correctors. In general, current way for PFC is to employ a dual boost converter in a manner, that the individual two boost converters linked in parallel. Circuit diagrams for proposed types of PFCs are as shown below

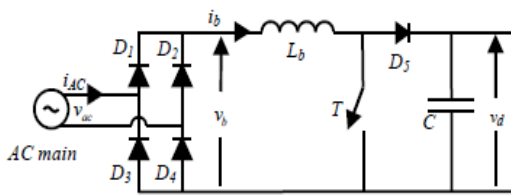

Classical PFC circuit

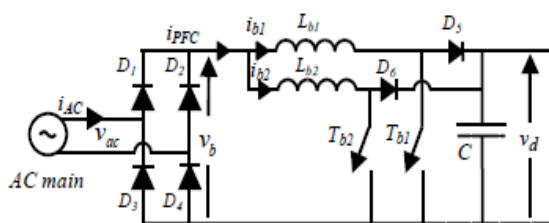

Dual Boost PFC circuit

This is one form of power factor improvement employs active circuitry in the form of a switch mode power supply boost circuit which is allocated after the diode rectifier circuit. To convert pulse rating DC into pure DC and preferable economically.

IV. CIRCUIT DIAGRAM OF BOOST CONVERTER CIRCUIT

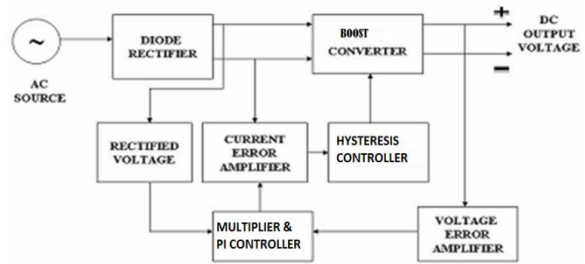

V. HYSTERISIS CONTROLLER CIRCUIT

A harmonic is a signal or wave whose frequency is an integral (whole-number) multiple of the frequency of some reference signal or wave.

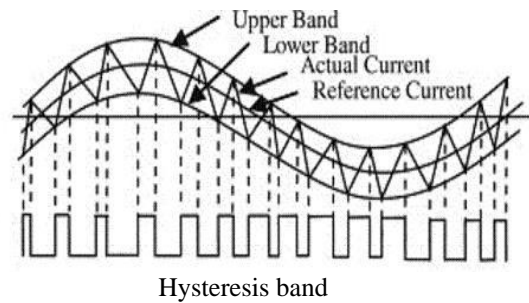

$$THD = \frac{HARMONICFR}{FUNDAMENTA} \frac{EQUENCY}{LFREQUENCY} * 100$$

IV. SIMULATION RESULT

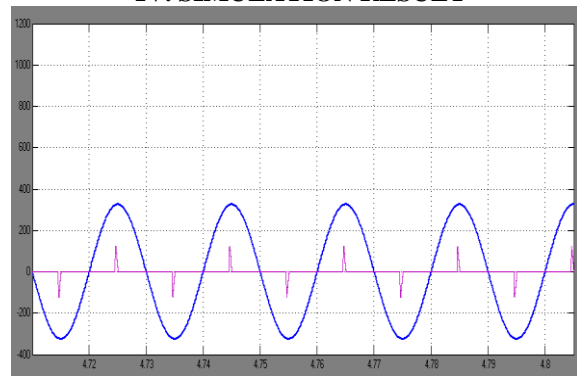

Without boost converter

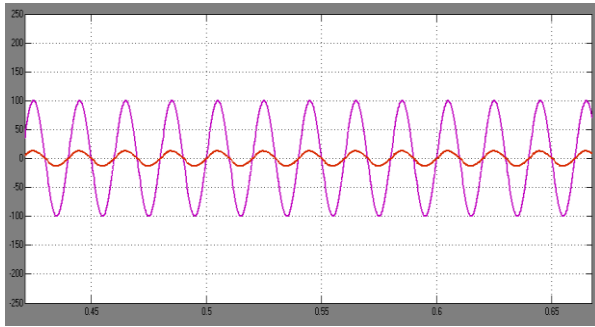

With boost converter

V. FINAL OUTPUT VOLTAGE RESULT:

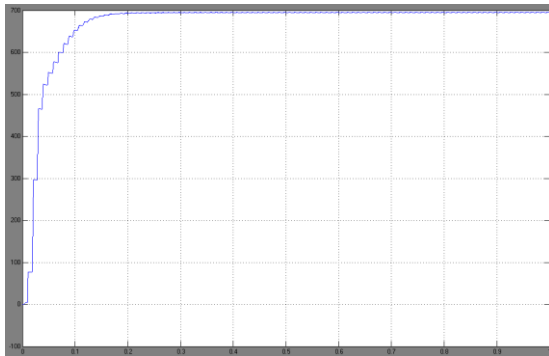

| S.No | Name | value |
|------|------------------------|--------------------|
| 1 | Supply voltage | 240v(p-p),50Hz |
| 2 | Output boost converter | 350v |
| 3 | Non linear loads | 20mH, 500Ω, 1000μF |
| 4 | Boost converter | 450μF, 100Ω, 10mH |

V. CONCLUSION

This thesis has placed a new technique approach through the AC/DC boost-type converters for PFC applications. Without employing any dedicated converter, that can be used to eliminate the harmonic current generated by the other non-linear load. Through simulation environment, we can analysed that, this arrangement removes almost all curtailed form nothing but lower order harmonics, hence with this arrangement through which we can obtain power factor nearer to unity, where almost THD less than 5%.

REFERENCES

[1] J.T. Boys, A.W. Green, “Current-forced single-phase reversible rectifier,” IEE Proc. B 136, Vol. 3, 1989, pp. 205–211.
 [2] S. Manias, “Novel full bridge semi controlled switch mode rectifier,” IEE Proc. B 138, Vol. 3, 1991, pp. 252–256.
 [3] R. Martinez, P.N. Enjeti, “A high-performance single-phase rectifier with input power factor correction,” IEEE Trans. PE 11, Vol. 2, 1996, pp. 311–317.

[4] B.R. Lin, D.P. Wu, “Implementation of three-phase power factor correction circuit with less power switches and current sensors,” IEEE Trans. AES 34, Vol. 2, 1998, pp. 664–670.
 [5] H. Akagi, A. Nabae, S. Atoh, “Control strategy of active power filters using multiple voltage-source PWM converters,” IEEE Trans. IA 22, Vol. 3, 1986, pp. 460–465.
 [6] B. R. Lin, “A single-phase three-level pulsewidth modulation AC/DC converter with the function of power factor corrector and active power filter,” Electric Power Systems Research 58, 2001, pp. 157–167.
 [7] P. Karuppanan, Kamala Kanta Mahapatra, “PI and fuzzy logic controllers for shunt active power filter,” ISA Transactions 51, 2012, pp. 163–169.
 [8] L. Rossetto, G. Spiazzi, and P. Tenti, “Control techniques for power factor correction converters,” in Proc. Power Electronics, Motion Control (PEMC), September 1994, pp. 1310–1318.