

# Performance Improvement of MIMO-OFDM Systems using V-blast and STBC

ABDUL RASHID S. PATEL<sup>1</sup>& R. D. PATANE<sup>2</sup>

<sup>1</sup>(M.E Student (EXTC), ARMIET College of Engineering, Sapaon, Mumbai, Maharashtra, INDIA)

<sup>2</sup>(Associate Professor, Department of Electronics, Terna Engineering College, Mumbai, Maharashtra, INDIA)

**ABSTRACT:**-The mobile communication systems with data rates more than 1gbps has dramatically increased in recent years. New techniques are employed to improve the performance of MIMO systems. MIMO systems with multiple antenna elements at transmitter side and receiver side is the promising technology and future for the 4G wireless systems. The techniques that can be applied to MIMO-OFDM systems are V-BLAST and STBC. Space time processing techniques falls into categories such as data rate maximization and diversity gain. In this paper we will compare BER of V-Blast and STBC using BPSK modulation in Matlab version of 2011b.

## I. INTRODUCTION

High data-rate wireless communications have attracted significant interest and constitute a substantial research challenge in the context of the emerging WLANs and other indoor multimedia networks. Wireless systems are now very popular worldwide to help people to communicate with each other. OFDM has become a popular block modulation technique which is used in combination with MIMO to make wireless communication better. It has been adopted in many wireless standards such as LAN, MAN etc[1]. OFDM is multicarrier technique and being considered as the future for 4G networks. OFDM important feature is conversion of a

Frequency - selective channel into frequency flat sub channels. The frequency separation of subcarriers in OFDM is minimum to make the two signals orthogonal in their time domain waveforms, then also signal spectra corresponding to the different subcarriers overlap in frequency. Hence, the available bandwidth is used very efficiently[2]. The combination of the two powerful techniques, MIMO and OFDM, is very attractive, and has become a most promising broadband wireless access scheme [3]. MIMO-OFDM technology has been a boon for next generation wireless networks.

## II. SPACE TIME PROCESSING

Motivated by the linear theoretical spectral efficiency improvement using multiple antennas at both ends of the radio link, enormous efforts were made to design the transmission schemes for MIMO systems. Two major techniques emerged: spatial multiplexing and space-time coding. While spatial multiplexing is used to transmit multiple independent data streams from different antennas simultaneously, space-time coding achieves full diversity gain without the knowledge of fading channel at the transmitter. The use of multiple antennas has been a recent significant breakthrough in wireless technologies. It creates a MIMO channel in which each path from one transmit

antenna to one receive antenna can be viewed as one signaling branch. MIMO systems have two major attractive advantages that conventional single-input single-output (SISO) systems do not have. These are:

*Multiplexing gain:* As supported by information-theoretic studies, the channel capacity of a multiple-antenna system is considerably higher than that of a single-antenna system. In particular, it is widely understood that channel capacity increases using multiple transmitting and receive antennas, when channel knowledge is available at the receiver at high SNR. Therefore, the degree of freedom for communications is increased. As a result, the transmission rate increases linearly. The increase is linear in the number of transmit-receive pairs, and it requires no additional transmission power or channel bandwidth.

*Diversity gain:* If the antennas at both ends have no, or very low, correlation, the signaling branches between different transmit-receive antenna pairs in a MIMO system can be assumed to be statistically independent. These independent branches create diversity gain. The basic idea of diversity is to provide the receiver with multiple replicas of the data. By transmitting the same data (in the same, or different, representations) over multiple independent branches, fading can be effectively mitigated and, hence, link reliability significantly improved [4]. The promise of deployment of MIMO has led to the development of (BLAST), and Space-Time Block Codes (STBC) to achieve some of this capacity and to improve the system reliability.

### III. V-BLAST

Due to the implementation complexity of D-Blast, a simplified version of D-Blast called as V-Blast was proposed.

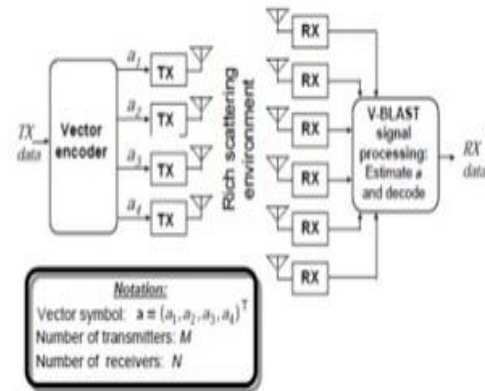

Fig 1. V-Blast Architecture

V-BLAST takes a single data stream and demultiplexes it into M sub-streams with M is the number of transmitter antennas. The sub-stream are encoded and mapped into symbols and given to a separate transmitter. The modulation method in these systems usually is M Quadrature Amplitude Modulation (MQAM). QAM is combination of phase modulation and amplitude modulation, making it an efficient method for transmitting data over a limited bandwidth channel. BLAST's receivers operate co-channel, each receiving the signals from all the transmitting antennas. V-BLAST performs a non-linear detection that extracts data streams by a ZF (or MMSE) filter  $w(k)$  with ordered successive interference cancellation (OSIC). In this paper we use Zero forcing V-Blast detection. The detection process mainly has two main operations interference Suppression (Nulling) and interference cancellation (Subtraction).

### IV. SPACE TIME BLOCK CODE

System with transmit diversity set multiple antennas in the transmitter, and it will gain spatial diversity by way of coding in different antennas [5] [6]. The space-

time block code (STBC) for two transmit antennas enjoys the following three main attractive features: 1) it does not require channel knowledge at the transmitter (i.e. operates open loop); 2) it achieves full (i.e., second-order) spatial diversity gains with a single receive antenna (which makes it attractive for the downlink); and 3) its maximum-likelihood decoder performs only *linear* processing (due to the orthogonal spatial-temporal structure of the code). Historically, the transmit diversity technique proposed by Alamouti was the first STBC. The encoder takes a block of two modulated symbols  $x_1$  and  $x_2$  in each encoding operation and maps them to the transmit antennas according to a code matrix given by

$$X = \begin{bmatrix} x_1 & -x_2^* \\ x_2 & x_1^* \end{bmatrix}$$

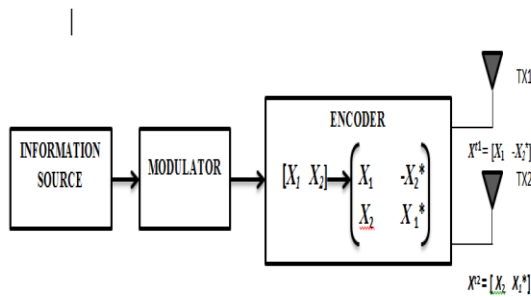

Fig 2. STBC Encoder

The important feature of the Alamouti scheme is shown in equation antennas, since the inner product of the sequences  $x_1$  and  $x_2$  is zero, i.e.

$$x^{t1} \cdot x^{t2} = x_1 x_2^* - x_2^* x_1$$

the code matrix has the following property:

$$X \cdot X^H = \begin{bmatrix} |x_1|^2 + |x_2|^2 & 0 \\ 0 & |x_1|^2 + |x_2|^2 \end{bmatrix} \\ = (|x_1|^2 + |x_2|^2) I_2$$

where  $I_2$  is a 2 X 2 identity matrix

At the receive antenna, the received signals over two consecutive symbol periods, denoted by  $r_1$  and  $r_2$  for time  $t$  and  $t + T$ , respectively, can be expressed as

$$r_1 = h_1 x_1 + h_2 x_2 + n_1$$

$$r_2 = -h_1 x_2^* + h_2 x_1^* + n_2$$

where  $n_1$  and  $n_2$  are independent complex variables with zero mean and power spectral density  $N_0/2$  per dimension, representing additive white Gaussian noise samples at time  $t$  and  $t + T$  respectively.

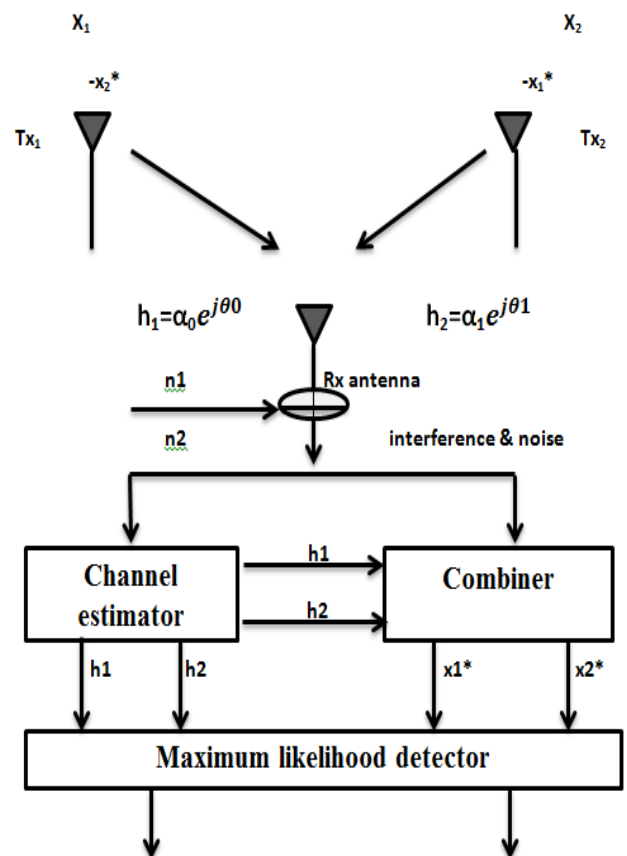

Fig 3. STBC Decoder

## V. RESULTS

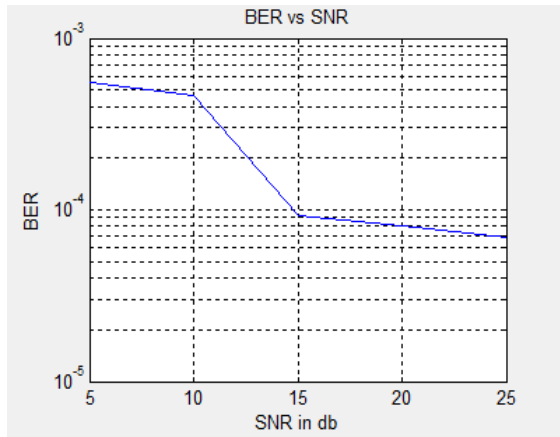

Fig 4. SNR v/s BER For MIMO-OFDM using V-BLAST

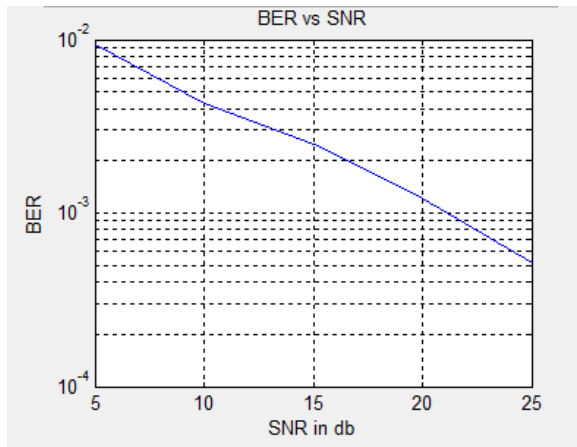

Fig 5. SNR v/s BER for MIMO-OFDM using STBC

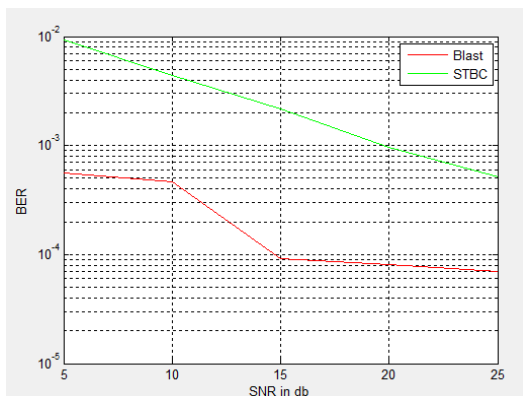

Fig 6. Comparison of SNR vs BER for Both MIMO-OFDM using V-Blast & MIMO-OFDM using STBC

In V-Blast System from the fig 4. We can observe that for 4 channel the BER is near about  $10^{-3}$ . This system is good for high speed wireless communication because the data is transmitted independently through different channel therefore time required is less to transmit the data the only disadvantage of this system is BER because at receiver side the data is weak due to fading effect. Therefore the choice of this system is depend on user. In STBC based system as shown in fig 5. the BER is  $10^{-2}$  for 4 channel we can conclude that BER is improve because in this system we have send multiple copies of data through different antenna at receiver side using MLD decoding we will get our data with less error. But in this system at same time we are sending same copies of data therefore the data transfer rate of this system is not so good.

Now we can conclude from fig 6. that by considering BER as parameter that STBC system is good for error less transmission but if we require high speed transmission we will consider V-BLAST for that. require high speed transmission we will consider V-BLAST for that.

Scheme	Spectral Efficiency	$P_e$	Implementation Complexity
V-BLAST	HIGH	HIGH	LOW
STBC	LOW	LOW	LOW

Table 1. V-BLAST V/S STBC

## **VI. CONCLUSION**

In the present work, the techniques that are V-Blast and STBC has been implemented in MIMO-OFDM systems and the performance has been evaluated on the basis of Bit error rate. The modulation used is BPSK modulation. From the results it has been concluded that for high data rate V-blast is preferred technique while for bit error rate STBC is preferred for the wireless communications.

By using high order antenna configuration space diversity can be increased, which will further decrease the BER at given SNR as compared to lower order Antenna configurations. By doing so, even higher data capacity at any given SNR can be achieved.

## **REFERENCES**

- [1] L. J. Cimini, "Analysis and simulation of a digital mobile channel using orthogonal frequency division multiplexing", IEEE Transaction on Communications, Vol. 33, Issue 7, pp. 665–675, July 1985.
- [2] Part 11: Wireless LAN Medium Access Control (MAC) and Physical Layer (PHY) Specifications: High-Speed Physical Layer in the 5 GHz Band, IEEE Standard 802.11a- 1999.
- [3] P. W. Wolniansky, G. J. Foschini, G. D. Golden and R. A. Valenzuela, "V-Blast: An architecture for realizing very high data rates over the rich-scattering channel", International Symposium on Signals, Systems and Electronics, pp. 295–300, 1998.
- [4] W. A. C. Fernando, R.M.A.P. Rajatheva and K. M. Ahmed, "Performance of Coded OFDM with Higher Modulation Schemes", International Conference on Communication Technology, Vol. 2, pp 1-5, 1998.
- [5] PAULRAJ A , NABAR R , GORE D . Introduction tospace-timewireless communication [M]. Cambridge: Cambridge University Press, 2003.

- [6] SUTO K, OHTSUKI T. Space Time Frequency Block Codes over Frequency Selective Fading Channels[J]. 2004.