

# Automatic Battery Charging in Solar Robotic Vehicle

Sagar pise, Prof. S.B.Shinde, Prof. S.S.Savkare

Department of Electronics and telecommunication, JSPM's Narhe technical campus, Pune, India  
Department of electronics and telecommunication, JSPM's Narhe technical campus, Pune, India  
Department of electronics and telecommunication, JSPM's Narhe technical campus, Pune, India

## Abstract

*This paper concentrates on the design and construction of charging system of LiPo batteries with the help of tracked solar panels. Thus a energy management system is put forward in robotic vehicle. The proposed system was undergone testing on the VANTER robotic platform. This robotic system is designed using smart host microcontroller. On this basis, our proposal makes a double sided contribution. On one side, it shows the use of construction of a solar tracking mechanism for increasing the robots power regardless of its mobility. On the other side, it has design of power system performance based on two batteries. In these two batteries, one is charging independently and other is providing energy to robot.*

**Keywords**— Li-po battery, Solar tracker, Robotic tool, Zigbee, Photo-voltaic (PV)

## I. INTRODUCTION

Robot is relate electro-mechanical machine that was guided by relate electronic circuit. It is often independent, semi- autonomous or remotely controlled. The branch of tech-nology that deals with automaton is named syntheticastuteness. The employment of robots in military contest raises moral consideration. Industrial robots sometimes incorporates a expressed arm and finish effectors that's coupled to fastened surface. In 2003, NASAs Mars investigation Rovers can initiate towards Mars in search of answers relating to the history of water on Mars. Robotic manipulators working in producing square measure samples of fastened robots. They can't move their bottom faraway from the work being done. Mobile bases square measure distinctive platforms with wheels or tracks connected. Rather than wheels, some robots use legs so as to maneuver regarding. The VANTER robotic investigation vehicle aims to boost varied aspects of the said rovers with scientific and educational functions. To establish the developed automaton (see Fig. 1), the most options and properties square measure compared, this paper is planned as follows. Successive section presents the mobile robotic system. Its main options square measure represented and its hardware and software system design square measure bestowed. Section III introduces the thought of sensible host microcontroller (SHM) for sharp power management applied to an enquiry vehicle. The following sections present the management of the battery-charging

system by suggests that of half-track star panels, that are that the most important aim of this paper; the planning of its mechanical structure, its electronic strategy and also the graphical program (GUI) square measure bestowed. Section IV aims at provided that the compulsory parameter for the batteries protective material, charging, and discharging rule, and also the PV system filler. Therefore, Section V puts into follow the developed methodology by difficult the rover power systems. Finally, the results and findings from the developed work square calculate bestowed.



Fig.1.VANTER: a Solar-Powered Robotic Vehicle

Solar energy is that the best natural store which may produce electrical energy. The electrical understanding cells engaged in calculators and satellites square measure likely for changing light of day directly into electricity. This cell is produced from con-ductive materials like Si. mostly, once light-weight strikes the semiconductor it's wrapped up and so permits the negatron power to flow freely. The most work of PV cells is it converts the photons to electrons. Connect atom of silicon has fourteen electrons, planned in 3 totally different shells. Si has the pure crystalline kind. Once energy is supplemental to pure Si, as within the type of heat for instance, it will cause some electrons to break off the bonds and leave their atoms. This method produces electrical experience in contact. 2 separate matter of Si were electrically neutral and to scale back sufferers within the field made within the Si antireflective covering is applied to those surfaces. This solar influence may be used for operating of automaton. Robots engaged in military purpose gain energy from star are helpful for complete power utilization. this may be done by victimisation star chase mechanism.

## II. SYSTEM REQUIREMENT AND TECHNICAL BACKGROUND

The rover that is to be going to be established has a set of two wheels that are rear end coupled to a plane of chassis that rotate self-reliantly.

These two wheels are functioned by permanent gear DC motor that delivers 1000 rpm with a starting torque of 2Kg/cm. Required programming for this robotic stage has three main levels. Starting level program will be carried out in Matlab language which will be performed in remote PC and gives GUI to display and control robotic vehicle. Second stage program will be carried out in C language that runs over PIC 16F877A microcontroller. The Communication between master microcontroller and remote PC will be conceded out by Zigbee protocol.

**A. PIC Microcontroller**

PIC refers to peripheral interface controller. It is family of microcontroller established by Microchip Company. It is more popular due to their low cost, wide convenience, free development tools and reprogramming in flash memory. PIC microcontroller has beautiful features and they are fit for a wide range of applications. It has improved Harvard architecture which is made by microchip technology.

PIC microcontrollers are generally used in the embedded projects. It provisions a power saving SLEEP mode. System uses PIC 16F877A for application, as it has low power feeding less than 2mA at 5V and 4mA, 20microA at 3v. It consists 10 bit analog to digital converter and two PWM modules. PIC 16F877A is used as smart microcontroller which performs two main functions. First it senses sunlight and second it controls the traced solar panels to get maximum power. It understands operated data from batteries and solar panels to control the employed mode of the charger accordingly. Due to its high concert and low power feeding, we are going to use PIC 16F877A microcontroller.

**B. Inter Integrated Circuit Bus**

It is a two wire serial bus established by Philips for simple and low-priced applications for low bandwidth. It is used to interconnect integrated circuits on the same printed circuit board. Two bus lines used by Inter Combined Circuit bus are a serial data line (SDA) and serial clock line (SCL). Each device joined to the bus is software addressable. Multi master and multi slave formation with collision action and arbitration is supported by Inter Integrated Circuit Bus.

**C. Zigbee**

Zigbee is wireless protocol used for checking control and sensory network facilities with low cost. The great benefit is that its low data rate, low power consumption. The communication with Zigbee is more safe and consistent. The systems those have less than 300 nodes, for which Zigbee 2007 is used. The Zigbee network is built over IEEE 802.15.4 and has higher level of amenities. It is targeted for

marketable and environments purpose. It has profits related to marketing also. Zigbee protocol will be cast-off to control the robot. The Battery status will be continuously monitored and sent back to the monitoring unit through Zigbee.

**III. IMPLEMENTATION DETAILS**

The main concentration of the project is solar power system will be going to function the robot. For this the power administration will consist of smart battery that associates both communication devices and electronics that are controls the charge. To accomplish this cost-effective system, cleverness will be applied to software design for simple batteries. Thus our main aim is to contrivance smart microcontroller for low cost administration system on panel a robotic vehicle. Power administration system consists of photovoltaic system, a charger device, selector system and battery system.

**A. Smart Microcontroller**

PIC 16F877A which is used as smart microcontroller, performs two main jobs that are it senses sunlight and controls the sensed solar panels to get maximum power. It understands operated data from batteries and solar panels to govern the working mode of the charger therefore [7]. Block Diagram is shown in Fig.2.

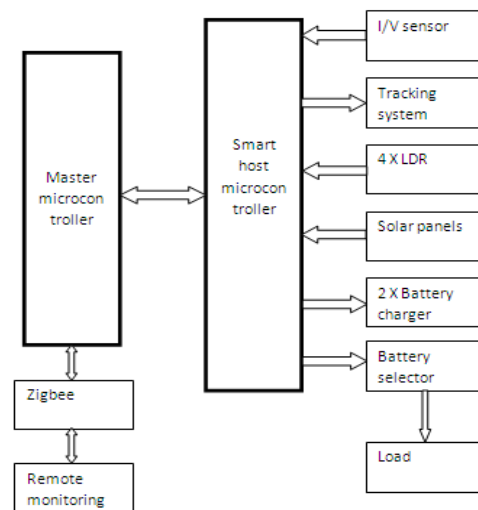

**Fig.2. Block Diagram of Hardware Architecture of System**

**B. Photovoltaic System with Tracked Solar Panels**

Light weight panel delivers lower power feeding and require enhancing the robots overall enactment. This system uses three mono crystalline solar panels with dimensions are 6.5cm X 18.5 cm for left and right panel, 19 cm X 9.5 cm for central panel. One of the main aims of our project is that application of sensed solar panels to get maximum power in PV panels shown in Fig.3. These three solar panels are run at 3 watt in which left and right panel are portable and central one is fixed.

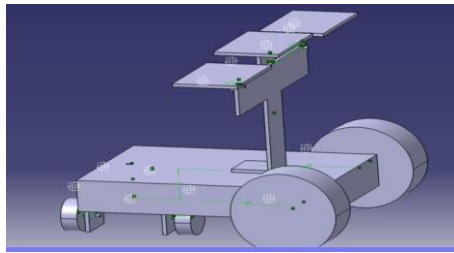

Fig. 3. Mechanical Solar Tracking System

It is confirmed that tracked solar panels gives amplified efficiency than fixed solar panels. The feeding increases agreeing to solar tracking system which is founded on servos, thus typical DC motor will be used to decrease power consumption. Mechanical solar tracking system consist of three solar panel, in which one is fixed solar panels attached straight on robotic vehicle and other two are portable panels at left and right side .

The most commanding light source can be track with the help of analog signals. They are found by the photo sensors since they already contain both amplifier and signal conditioner united circuits. Proportionate light values are compared in pairs and from their difference correcting the control signal for azimuth and promotion required by the tracking system. Each servo is organized by a pulse width modulation (PWM), whose duty cycle determines the essential rotation.

### C. Batteries Switching Mechanism

Batteries switching system involves of relays to connect charger to batteries or nonstop operation. Their main function is to link electrically charging and discharging path among batteries, the charger unit and dual battery pack. Its purpose is routing current from PV panels to the input of charger and from there to the battery nominated in each moment. Dynamic connections of electrical circuit agreed out according to logic levels cleared by master microcontroller.

### D. Batteries Monitoring System

The main moto of this monitoring system is to surge the life and energy storage capacity of Li-Po cells. Here the checking of state of charge is necessary. The main benefit of dual checking system is that it permits continuous measurement of both the capacity of battery in as charge and one being discharged.

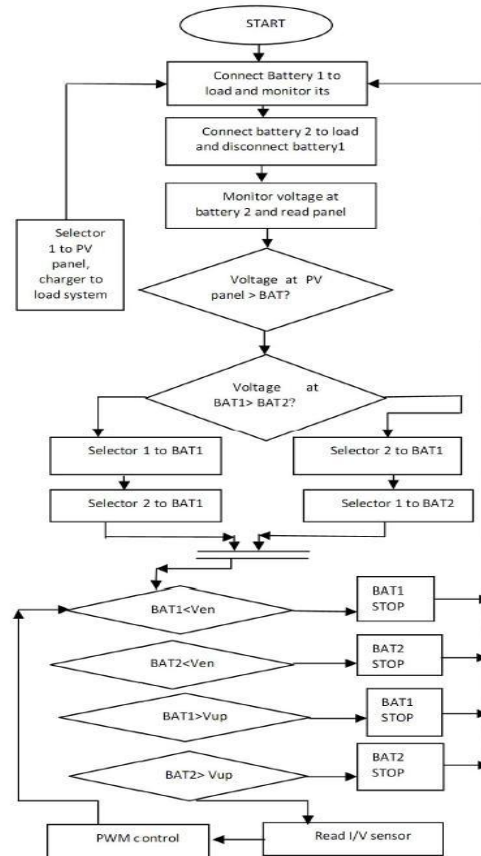

Fig. 4. Charging and Discharging Algorithm

### E. Charging and Discharging Algorithm

The charging and discharging procedure gives selection of battery one and two as shown in Fig.4. It gives evidence about charging and discharging of batteries [7]. The batteries used of 12v, 1200mA. Vup is defense condition voltage for battery charging and Ven is extreme voltage for battery discharging. Edge values for this charging and discharging guideline is defined in the SHM programmed algorithm to avoid LiPo batteries from damaging and to extend their life cycle.



Fig 5 Voltages at Battery

## IV. CONCLUSION AND RESULT

The main focus of the project is solar power system will be going to operate the robot. For this the

power administration will consist of smart battery that combines both communication devices and electronics that are able to control the charge. Power administration system consists of photovoltaic system, a charger device, selector system and battery system. PIC 16F877A is used as smart microcontroller which accomplishes two main functions that are it detects sunlight & controls the tracked solar panels to get extreme power. Light sensors are used to identify sunlight and the solar panel will rotate to appropriate side. And another is used for Battery switching. Two current sensors are used to sense the current from both the batteries. Depending on the current ratings switching action will be performed, so continuous supply will be provided to system.



Fig 6. Topview of Robot



Fig 7 Direction Control Graphics

## REFERENCES

- [1] Afarulrazi A B, Utomo W M, Liew K L and Zafari M(2011),Solar Tracker Robot Using Microcontroller, in Proc. Int. Conf. Bus. Eng. Ind. Appl., pp. 47-50.
- [2] Bajracharya M, maimone M W and Helmick D (2008), Autonomy for Mars Rovers: Past, Present, andFuture, Computer,Vol. 41, No.12, pp.44-50.
- [3] N. Smith, Dynamic power path management simplifies battery charging from solar panels, Texas Instruments, Dallas, TX, Tech. Rep. SLUA394, 2006.
- [4] Lee C Y, Chou P C, Chiang C M and Lin C F (2009), Sun Tracking Systems: A Review, Sensors, Vol.9, pp 3875-3890.
- [5] C. Zhang, D. Zeng, J. Li, F.-Y. Wang, and W. Zuo, Sentiment Analysis of Chinese Documents: From Sentence to Document Level, J. Am. Soc. Information Science and Technology, vol. 60, no. 12, pp. 2474-2487, Dec. 2009.
- [6] P SathyaPriya, P Rathi and R AnusuyaDevi,Smart Host Microcontroller Based Solar Powered Tool With Robotic Arm, International Journal of Mechanical Engineering and Robotics Research. Vol2, No. 3, July 2013
- [7] Tomas de J. Mateo Sanguino and Justo E.Gonzalez Ramos Smart Host Microcontroller for Optimal battery in a Solar Powered Robotic Vehicle, IEEE/ASME Transactions on Mechatronics, Vol. 18, No. 3, June 2013.
- [8] T. Kubota, Y. Kunii, Y. Kuroda, and M. Otsuki, Japanese rover test-bed for lunar exploration, in Proc. Int. Symp. Artif. Intell., Robot. Automat. Space, no.77, 2008.
- [9] The Rover Team, The ExoMars rover and Pasteur payload Phase a study: An approach to experimental astrobiology, Int. J. Astrobiol., vol. 5, no. 3, pp. 221241, 2006.
- [10] J. E. Gonzalez Ramos, Battery charging optimization with steerable solar cells, M.S. thesis, Dept. Electron. Eng., Comput. Syst. Autom., Universidad de Huelva, Huelva, Spain, 2010.