

Dam Water Level Monitoring and Alerting System using IOT

Kavitha.R¹, Kavitha.R², Jayalakshmi .C³, Senthil Kumar.K⁴

**1,2,3UG scholar, ⁴Associate professor,*

Department of Electronics and Communication Engineering,

Rajalakshmi Institute of Technology, Chennai.

ABSTRACT:

Far ago, human based resistive mechanisms towards flood control open up multitude problems like dynamic reactions of prior alert about the risky situations and stage of current water level. The growth of Internet of Things (IOT) paved the significant attention in all fields. The objective we propose in this paper is the application system with integration of Internet of Things to ensure the safety to the public about the prior alerting of flood occurrence due to the increase in the water level in dams/reservoirs. To achieve the objective cloud database technique is maintained which encapsulate the periodic monitoring water level data and vicinity information. The sensor data is collected periodically that are uploaded to the cloud database where the automatic comparison analytics about the increase in water level is noted. Thus, the prior stages of rise in water level are automatically alerted to the public respectively. Finally, it was observed that the level of accuracy is grown by this technique in comparison with ordinary method of monitoring and alerting system.

Keywords: Internet of Things, water level, stage - wise warning caution.

1.INTRODUCTION:

In India nearly 4000 major/medium dams are constructed and many more are in a pipeline. Normally, the range of dam storage capacity of 185 billion cubic meters of water with a surface area of 5,580km (93.4TMCft). During rainfall, for every

9.6mm the rise of water level increases by 0.3ft. In the recent analysis by the BC dam safety annual report, from the year 2011-2016 number of dam incidents, dam alerts and dam failures are decreased respectively. With the growing interest in Internet of Things has become a right choice for the pre-alert system for monitoring the rise in the water level in dams. The risk rate of sudden flood occurrence opened up a way for the way the need of the real-time dam water level monitoring and prior alerting system which ensures the public safety. The main purpose of the system carries out an advantage of transfer of information both of the cloud and public smartphone using local Wi-Fi.

2.LITERATURE REVIEW:

The recent works on the Internet of Things and Cloud Computing ensures fast data transmission speed and cloud data integration platform, to achieve the real-time monitoring [2]. The applications of wireless sensor network and IoT to monitoring water level ensures remotely observation [5]. The IoT based analysis ensures accuracy and response time [1]. Flood due to rise in water level is noted as dangerous action which incorporates the integration of IoT platform for the flood monitoring and pre-alerting system. Water level change estimation using WNN ensures the valid testing analysis [6]. For water level change forecasting gives the availability of water level data and current outflow data using neural network system. The common approaches for the alerting and controlling techniques for flood occurrence in dam leads to the increase risk factor

[4].Researches on IoT based flood monitoring and controlling investigated the accuracy and feasible nature of the acquired data.

3.METHODOLOGY:

HARDWARE DESIGN:

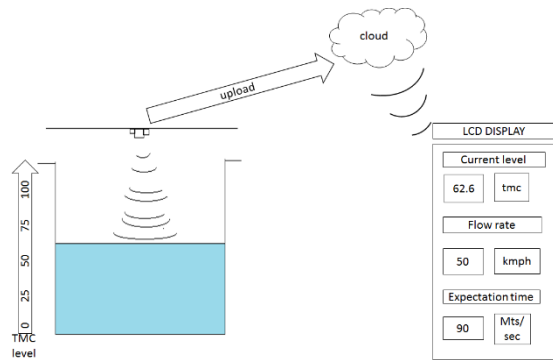

Figure: a) Structure of the operation in the system.

The Internet Of Things (IOT) has become superfluous technology that could replace humans based strains who were in charge of monitoring and maintaining supplies. The Hardware of the proposed system consists of Node mcu microcontroller development board, Ultrasonic Sensors, to collect & transfer data to cloud. This system is using Wi-Fi module (Esp8266) to send the sensor data to the cloud. All the sensors are connected with Wi-Fi module. So here the Mobile data or Wi-Fi is the access point for the internet. And after all, this data sends to the cloud (Thing Speak).

3.2 SOFTWARE DESIGN:

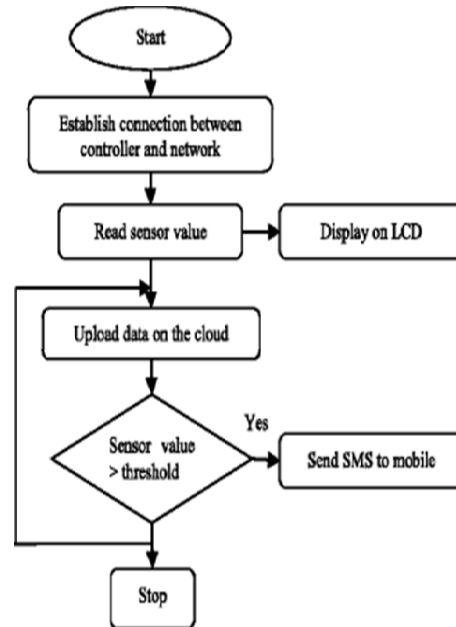

Figure: b) Structure of the flow of operation of the system.

Then the data is compared with initial threshold level. If it reaches threshold value, the primary message alert is given to the public through GSM and also displays the flow rate, time taken to get overflowed in LCD. Consecutively, the system gives further alert when the possibility of danger increases. The details of the people is stored in cloud database and which is accessed during the crisis. The schematic block diagram of the system clearly explains the working operation of the system. This alerting system ensures the public safety with high level of reduction in life loss and damage to the large properties.

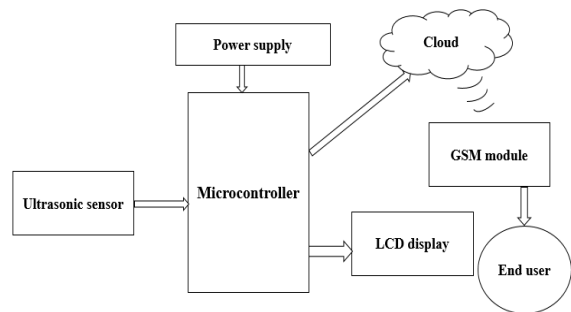

Figure: c) Schematic block diagram of the system.

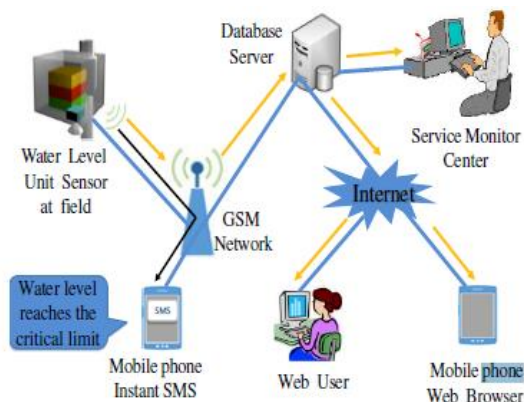

Figure: d) Overview of the system design

4.RESULTS:

The results obtained in the above discussed objective encapsulates both monitoring water level for each stage of level increase in dam/reservoirs and pre-alert caution for the stage wise water level increase to the public. The finding of this study has produced the level of accuracy and feasibility nature of IoT based reservoir water level. The massive water level increase is noted and warned public by using the growing technology to protect the livelihood of people in that habitat. Further study about the system gives the outflow of dam water to the yields.

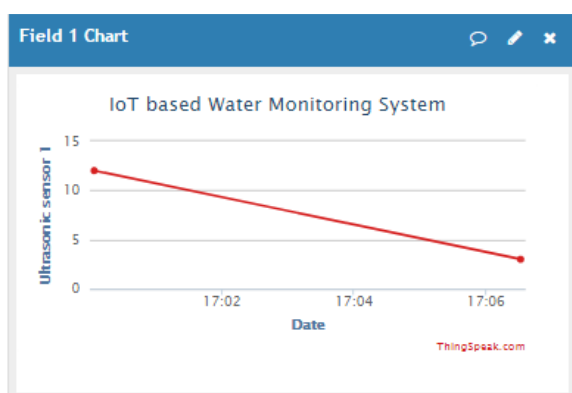

Figure (e): ThingSpeak Result for Ultrasonic sensor.

5.CONCLUSION AND DISCUSSION:

By the growth of IoT platform in various fields encourages the reduction of human life loss and damages to the properties caused by both natural and human-made disasters. The key advantage of IoT

paved the way for dynamic safety with high level accuracy in performance and feasible nature data analytics. Adoption of new technology conveys the proper condition about the mishap. The response of the system is fast for the change in input. Thus, the study provides an IoT based monitoring and alerting of dam water level by using various past research contributions and issues remedy mechanisms which enables the smart warning technique for public safety.

6.REFERENCES:

- 1) Partha pratim ray, mithun mukherjee and lei shu(member IEEE)“*Internet of Things for disaster management: state-of-the arts and prospects,*” under Grant 61401107 and 517018,july 2017.
- 2) Longjung dong(member IEEE),weiwei shu,sun,xibing li and zhang,”*Pre-alarm system based on Real-Time Monitoring and Numerical Simulation using Internet of Things and Cloud Computing for Tailings dams in Mines*”,under Grant 2016QNRC001 and 201613,published in oct 2017.
- 3)Ghatan,Abdalkareem Ammar and Badia,Yousef Haider,”*Water level prediction in 16th tishreen dam reservoir usin artificial neural networks*” published in American Journal of Innovative Researcand Applied Sciences,may 02,2017.
- 4) Mosbeh R Kaloop, Mohammed El Diasty ,Jon Wan hu,”*Real-time prediction of water level change using adaptive neuro-fuzzy inference system*”, published in Geomatics, natural hazards and risk,2017 Vol.8,no-2,1320-1332.
- 5)Hamra Afzaal and Nazir Ahmad Zafar,”*Cloud Computing based Flood Detection and Management system using WSN’s*”, *IEEE journal*, published in 2016.
- 6) Nur Atir ashaary, Wan hussain Wan Isak and ku ruhana ku,”*Neural Network Application in the change reservoir water level stage forecasting*”, published in Indian Journal of technology, Vol 8(13), July 2015.
- 7)Thinagaran Perumall, Md Nasir Sulaiman, Leong.C.Y,”*Internet of Things (IoT) Enabled Water Monitoring System*”published in 2015 IEEE 4th Global Conference on Consumer Electronics (GCCE).

8) Daniel wu, fakhreddine karray and Insop song," *Water level control by fuzzy logic and neural networks*", published in IEEE journal in July 2014.

9) Maarten breckpot, Oscar Mauricio and Bart DE moor," *Flood control wit model predictive control for river systems with water reservoirs*", published in journal of irrigation and drainage engineering /ASCE, July 2013.

10) Thinakaran Perumal, Md Nasier Sulaiman, Leon C.Y " *Internet of Things(IoT) Enabled Water Monitoring System*", published in 2015 IEEE 4th Global Conference on consumer Electronics(GCCE).

11) Daniel wu, Fakhreddine karray and Insop song," *Water level control by fuzzy logic and neural networks*", published in IEEE journal in July 2014.

12) Maarten Breck pot, Oscar Mauricio and Bart DE moor," *Flood control wit model predictive control for river systems with water reservoirs*", published in journal of irrigation and drainage engineering /ASCE, July 2013.

13) Ramli Adnan, Fazlina Ruslan, Samad and Zainazlan Md Zain," *Artificial Neural Network Modelling and Flood Water Level Prediction using Extended Kalman Filter*", dept of Surveyin Science and Geomatics , published in 2012 IEEE conference on control system and computing engineering.

14) Zhang Ji and Qi Anwen," *The Applications of Internet of Things in Emergency Management system in china*, published in IEEE 2010.