

Design and Evaluation of Potter-Turin Corrugated and Noncorrugated Ku Band Terrestrial Communication Antennas

¹Mr.R.Shankar, ²Ms.J.K.Jerioth

¹Associate Professor, Department of ECE, Kongunadu college of Engineering and Technology
Trichy, India

²PG Student, Department of ECE, Kongunadu College of Engineering and Technology
Trichy, India

Abstract

Design and Evaluation of Ku band conical horn antenna using Computer Simulation Software is analyzed with experimental results. Ku band Conical Horn Antennas are used for satellite communication and military application with marine technology that depends on geographic discovery. The design improves gain, directivity and extend the application. Return loss is reduced by altering the walls of the conical horn antenna. Realized gain is improved and matches with normal gain by reducing the return loss. Operating frequency for the Ku band communication antenna is 15GHz. The Turin and Potter designs are employed with and without corrugation for improving gain and directivity.

Keywords—Horn antenna, Ku band, Return loss, Directivity

I. INTRODUCTION

Horn Antennas are used for calibration and testing of other type of antennas. It is a standard gain antenna. For example, Reflector Antenna and Parabolic Reflectors make use of Horn Antenna for calibration. Antenna is used for longer distance wireless communication. It converts electromagnetic waves to electrical signal at the receiver antenna and simultaneously, converts electrical signal into electromagnetic waves. Terahertz communication generally utilizes Horn Antenna. Conical Horn antenna is formed by flaring the circular waveguide at the output end. The radiation occurs at both horizontal and vertical direction according to the flaring. The flaring of the circular waveguide decides the output effectiveness. Decrease in flaring radius decreases the circular radiation and increasing the flaring radius increases radiation at all the angle. However, the concentration of radiation at a particular angle increases with small flaring and decreases with increased flaring. Radiation efficiency and directivity of the beam is improved by providing an extended aperture for the waveguide. The wave is gradually transformed from an abrupt discontinuity by the aperture extension of the waveguide. The energy of radiation in forward direction thus

increases. It is defined as flaring of the circular waveguide. Generally, Horn Antenna is operated at 300MHz to 30GHz. This can also be denoted as Ultra High Frequency to Super High Frequency. The radiation is formed from the energy of the beam this in turn increases the focusing of the beam. The directivity of the antenna is improved by reducing the diffraction that linearly depends on the flaring of the waveguide. Smooth walled antenna provides narrow band of radiation but corrugated antenna provides wide band of frequency. Potter type antenna is the best known smooth walled antenna. Turin type antenna consist of cylindrical flaring at the end of the circular waveguide. A Horn Antenna corrugation is designed as a complicated geometry. Radiation pattern of the antenna contains main lobe and side lobe. The main lobe is the radiation pattern in the forward direction and side lobes or minor lobes are the radiation in backward direction. Minor lobes are the reason for gain decrement.

A. Software tool used

Antenna can be designed with number of software simulation tools. However, Computer Simulation Software tool is used for designing of Conical Horn antenna with smooth wall and corrugation. It is user friendly and allows the user to modify the components at any cause. It also produces number of result calculation such as Voltage Standing Wave Ratio, S Parameter, Energy, Power, angular beam width, Radar cross section calculation, Efficiency and far field. The electric field and magnetic field for the Horn Antenna can also be generated in 2-D, 3-D schematic, polar plot, X Y plot in Smith chart. Integrating the power aperture gives the directivity of the antenna.

B. Parameters used

The parameters that is fixed for the antenna design analysis are the outer and inner radius, height of the waveguide and antenna, field monitor, time domain, waveguide ports, boundaries and frequency. The antenna designs are performed at the units of

millimeters, Gigahertz, milliseconds, kelvin, center frequency, ohm, Pico Farad and Nano henry.

II. DESIGN AND SIMULATION

The antennas are modeled in the Computer Simulation Software tool that provides the return loss along with the gain and directivity. The main goal is to increase the frequency of operation with improved gain. The operating frequency is between 12GHz to 18GHz. The design of the antenna operate at 6GHz of bandwidth centered at 15GHz with low return loss.

A. Turin without Corrugation

Turin design of the Conical Horn Antenna is formed with the circular waveguide in which, the waveguide is flared high at the end for few millimeters. The end of the flaring is extended with the cylindrical flaring for large length in millimeters. This design forms the Turin Conical Horn Antenna.

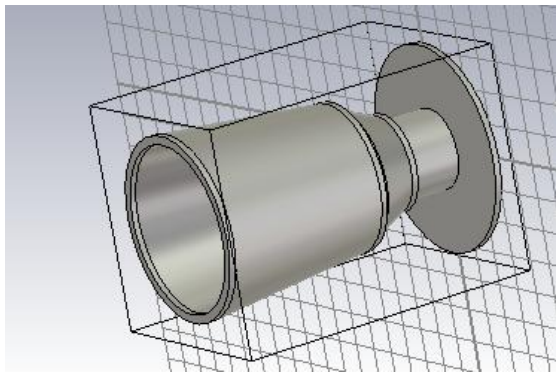

Fig. 1, Turin Conical Horn Antenna without Corrugation

Parameters of the antennas are designed in such a way that it gives minimum return loss. The return loss of the Turin smooth walled Conical Horn Antenna in the operating bandwidth of 12-18GHz is less than -30dB.

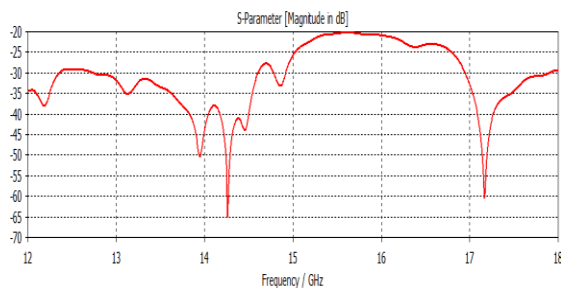

Fig. 2, Simulated Return Loss Characteristics of Turin Conical Horn Antenna without Corrugation

The Return Loss of the Turin design is much less as compared to normal Conical Horn Antenna. The Return loss is marked by plotting the graph between S Parameter magnitude and Frequency of operation.

B. Turin with Corrugation

Turin with Corrugation is formed with the same design as the Turin without corrugation except the fact that the walls of the Conical Horn Antenna is not smooth. Square wave like structure is formed at the conical walls of the Antenna. This is design is complicated than Turin without Corrugation. However, it provides higher gain with minimum Return Loss. The Antenna is designed with same radius and flaring as smooth walled Turin. The square walls are formed by inserting free space on the walls of the Perfect Electric Conductor. The perspective view of the Turin with Corrugation design shows the clear view of the corrugation inside the walls. The Perfect Electric Conductor is used for entire design of the Antenna.

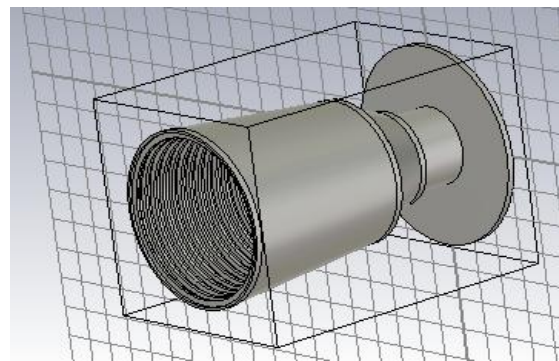

Fig. 3, Turin Conical Horn Antenna with Corrugation

The return loss of the Turin design with same parameter and operating frequency is high as compared to smooth walled Turin. The return loss of the corresponding design operated at bandwidth of 12-18GHz is less than -18dB.

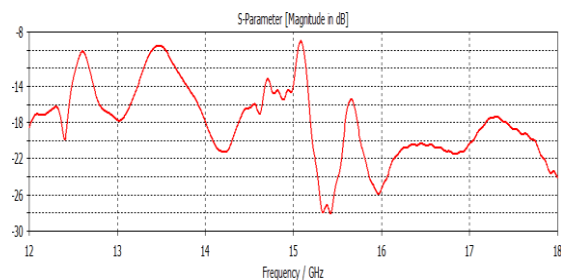

Fig. 4, Simulated Return Loss Characteristics of Turin Conical Horn Antenna with Corrugation

C. Potter without Corrugation

The Potter design of the Conical Horn Antenna without corrugation can be formed by flaring the circular waveguide slightly for few millimeters that looks like a cylinder. The flared waveguide is again flared that makes it appear as a cone for large angle. The latter flaring occurs for larger millimeters as compared to the first flaring.

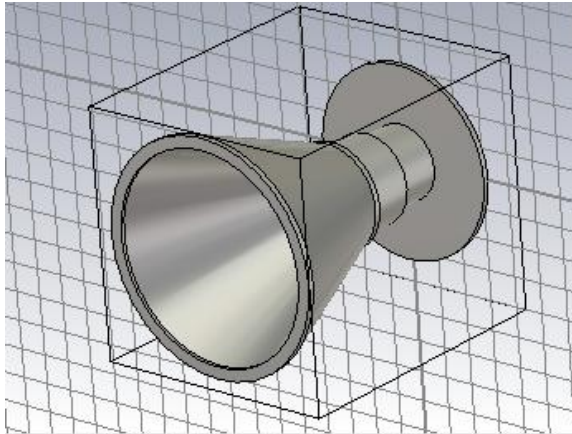

Fig. 5, Perspective view of the Potter Conical Horn Antenna without Corrugation

The parameters for designing the Potter Conical Horn Antenna is same as that of the Turin Conical Horn. The Return Loss of the Potter Conical Horn Antenna is less as compared to the Turin design. The Return of the Potter Conical Horn antenna without Corrugation operating at the band of frequency 12-18GHz centered at 15GHz is less than -36dB.

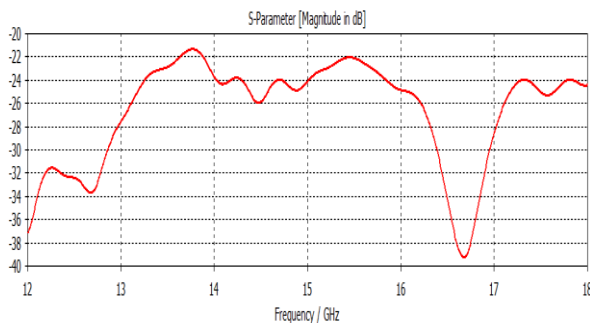

Fig. 6, Simulated Return Loss Characteristics of Potter Conical Horn Antenna without Corrugation

The reduction in Return Loss decreases the variation between the realized gain which includes loss and normal gain without including the loss.

D. Potter with Corrugation

Potter with Corrugation design is similar to smooth walled Potter design except that the walls are employed with free space and PEC alternately. The Potter Conical Horn Antenna with Corrugation is complex as compared to Turin Conical Horn Antenna with Corrugation.

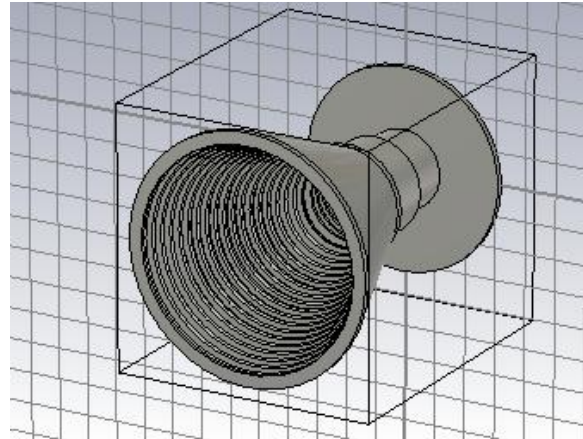

Fig. 7, Perspective view of the Potter Conical Horn Antenna with Corrugation

The Return Loss for the Potter design in which the walls of the antenna are corrugated that operates at the center frequency of 15GHz with bandwidth 6GHz is less than -10dB. The corrugation design increases the Return Loss of the antenna. It is greater than the Return Loss of Turin with Corrugation on the smooth walls. The corrugation present inside the walls are visible in the perspective view. The simulation shows peak variation in Return Loss graph that is caused by corrugation.

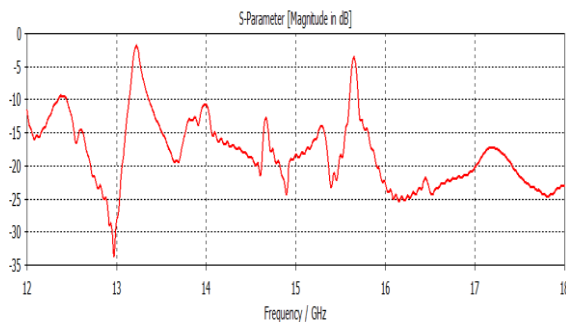

Fig. 8, Simulated Return Loss Characteristics of Potter Conical Horn Antenna with Corrugation

III. RESULTS AND ANALYSIS

The simulated results of electric field and 3-D radiation pattern of the far field gives the gain, directivity, realized gain and power pattern. Boundaries are set to the magnetic field at the YZ plane. It is the symmetric plane. Magnetic field radiation in the far field is less and the electric field is high. When the electric field increases the gain of the antenna increases.

A. Result of Smooth Walled Turin

The smooth walled Turin Conical Horn Antenna gives higher gain as compared to Pyramidal Horn Antenna. However, the gain of the normal Conical Horn Antenna is more than that is given as 31dB. Including the return loss that is called as the ratio of input power to the output power along with the loss

which is called as the realized gain is less. The realized gain of the normal Conical Horn Antenna is 11dB. This indicates that the return loss due to the back lobe is high. The back lobe magnitude is higher than that of the main lobe magnitude in terms of decibel. This loss is reduced by the modulated design called smooth walled Turin.

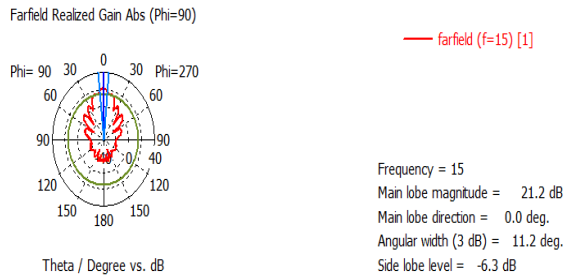

Fig. 9, Simulated E-Plane Radiation Pattern of the Turin Conical Horn Antenna without Corrugation

The radiation pattern shows that the main lobe magnitude is 21.2dB which is centered at the frequency 15GHz. The loss occurred due to the side lobe level is -6.3dB which is less as compared to normal Conical Horn Antenna.

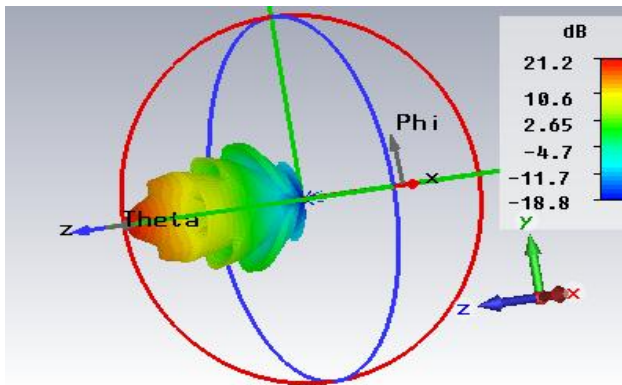

Fig. 10, Simulated 3-D Radiation Pattern of the Smooth Walled Turin

The Realized gain of the Turin smooth walled Conical Horn Antenna is 21.2dB. The normal gain of the Turin without Corrugation not including the side lobe magnitude is 21.23dB. The directivity of the designed antenna is 21.29dBi.

B. Result of Turin Corrugated Horn Antenna

The Turin Conical Horn Antenna without Corrugation gives greater gain as compared to the Turin without Corrugation.

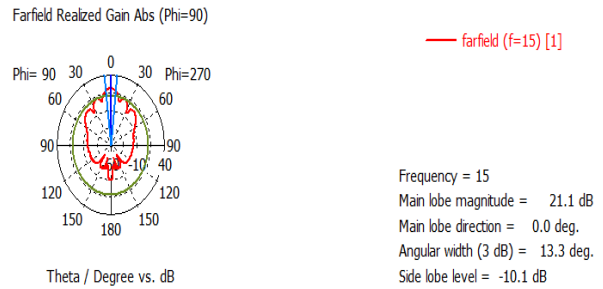

Fig. 11, Simulated E-Plane Radiation Pattern of the Turin Conical Horn Antenna with Corrugation

The Electric Field present in the given polar plane shows that the main lobe magnitude is 21.1dB. The loss due to the side lobe radiation is -10.1dB. The decrease in the side lobe level increases the equality between the realized gain and the normal gain without including the loss.

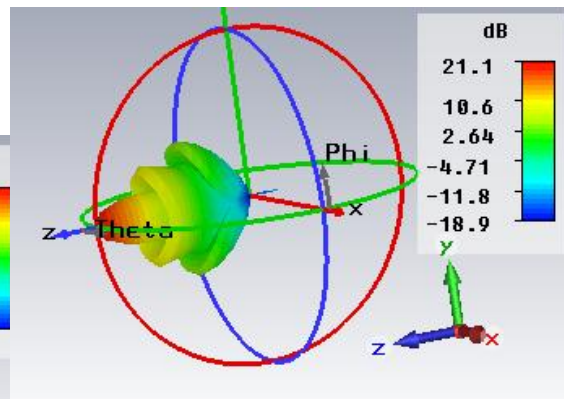

Fig. 12, Simulated 3-D Radiation Pattern of the Corrugated Turin Conical Horn Antenna

The realized gain of the Corrugated Turin Conical Horn Antenna is 21.14dB. The normal gain of the Turin with Corrugation is 21.32dB. The difference between the normal gain and the realized gain is more. Compared to the Turin without Corrugation the realized gain of the Turin with Corrugation is less. The directivity is calculated as 21.32dBi. Back lobe is reduced in the case of corrugation.

C. Result of Potter Horn Antenna without Corrugation

The Potter Conical Horn Antenna with smooth wall on the circular waveguide produces radiation pattern in the electric field is strong in the main lobe direction. By comparing to the Turin design the gain of the potter is small. The design is simple as compared to the Turin design.

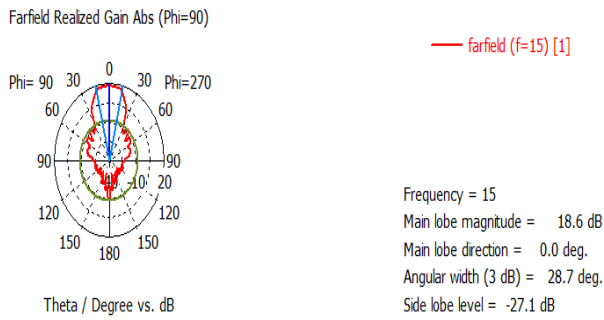

Fig. 13, Simulated E-Plane Radiation Pattern of Potter Conical Horn Antenna without Corrugation

The polar plot shows that the magnitude of the main lobe is 18.6dB at the frequency centered at 15GHz. The side lobe level is -27.1dB. Loss is much more less in case of the Potter design. The gain including the return loss is equal to the that of the normal gain as the side lobe level is low. As the return loss of the Potter without corrugation is less than -36dB the matching between the gain and realized gain is equal. In the case of corrugation and smooth walled design the return loss is higher in corrugation. However, the gain is increased in corrugation compared to smooth walled.

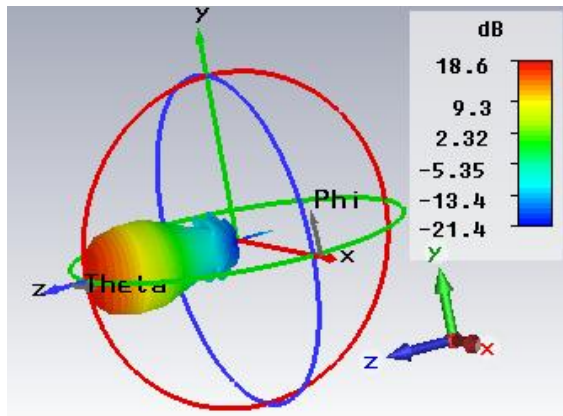

Fig. 14, Simulated 3-D Radiation Pattern of Potter Conical Horn Antenna without Corrugation

The realized gain of the Potter without Corrugation as given in the 3-D Radiation Pattern is 18.6dB. The normal gain of the design is equal to that of realized gain. There is slight variation in the gain because of return loss less than -36dB. The directivity of the antenna is 18.65dBi.

D. Result of Potter Conical Horn With Corrugation

The Electric field of the Potter Conical Horn Antenna with Corrugation is highly concentrated on the Z axis and depends on the Y plane. The magnetic field on the symmetric plane YZ is set to zero. Therefore, the value of the magnetic field at the forward direction is negative.

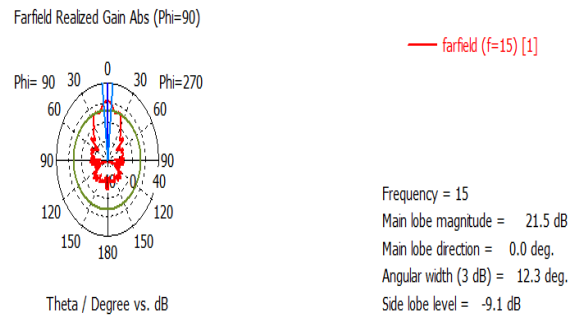

Fig. 15, Simulated E-Plane Radiation Pattern of Potter Conical Horn Antenna with Corrugation

The main lobe magnitude of the corrugated Potter design is given as 21.5dB. This radiation pattern has higher magnitude as compared to all the other design. The side lobe level of radiated electric field is -9.1dB. In alternate to the Turin design the corrugated Antenna posses higher side lobe level as compared to the Potter. In the Turin design the side lobe is higher in smooth walled compared to the corrugation. In the case of the Potter design the corrugation posses higher side lobe level than the smooth walled.

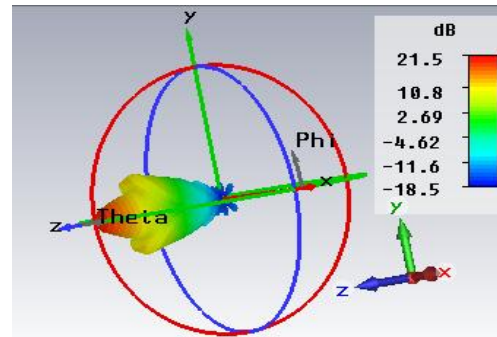

Fig. 16, Simulated 3-D Radiation Pattern of Potter with Corrugation

The normal gain of the Potter with Corrugation is 21.6dB where the realized with the bandwidth of 6GHz centered at 15GHz is 21.5dB. The directivity of the same design at the given frequency is 21.64dBi.

Table I. Analysis of Result

Name	Parameters			
	Gain in dB	Realized gain in dB	Directivity in dB	Return Loss in dB
Turin without Corrugation	21.23	21.2	21.29	-35
Turin with Corrugation	21.32	21.14	21.32	-18
Potter without	18.6	18.59	18.65	-37

Name	Parameters			
	Gain in dB	Realized gain in dB	Directivity in dB	Return Loss in dB
Corrugation				
Potter with Corrugation	21.6	21.5	21.64	-12

The analysis of all the four design is shown in the table above in which the Potter Conical Horn Antenna with Corrugation generates higher realized and normal gain of 21.5dB and 21.6dB. similarly, the directivity of the Potter Corrugated design is high. The return loss of the Potter Conical Horn Antenna without Corrugation is less compared to all the other design. The results can be further improved by employing the profiled design which is a little more complicated with corrugation. Profiled antenna provides the flaring that varies in radius at each millimeter. Hence, the designing of corrugation in the Profiled antenna is too complicated. The radius at each angle and millimeter is calculated. The complication increases the gain and the output calculation is also a time consuming process. The gain of the conical horn antenna can be improved to 30dB by proper design which linearly increases the complication. The red color in the radiation pattern indicates that the radiation of electric field is higher at that point of angle. Blue color indicates that the electric field is weak in the region. The back lobe has the weakest electric field which is indicated in the waveguide end.

ACKNOWLEDGMENT

The overall analysis of the Smooth Walled Turin, Corrugated Turin, Smooth Walled Potter and Corrugated Potter Conical Horn Antenna indicates that the Potter design with Corrugation produces better results in both gain and directivity. The maximum gain attained using the Potter Corrugation at the Ku Band centered at 15GHz is 21.6GHz. The

application in which the design can be employed is terrestrial communication that performs communication with the antenna in the space.

REFERENCES

- [1] Digisha J. Patel, Dr. A. C. Suthar, "Design of Corrugated Conical Gaussian profiled Horn Antenna for Multi Beam Application", Volume: 03 Issue: 05 May-2016.
- [2] Hassan M. Elkamchouchi, Rateba A. Salem, "Microstrip Patch Antenna with Double I Slot for Wide Band Applications" International Journal of Electronics and Communication Engineering (SSRG - IJECE), Volume 3 Issue 3 2016
- [3] Gurpinder Singh, Deepinder Singh, "Design and Analysis of Conical Horn Antenna for Ku-Band Applications", Volume 3 Issue 7, July 2014.
- [4] R.Anbu, A.Jayakumar, "Design and Analysis of Array Microstrip Patch Antenna with Frequency Reconfiguration", International Journal of Electronics and Communication Engineering (SSRG-IJECE), Volume-4 Issue-4 2017.
- [5] Prashant D. Sachaniya, B.J.Makwana, Maulik Patel, "Design of Conical Corrugated Horn Antenna, Volume 2, Issue 5, May-2015.
- [6] Teniente-Vallinas, J., Gonzalo-García, R., and del-Río-Bocio, C., "Choked-gaussian Corrugated Horn Antenna Design Small Global Coverage Horn Antenna For TT&C With Extremely Low Sidelobe Level".
- [7] Amardeep Gupta, "Networking Protocols for Extraterrestrial Intelligence", International Journal of Computer Science and Engineering (SSRG-IJCSE) – volume 4 Issue 7 – 2017.
- [8] Teniente-Vallinas, J., Gonzalo-García, R., and del-Río-Bocio, C., "Modern Corrugated Horn Antenna Design For Extremely Low Sidelobe Level".
- [9] Tohid Salimi, Amir Maghoul, and Ali A. Abbasid, "Design of a Compact Gaussian Profiled Corrugated Horn Antenna for Low Sidelobe-Level Applications", Vol. 5, No. 2, April 2013.
- [10] Yunus Can Toy, Peyman Mahouti and Filiz, "Design and Manufacturing of an X-Band Horn Antenna using 3-D Printing Technology", 2017.
- [11] S Palani, N.Manikantan, P.Viswanatha Reddy, "Sheltered and Dexterous Data Communication for Team-Based Wireless Antenna Networks" International Journal of Computer Science and Engineering (SSRG-IJCSE), Volume-2 Issue-7 2015.
- [12] Zhongyu Li and Yingying Fan, "A Design of On-chip Terahertz Horn Antenna with Microstrip Feed", 2016.