

# Comprehensive review on Smart Controllers for Switch Reluctance Motor

Mrs. Babitha .S<sup>1</sup>, Mrs.Padmashree V.Kulkarni<sup>2</sup>,Dr. Jyoti Koujalagi<sup>3</sup>,

<sup>1</sup>Associate Professor, Department of ECE, Don Bosco Institute of Technology, Bangalore, India.

<sup>2</sup>Associate Professor, Department of EEE, Don Bosco Institute of Technology, Bangalore, India.

<sup>3</sup>Associate Professor, Department of EEE, Dr.Ambedkar Institute of Technology, Bangalore, India

## Abstract

*Switched reluctance motor promises to be a smart candidate for variable speed applications. To remain competitive, motors will have to be efficient, better connected, more efficient, more flexible and safe. This paper discusses the need of smart direct of switched reluctance for changing industrial landscape. Switched reluctance motor is energy efficient and enables smart motor control solutions. Control system of such a motor has to invariably incorporate functions of sensing the rotor position, phase voltage and current thereby controlling the system parameters in the direction to make operational decisions in an adaptive manner, and perform smart actions. This data should be capable of being accessed and analyzed using sophisticated analytics tools, making the motor control even smarter easily.*

**Index Terms**—Control, Data, Sense, Tools, Variable

## I. INTRODUCTION

This article guides a stepwise walkthrough by Experts for writing a successful journal or a research paper starting from inception of ideas till their publications. Research papers are highly recognized in scholar fraternity and form a core part of PhD curriculum. Research scholars publish their research work in leading journals to complete their grades. In addition, the published research work also provides a big weight-age to get admissions in reputed varsity. Now, here we enlist the proven steps to publish the research paper in a journal.

The switched reluctance motor (SRM) is significant machine which has the capability to produce torque by the nature of the rotor to move onto a position where the inductance of the excited windings is maximized. Torque dip between two subsequent phases excitation dictates the endurance of torque ripple. The higher torque ripple, vibration, and acoustic noise are the major drawback which heavily disturbs the performance capability of SRM during high-speed application.

There are principally two methods for making the torque ripple less. One among them is the technique to make a better magnetic design of motor, while the other is to use sophisticated electronic control techniques [7]. The machine designers are able to lessen the torque pulsations by changing the stator and rotor pole structures, but only at the cost of some specific motor outputs. The electronic approach relies on sharpening the control parameters, such as supply voltage, turn-on and turn-off angles, and current level. The

minimization of torque ripple through electronic control will lead to a decline in the absolute(average) torque, since the motor capabilities are not being fully utilized at all power levels [2]. Those control techniques are broadly divided into linear and nonlinear control techniques. The linear techniques involve traditional controllers Proportional, PI (Proportional Integral), PD (Proportional Derivative) and PID (Proportional Integral Derivative). The nonlinear control techniques are sliding mode, artificial neural network (ANN), fuzzy logic and gain tuning PI controller's infinity controllers, FPGA Based controller [3].This paper give a overview of various linear and nonlinear Smart controllers for SRM and make the understand.

## II. PRODUCTION OF TORQUE RIPPLES

The torque is independent of the direction of the current. Its direction depends only on  $dl/d\theta$ . when the rotor poles are approaching the aligned position torque is positive. When the rotor poles are leaving the aligned position and approaching the unaligned position, the torque is negative. [3].

## III. SRM MODEL DESCRIPTION

Switched Reluctance Motor is a, doubly- salient singly excited motor .This means that it has a sailet poles on both rotor and stator but only one member carries windings.The rotor has no windings,magnets or cage windings. When a stator pole pair is energized by exciting the phase winding, the nearest rotor pole pair is attracted toward the position, where the magnetic path has minimum reluctance [1]. Hence, by energizing the consecutive stator phases in sequence,torque can be developed in either direction of rotation.The SRM Structure is shown in Figure1.

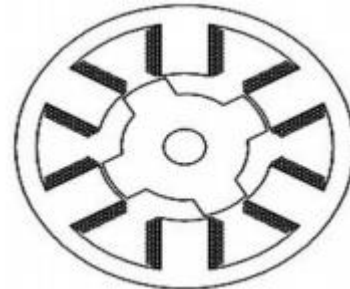

Figure 1 . Structure of 6/4 SRM

**IV. LINEAR CONTROL METHODS FOR SRM**

The basic Sensor Less Operation of the switched Reluctance motor drive is usually tested by conventional controllers under steady state condition. The parameter, speed of the drive is controlled and analyzed with the help of conventional controllers without the need of Position Sensor.

**A. P Controller for SRM**

The variation between the set points and the measured variable will set the manipulated variable in the proportional controller. If the variation is high, the manipulated variable will get affected and it cannot stabilize higher order processes. Large gain is needed for improving the steady state error, when proportional controller is used. If proportional gain is high then the system is said to be unstable else stable. Proportional controller will not eliminate any error, it will just reduce it. The Simulink model is shown in Figure. 2

**B. PI controller for SRM**

The amalgamation of proportional and integral terms is required to refine the speed response and also eliminate the steady state error giving feedback to the converter improves the performance of the PI controller and can eliminate the disturbances present. The forced oscillation and steady state error can be eliminated in PI controller during the operation of P controller and on-off controller respectively

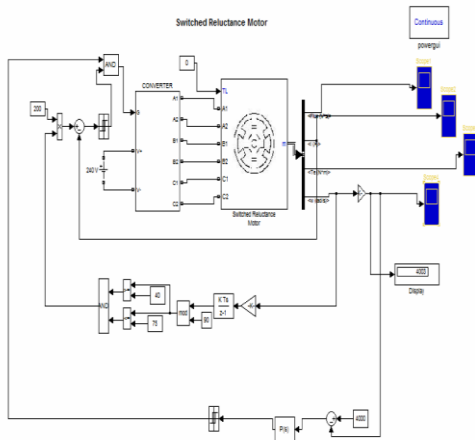

**Figure 2. P Controller for SRM**

Introducing integral mode has a negative effect on stability of the system and its speed response. So that speed response will not increase in PI controller. By introducing derivative mode this problem can be detected. It has the capability to foresee the errors and to decrease the reaction time of the controller. If the speed response is not a criteria normally PI controllers are used. The PI controller is shown in Figure 3

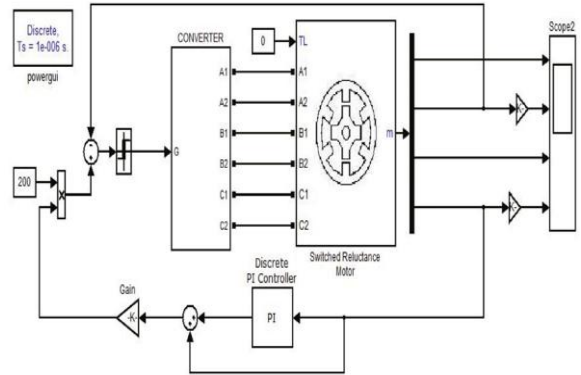

**Figure. 3: PI controller for SRM**

**C. PID Controller for SRM**

The PID controller is heavily used in the control loops of industrial processes but its parameters need to be tuned for a smooth operation. These parameters are dependent of the control process variables that remain unchanged during its regular activity [5]. A derivative control (Kd) has the effect of increasing the stability of the system, thereby reducing the overshoot, and improving the transient response. A PID Controller will improve total response of the system and reduce steady state error which in turn improve the speed performance of SRM. The Simulink model for PID controller is shown in Figure 4

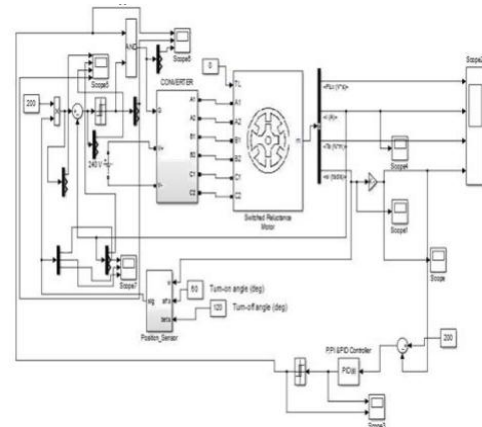

**Figure 4. PID Controller for SRM**

**V. NON LINEAR CONTROL TECHNIQUES FOR SRM**

The nonlinear model incorporates the nonlinearity of magnetization characteristics as well as torque and current profiles. The Results Of Nonlinear Control Techniques gives best performances and high robustness.

**A. Fuzzy Logic Controller**

Fuzzy logic controller is a rule based controller, it consists of an, input, processing and output stages. The aim of it is to control the motor speed and to enhance the speed regulation. The final output of the fuzzy logic controller is used to regulate the switching-on angle of the inverter to regulate the motor shaft speed.

## B. FPGA Based Controller

Real-time simulation of SRM drives on a CPU-based real-time simulator can produce accurate results, but can also have the undesirable effect of causing current overshoots because of model latency. In this case, this latency has prevented the testing of the proposed TDF method in real-time. To remedy this problem, an FPGA implementation is desirable because it offers a very low calculation and I/O latency.

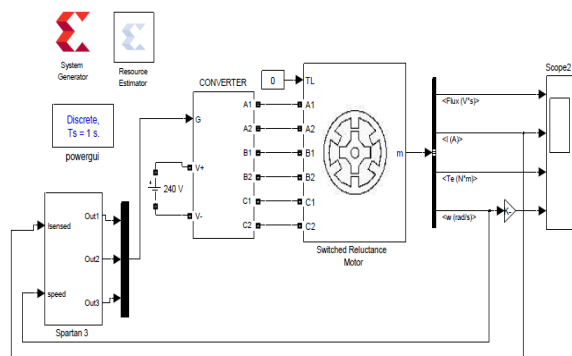

Figure 5. FPGA Controller For SRM

## VI. CONCLUSION

In this Paper a comprehensive study of linear and nonlinear control techniques for SRM is provided. It also discusses the Principle of working of and SRM. Simulation models for these techniques have been presented.

## REFERENCES

- [1] H-infinity robust control technique for controlling the speed of switched reluctance motor A. Rajendran, s. Padma  
Front. Electr.Electron. Eng. 2012, 7(3): 337–346 DOI 10.1007/s11460-012-0204-0
- [2] Speed Control of Switched Reluctance Motor (SRM) Ashwani Soni<sup>1</sup>, Abhishek Garg<sup>2</sup>, Pramod<sup>3</sup>, Lave Gupta<sup>4</sup>, Abhilasha Rani Goyal International Journal of Emerging Technology and Advanced Engineering Volume 4, Issue 10, October 2014
- [3] Switched Reluctance Generator - Modeling, Design, Simulation, Analysis and Control A Comprehensive Review D.Susitra, E.Annie Elisabeth Jebaseeli 2010 International Journal of Computer Applications (0975 – 8887) Volume 1 – No. 2
- [4] Torque Ripple Minimization of a Switched Reluctance Motor using Fuzzy Logic Control, International Journal on Recent and Innovation Trends in Computing and Communication ISSN: 2321-8169 Volume: 3
- [5] R. Krishnan, Switched Reluctance Motor Drives, CRC Press LLC, 2001.
- [6] Kamala Kannan C, Paranjothi S R, Paramasivam S. Optimal control of switched reluctance motor using tuned fuzzy logic control. European Journal of Scientific Research, 2011, 55(3): 436–443
- [7] T.J.E. Miller, Switched Reluctance Motors and Their Control, Magna Physics, Oxford, 1992.