

# Smart Starter using Agriculture

S.Arunkumar<sup>1</sup>, D.Ajithkumar<sup>2</sup>, M.Vidhyasri<sup>3</sup>, Mr.N.Jegan<sup>4</sup>

<sup>1,2,3</sup> Under Graduate Student, <sup>4</sup> Assistant Professor

Department of Electrical Engineering

Selvam college of Technology, Namakkal, TamilNadu, India,

## Abstract

*In this project, a circuit is proposed to utilize the two phase to three phase converter available already. This is circuit is designed with relay logic only. It makes the circuit simple and low cost. A two to three phase converter used to run the induction motor during any one phase failure. To run the motor to deliver the same output without affecting other performance a two to three phase converter used. In which, a capacitor used to supply the power to the leg where power supply absent. If more than one induction motor run at different time, the same two to three phase converter can be used to run all the motors by sharing. It avoids additional expenditure. So it is economically recommended.*

*The control circuit designed without help of micro controller makes the system very simple and low cost. It effectively share the available two to three phase converter to run all the induction motor at different time and avoids simultaneous operation and gives the protection against any malfunction. The proposed concept is evaluated with the use of three induction motor.*

## I. INTRODUCTION

Present day troubles move in sizes, kind of helpfulness, extent of action, nature of condition, et cetera. The sort of motors used varies as indicated by the application. Guideline Mill motors, right hand motors, pump motors, roller table or transport motors, crane motors, high precision position controlled motors, et cetera., may be recognized using synchronous motors, acknowledgment motors, standard brushed DC motors and interminable magnet brushless DC motors. shows unmistakable sorts of mechanical applications, wherein diverse motors are used.

The extensive number of sorts of motors used as a piece of mechanical applications, the acknowledgment machines (IM) are the most comprehensively used due to their clear yet extreme advancement and simplicity. The squirrel bind design is the typically used kind of IMs because of the essential improvement of the rotor winding, which makes them solid and requires low help. The squirrel restrict acknowledgment machines are definitely not hard to

manufacture when appeared differently in relation to the damage rotor make. Therefore, the normal squirrel restrict IMs are generally supported by the makers and the end-customers for a few applications.

### A. Multi-Motor Load Sharing

A few applications require different engines to work pair or in parallel. The explanations behind utilizing various engines may fluctuate from absence of room for enormous engines bringing about the utilization of a few coupled engines of littler appraisals pair, to process prerequisite of parallel engines. Process, for example, Mills, transport lines, roller tables, cranes, and so on., can't work with only one engine. They require in excess of one engine working in parallel to drive the regular mechanical load. In such applications, stack sharing is normally required, and it is essential to keep up the speed and the torque of the partaking engines the same or in some extent as required by the procedure. Load sharing is basically a plan where a typical load is shared by various engine drive sets. There are diverse conceivable setups accessible for the driving the heap sharing engines. Figure 1.1 shows two such unique plans in multi-engine applications. In a different engine drive set (engines driven by individual devoted drive) is utilized to share the heap. In numerous engines driven by single VFD are utilized; henceforth singular control of the engines isn't conceivable and the heap sharing happens normally and wild. In any case, in Figure 1.1, it is seen that the engines can be exclusively controlled by the relating VFDs. Thus, just the design of Figure 1.1, can be utilized for successful re-dispersion of the heap among the engines and accomplishing powerful load sharing under different unsettling influences. Subsequently, this setup is considered in this postulation. various engines may fluctuate from absence of room for enormous engines bringing about the utilization of a few coupled engines of littler appraisals pair, to process prerequisite of parallel engines. Process, for example, Mills.



**Figure 1.1 Load sharing motor test bench used for the practical observations.**

The survey schematic of the test situate is outlined in Figure 1.1. In the considered motor seat with three machines showed up in detail in Figure 1.1, two IMs assessed 1HP and evaluated 5HP were coupled on a run of the mill shaft and thought to drive a regular mechanical load duplicated by the remaining third motor. The proposed scheme is realized by using one of the motors, Motor 3 (1HP), as a load and interchange motors (Motor 1 (1HP) and Motor 2 (5HP)) for driving this store. As two indistinct motors with different rotor securities were not available, we used two dissimilar motors, 1HP and evaluated 5HP, for the investigation. These motors are powered using VFDs which are continue running in V/F control. The particulars of the VFDs used as a piece of the set-up are dense in the Appendix B. The PLC is used to impersonate the control as illuminated in the past regions. In the pondered configuration, Motor 1 (1HP) and Motor 2 (5HP) are speed referenced with 1507.3 rpm threatening to clockwise bearing; while the Motor 3 (1HP) is torque referenced to continue running at 100% stacking clockwise to mirror a regular mechanical load of 4.05 N.m . The plenitude imperativeness from Motor 3 (1HP) is being dumped through the VFD 3 into a right hand breaking resistor box.

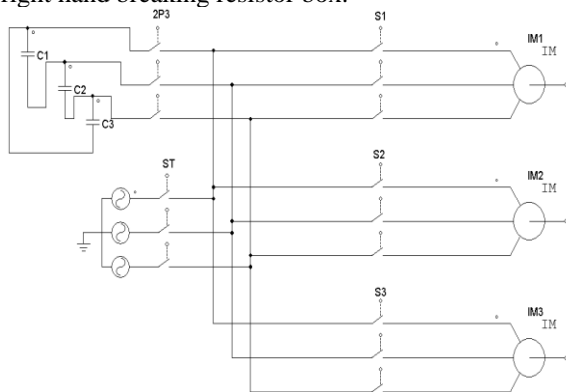

**Figure 1.2 VFD's used for powering the load sharing motors.**

Such deviations may result in disproportionate sharing of the mechanical load and even overloading one or several machines while some machines may be under-loaded. The basic low-cost variable frequency drives (VFDs) with traditional open-loop V/F control scheme fail to share the load under such conditions. In this Thesis, two new methods are proposed to address the load sharing problems under an internal disturbances (such as rotor resistance variations) and external disturbances (such as wheel slippage due to snow/water/oil etc.). The new methods are shown to be The effective in sharing the load under disturbances. Moreover, the proposed methodologies may be readily extended to an arbitrary number of motors driving a common mechanical load, and are easy to implement with traditional/existing low-cost VFDs, which may be advantageous for many existing or legacy applications.

### B. Circuit diagram



**Figure:1.3 circuit diagram**

### C. Variable Frequency Drives in Industrial Applications

The IM all alone is hard to control under the settled recurrence source. The relentless state torque-speed trademark is extremely nonlinear over the whole speed district and is ordinarily usable just in the locale near the synchronous speed. Thus, an IM can't be utilized alone in numerous mechanical applications which require extensive variety of controlled movement. A few basic power-electronic-based control frameworks are utilized in industry to control the task of acceptance machines. The variable recurrence drives (VFDs) give the most proficient and powerful method for engine control. The point of control is typically mechanical speed or yield torque of the machine. The VFDs can extend from cutting edge vector-controlled plans wherein the torque control might be accomplished promptly, to the customary Volts-per- Hertz (V/F) scalar control which depends on unflinching state torque-speed relationship of the machine to convey the

required speed or torque, which may likewise be utilized either in open-circle or in a shut circle with speed controller.

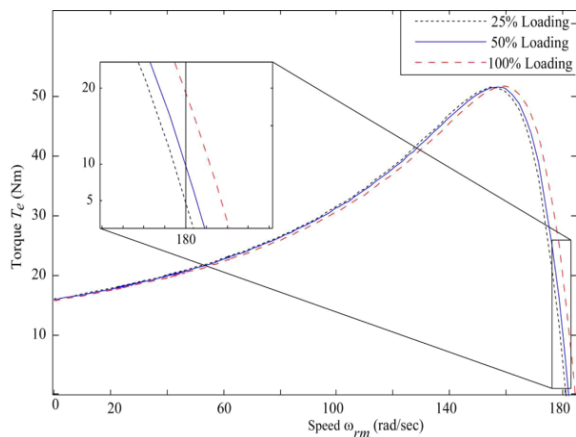

Figure 2.1 Torque Speed Characteristics

## II. CONCLUSION

In this thesis, two practical cases of load sharing in systems with the multiple induction motor drives where studied and their solutions were discussed in detail. The provided solutions have the element of novelty, are simple and cost-effective to implement considering the same existing basic equipment and V/F VFDs, which may be appealing to many industrial applications.

## REFERENCES

- [1] Danieli. Danieli Centro Combustion. [Online]. <http://www.danieli.com>
- [2] Eastport Trading Co., Inc. Rolling Mill Rolls & Spares. [Online]. <http://www.eastporttrading.com/>
- [3] Dr.G.Rajanbabu,"Computerized Agriculture & Farm Management System "International Journal of Agriculture & Environmental Science (SSRG-IJAES),Volume 1 Issue1,2014.
- [4] Danieli. Danieli Wean United. [Online]. <http://www.danieli.com/>
- [5] ThyssenKruppSteel USA. ThyssenKrupp Construction. [Online]. <http://www.thyssenkruppsteelusa.com/>
- [6] Rockwell Automation, "Rockwell Automation-Load Sharing Applications for AC Drive," DRIVES-WP001A-EN-P, June 2006.
- [7] Rockwell Automation, "Allen Bradley: PowerFlex 700 AC Drives Technical Data," 20B-TD001F-EN-P, July 2009.
- [8] Neeraj Bhaskar Wadekar, Prashant Kailash Sharma, Nilesh Sanjay Sapkale,"Detection and Controlling of Grape Leaf Diseases using Image Processing and Embedded System",International Journal of Electrical and Electronics Engineering (SSRG-IJEEE) ,Volume-2 Issue-10 2015.
- [9] ABB, Direct torque control - the world's most advanced the world's most advanced, 2001, 3AFE58056685 REV C 6.6.2011.
- [10] N. Mitrovic, V. Kostic, M. Petronijevic, and B. Jefcenic, "Multi-Motor Drives for Crane Application," Advances in Electrical and Computer Engineering, vol. 9, no. 3, pp. 57 - 62, October 2009.
- [11] The MathWorks, Inc. (2006) SimPower Systems: Model and simulate electrical power systems User's Guide. [Online]. [www.mathworks.com](http://www.mathworks.com)
- [12] [10] Plexim GmbH. Piecewise Linear Electrical Circuit Simulation (PLECS) User manual. [Online]. [www.plexim.com](http://www.plexim.com)