

# Integrating Renewable Energy System in Smart Grid applications

<sup>1</sup>D.Bharathy Priya , <sup>2</sup>Dr.A.Sumathi

<sup>1</sup>Research Scholar, Affiliation of Anna University: Faculty of Electrical Engineering

<sup>2</sup>HOD, Department of Electronics and Communication Engineering ,Affiliation of Anna University

<sup>1,2</sup>Adhiyamaan College of Engineering, Dr.M.G.R.Nagar , Hosur, Tamilnadu,India

**Abstract** — Smart Grid is an electrical Grid that communicate with us to manage our electricity consumption by creating network of communications that will control computers automation. In Smart Grid applications, Solar and Wind energy production play an important role in Integrating Renewable Energy resources. Smart Grid technology enables by adding Sensors and Software's to the existing system that gives utilities and individual information to help them understand and react to changes quickly.

**Keywords** — Renewable Energy sources, Smart Grid, PV

## I. INTRODUCTION

Smart grid is to promote active consumer participation and decision making as well as to create the operation environment in which both utilities and electricity users influence each other. Integrating modern digital electronics technology into the electrical power grid enables the utility to detect, monitor and respond digitally to any changes, thus making it a smarter version of the grid.

### A. Need for Integrating Renewable Energy Sources

- Advanced sensing systems, communicating and controlling method functionalities in the power grid's operation, for the purpose of enhanced efficiency, reliability, security and reduces emission.
- Reduce barriers in integrating renewable energy resources.
- Power grids allows to support a greater percentage of variable renewable energy resources.
- More effectively and low cost.
- As integrating renewable energy system increases, more advanced control system will be required to maintain reliability.

### B. Benefits of Integrating Renewable energy sources

Smart grid technology helps to Integrate both small and large facilities. Renewable Generation will reduces the need for investments in grid reinforcement infrastructure, that will controls and operational metrics. Distribution level facilities provide energy security to limit the extent of a system disturbance and allow for faster recovery. grid technologies such as Advanced Meter Infrastructure, Advanced Electricity Pricing, Demand Response and Distribution Automation Resource Forecasting, Smart Inverters, Distributed storage, , Bulk

power Technologies, also allow diverse and changing mix of Renewable energy system on the grid.[1]

## II. SMART GRID RENEWABLE ENERGY SOURCES

Renewable energy resources and distributed generation systems are receiving support and their shares in generating electricity are rapidly rising. Lots of sensors and controls are used to re-route power to other power lines that is required from renewable energy resources, so that power can be transported to a greater distance whenever it is needed. Smart grid delivers electricity from suppliers to consumers using digital technology through control automation continuous monitoring and optimization of distribution system in order to save energy, reduces consumer cost and improve reliability. Smart Grid technology is to provide flexibility that need to integrate variable generation in characteristics of renewable resources such as Wind or Photovoltaic.

### A. PV Smart Grid System

The Integration of systems into the electrical power grid with several technical problems like instability, energy quality degradation, signal parameter fluctuation and mismatch between loan supply and demand, Integrating decentralized renewable energy generators in co-generation seems to be the backing solution for the above stated problem.

Interleaved Dc-DC converter reduce the ripples in PV current without requirements of sizable or high switching frequency. The DC voltage on the inverter side of the DC-DC converter is normally maintained to be constant by the inverter control. The MPPT algorithm is used to find continually a PV array DC voltage which extracts the most power from the PV array while the cell temperatures and operating conditions of the module change. In P&O method, the terminal voltage of the PV array is perturbed in one direction and if the power from the PV array increases, then the operating voltage is further perturbed in the same direction. Filter is placed at the output to minimize harmonics fed into the power system. In some designs a transformer is also employed at the output of the inverter to ensure no DC is injected into the grid.

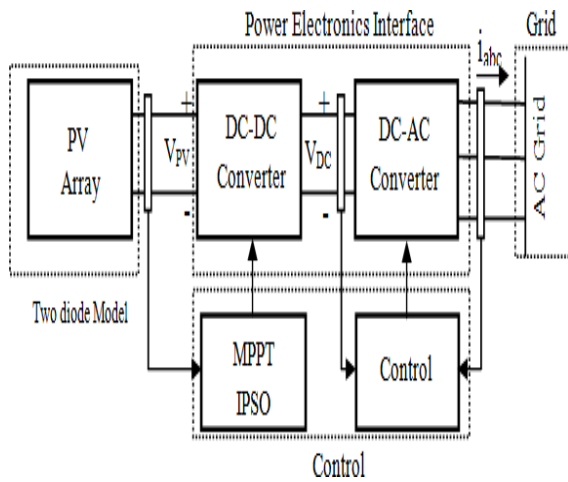

Fig 1: Block Diagram of Solar PV Grid System

### B. Smart Grid Functionalities

The main functionalities of Smart Grid in Renewable energy systems are

- Low cost reliable and quality with energy supply that can be archived through peak demand management, demand response control (with smart meters/AMI) and solar roof tops.- From the consumer perspective of view
- Customer satisfaction with a margin of profit for continuous improvement of services for uninterrupted and secured energy delivery, that can be achieved by reducing energy losses, improving metering, billing and collection (MBC), outage reduction, efficiently using the asset (with AMI/DMS/OMS and IT Systems)- From the Distribution perspective of view.
- Reliable and quality and secured generation and transmission to end customers through /Service

Providers, that can be achieved using efficient energy dispatch systems, mix of generation (conventional and renewable)(SCADA/EMS, WAMPAC/, IT system)- From the Transmission and Generating companies perspectives of view.

### C. Features of a Smart Grid Technology

Figure 2 shows the key features of Smart Grid Technology. The key options of Grid technology are as follows:

- ✓ Enables participation by shoppers.
- ✓ Enables new product list, services and markets.
- ✓ Anticipates and responds to system disturbances in an exceedingly self -correcting manner.
- ✓ Operates resiliently against physical and -attack and natural.
- ✓ Provides power quality that meets a range of needs required by our new digital economy.
- ✓ Accommodating all generation and storage Integrating systems, monitoring merging, controlling, protection, maintenance, EMS, AMI

- etc.
- ✓ Having Plug-in and Play system features for work equipment and ICT based solutions.

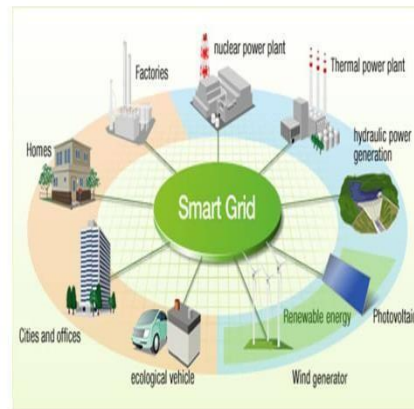

Fig 2: Smart Grid Technology Features

### III. LITERATURE SURVEY

Survey of integrating renewable energy system in smart grid application based on the characteristics as follows: merits and demerits of smart grid concept methods, optimization of renewable energy in smart grid system, pricing and forecasting strategy are as follows:

- ✓ In this paper, discussed about smart grid concept and applications with respect to designing, size and optimal placement of the energy mix, small scale test implementations in order to choose the best strategy to its implementation, voltage stability, overall system integration rate, global losses and many other factors which help economical and technical [7].
- ✓ Discussed key features of the smart grid by performing the smart demand response dispatching, survey of potentials and benefits when enabling technologies such as energy controllers, smart meters and communication systems. Implicitly promotes the reliability and sustainability of the power supply and lowering the peak demand.[5].
- ✓ Discussed solutions of the connection and the integration of renewable energy sources in the electric grid and their architectures.[3]
- ✓ Discussed the tools that are available for PV system design and sizing, problem arising from the system sizing and PV contribution to the load [13], [14].
- ✓ Discussed that the renewable energy sources provide reliable and comparatively low cost electricity services[9]
- ✓ Discussed about the allocation of renewable energy sources in smart grid system and optimal reactive power injection in order to improve the voltage stability of the system and the penetration level of renewable energy sources.[10]

- ✓ smart grid application for renewable energy distributed generation, merits and demerits of renewable energy distributed generation is discussed in this paper.[12]
- ✓ Modeling of PV system, controller method used in PV and simulation of grid connected solar system is discussed in this paper [2].
- ✓ Discussed the issues of renewable energy sources from engineering's, energy supply and related environmental problems like global warming, health and economic perspectives [6].
- ✓ Improved power grid systems such as smart infrastructure system, the smart management system, and the smart protection system are discussed in this paper [8].

Table 1 shows the comparison between Conventional Grid and Smart Grid technology of renewable energy sources in PV system on the basis of some key Features.

Table 1: Comparison between Conventional Grid and Smart Grid.

Comparison	Conventional Grid	Smart Grid
Information Flow	Unidirectional	Bidirectional
Electricity Generation	Central Generation	Distributed Generation
Grid topology	Radial	Network
Monitoring ability	usually blind	self-monitoring
Sensors	Few	Many
Environmental pollution	High	Low
Overall Efficiency	Low	High
Communication	one way and local two way communication	limited Global/integrated two way communication.
Control system	Limited	Pervasive
Reliability	Estimated	Predictive
Control	Lack of control	Robust control technology
Operation and Maintenance	Manual equipment checks, time based maintenance	Remote monitoring, predictive condition based maintenance.

#### IV. CONCLUSION

This paper discussed, the key role of smart grid technology in renewable energy system which has a demanding and role in the future efficient power generation and distribution. Integrating renewable energy sources is expected to be significant influence on the operation of the power system for sustainable energy in future work that involves- Distributed renewable interconnection technologies with advanced practicality, Integrating of renewable energy sources with load and storage, Electric power system technologies, controls and operations that enable high penetration of distributing renewable energy sources, models for renewable energy systems that allow them to be included in various planning and analysis tools.

#### REFERENCES

- [1] Ministry of New and Renewable Energy [2016], Annual Report 2016- 2017, NewDelhi of New and Renewable Energy.
- [2] Ben , I., M., N., .., "Modeling, control and simulation of a grid connected PV system", IEEE 2014 International conference on Electrical sciences and Technologies in Maghreb (CISTEM)April 2015.
- [3] Y.V. , RavikumarBhimasingua "Key aspects of smart grid design for distribution Automation: Architecture and Responsibilities", , Smart Grid Technologies, Vol 21, pp.352-359, 2015
- [4] J., J.A., M.A., A. "Analysis of massive integration of renewable power plants under new regulatory frameworks", IEEE conference on Renewable energy research and application (ICRERA), October 2015
- [5] PierluigiSiano, "Demand response and smart grids-A " , Renewable and Sustainable energy reviews, vol 30, pp 461-478, 2014
- [6] Abbas , SuardiSuhaimi, GholamrezaZahed, AlirezaBahadori, "A review on the drawbacks of renewable energy as a promising energy source of the future", IEEE power and energy magazine 38, issue 2, pp 317-3282013.
- [7] N., S., " Opportunities and challenges of integrating Renewable energy in Smart Grid System", energy , Vol.34, pp 282-290, 2013
- [8] Xi fang, SaptajayantMisra, GuoliangXue, yang, " The New and improved power Grid: A " , IEEE communications and Tutorials, Vol 14, No.4. 944-980, 2012.
- [9] V, S, G, MG, F, E, G. Smart renewable generation for an system. Technical and economic issues of future scenarios. Energy 2012;39(1):196- 204
- [10] M H, Alvarez-Ortega C. Integration of renewable energy sources in smart grids by means of evolutionary optimization algorithms. Systems with Applications 2012;39 (5):5513-22
- [11] Steve G. , Kelly Crandall, "chapter 1-Smart grid is a lot more than just technology", science direct, smart Grid, integrating Renewable, Distributed and efficient energy, pp3-28, November 2012.
- [12] A, Weber K,Challenges and Integration of PV and Wind Energy Facilities from a smart Grid point of view. 2012;25;118-25
- [13] A, T. Stand-alone PV system design: Results using a new sizing approach. Renewable Energy 2008;33(1):162-7
- [14] R, Lopez R, Approaches for developing a sizing method for stand-alone PV systems with variable demand. Renewable Energy 2008;33(5):1037-48
- [15] Mohamed, O. Mohammed and G. Roig, Efficient Integration of Renewable Energy to Smart Grid Power Systems, Tenth LACCEI Latin American and Caribbean Conference (LACCEI'2012) pp. 1-6.
- [16] R. Hidalgo, C. Abbey and G. Joos,Integrating Distributed

- Generation with Smart Grid Enabling Technologies, Innovative Smart Grid Technologies (ISGT Latin America), IEEE PES Conference (2011) pp. 1-7.
- [17] E. Natsheh, A. Albarbar and J. Yazdani, Modeling and Control for Smart Grid Integration of Solar /Wind Energy Conversion System, Innovative Smart Grid Technologies (ISGT Europe), 2nd IEEE PES International Conference and Exhibition (2011) pp. 1-8.
- [18] J. M. Carrasco, Power Electronics for the Integration of Renewable Energies into Smart Grids, Power Engineering, Energy and Electrical Drives (POWERENG), International Conference (2011) 1.
- [19] H. YuPin, Y. HongTzer, W. Chung Chi and C. JiannFuh, Implementation of a New High Step-up Dc-Dc Converter for Applications in Renewable Energy Conversion of a Smart Grid, Advanced Power System Automation and Protection (APAP), International Conference (2011) pp.2140-2149.
- [20] A. Kiani and A. Annaswamy, Distributed Hierarchical Control for Renewable Energy Integration in a Smart Grid, Innovative Smart Grid Technologies (ISGT), IEEE PES (2012) pp. 1-8
- [21] E. Bitar, P. P. Khargonekar and K. Poolla, Systems and Control Opportunities in the Integration of Renewable Energy into the Smart Grid, Proc. of IFAC World Congress (2011) pp. 4927-4932
- [22] L. H. Koh, Y. K. Tan, P. Wang and K. J. Tseng, Renewable Energy Integration into Smart Grids: Problems and Solutions— Singapore Experience, Power and Energy Society General Meeting, IEEE (2012) pp.1-7