

Design and Fabrication of Automatic Dishwasher Machine

R.B.Venkatesh

UG Scholar: Department of Mechanical Engineering, K.L.N. College of Engineering,
Pottapalayam-630612, India

V.SivaramKumar

Associate Professor: Department of Mechanical Engineering, K.L.N. College of Engineering
Pottapalayam-630612, India

Abstract—Though lot of human activities are automated in the present competitive world. There is a lag in automated dish washer. Some machines are already designed with the help of high velocity water only; hence there is a chance of uncleanliness and not removing tough strains in dishes. In order to overcome the above problems a special machine called “Automatic Dishwasher Machine” with rollers, brush and water jet introduced in this work. By combining dishwasher with roller mechanism using brush and water jet, it is possible to clean the objects effectively than the other machines and without any man power.

I. INTRODUCTION

A dishwasher is a mechanical device for cleaning eating-utensils and dishes. Dishwashers can be found in private homes and hotels. Unlike manual dishwashing's, which depend largely on physical scrubbing to remove soiling, the mechanical dishwasher cleans by the brush and by spraying water, at the dishes. A mix of water and detergent is circulated by a pump. Water is pumped to one or more rotating sprays arms, which blast the dishes with the cleaning mixture. Once the wash is finished, the water is drained. After the rinse cycle finishes and the water is drained, and the dishes are left in the atmosphere for drying.

The function of the dishwasher is to provide the mechanical action necessary to distribute and direct the detergent solution and rinse waters over, under and around the dishes to loosen and remove soil. The dishwasher must also remove soil-laden waters from the machine after

Each phase of the cycle and provide for the drying of dishes after the cleaning process has been completed

A.EXISTING DISHWASHER LAYOUT

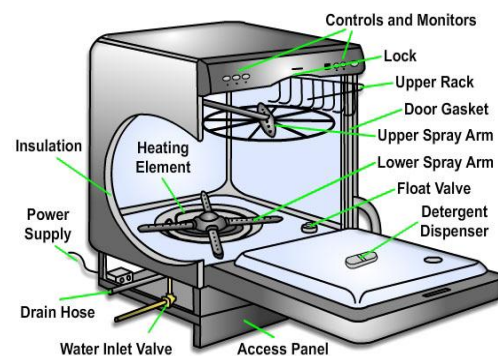

Fig. 1 Existing Dishwasher Layout

Automatic dishwashers vary in the design of their washing systems. Some have a single water source; others may have several water sources. Water is distributed in dishwashers by spray arms or spray towers. The design of the spray arms or towers may differ in size, shape and placement in the dishwasher, or in the number, size and location of their water ports (holes through which water is forced). All of the washing systems do a good job, but those with fewer water sources require greater care in loading the dishes to prevent blocking the washing action to various parts of the machine, especially the corners. The total volume of water used in a complete cycle can vary from 6 - 10 gallons, depending on the number of washes and rinses included in that particular cycle.

II. LITERATURE SURVEY

Various cleaning procedures are reported in the literature. The simplest one involved rinsing /brushing of dish using water which significantly removed a high level of bacteria (Miller et al., 1996). Interestingly, use of chemical cleaners did not statistically improve the performance. Similarly, Abrishami (1994) reported the use of an automatic dishwasher with only cold water to remove bacterial contamination from a dish. Being the most easily

cleaned. Mr. Cochrane, in 1917 has introduced an electrical motor to operate the centrifugal water pump. In this solution she also introduced the spraying arms. In that model, the rinse phase was also introduced; the introduction of electrical appliances in this modern life kitchen has determined the born of new era and the dishwasher manufactures have seen a speedy increase of the production volume for this appliance. In paper "An Automatically Controlled Dishwashing Machine" written by "Wesley C.Cox" they conclude that in order to improve the Dishwashing process without human efforts and the removal of any bacteria which may remain by rising with clear water. The essential step in washing of eating utensils are the removal of all soil by washing of eating utensils are the removal of all soil by washing for the optimum length of time with water in which a suitable detergent has been added in proper concentration. In paper "Field Studies on TWO and Three Compartment Sink Manual Dishwashing" written by Morris. They observed that improper cleaned and sanitizes dishes constitute a health hazard.

Surveying the existing dishwashing machines in the market we observed many defects in the system such as wastage of water, requirement of man power, high installation cost, poor quality of cleaning etc. Hence, we decided to implement a dishwashing machine which will not only overcome these defects but also provide optimized cleaning. So for efficient cleaning of dishes we can use this system. In future by modifying this system we can clean the big utensils, glassware, etc.

III.COMPONENTS USED

A. Roller with Brush

This is the main component of this machine. Roller Brushes are made as per the specification given by the customer. The overall diameter and length can be varied. The brush can be offered with or without shaft. Application areas are truly vast.

These brushes are hard and attached to the wooden roller, where there is a hollow space in the wooden layer.

B. Belt Drive

- A mechanism in which power is transmitted by the movement of a continuous flexible belt.
- A belt is a looped strip of flexible material, used to mechanically link two or more rotating shafts.
- They may be used as a source of motion, to efficiently transmit power, or to track relative movement. Belts are looped over pulleys.

Types of Belts

- Flat Belt

- V-Belt
- Cross Belt
- Timing Belt
- Round Belt

In our project we use only two types of belt. (i.e.) Flat Belt and V-Belt

C. Pulley

A pulley is a wheel on a shaft that is designed to support movement and change of direction of a taut cable or belt along its circumference. Pulleys are used in a variety of ways to lift loads, apply forces, and to transmit power.

D. Shaft

Several small bits of shafts are used. Mild steel of about 20mm diameter are polished well using abrasive clothes. Eight shafts are length of 100mm is used and they are turned and stepped by holding it in a centre lathe. The steel shaft of one end is connected with the Roller and another end is fitted with pulley. It helps to rotate the roller brush easily and smoothly.

E. Sheet Metal

Sheet metal is metal formed by an industrial process into thin, flat pieces. It is one of the fundamental forms used in metalworking and it can be cut and bent into a variety of shapes. Countless everyday objects are constructed with sheet metal.

F. Bearing and its Function

A ball bearing is a type of rolling element bearing that uses balls to maintain the separation between the bearing races. The purpose of a ball bearing is to reduce rotational friction and support radial and axial loads. It achieves this by using at least two races to contain the balls and transmit the loads through the balls.

In most applications, one race is stationary and the other is attached to the rotating assembly e.g., a hub or a shaft. As one of the bearing races rotates it causes the balls to rotate as well. Because the balls are rolling, they have a much lower coefficient of friction than if two flat surfaces were sliding against each other.

Ball bearings support rotary parts and reduce friction to facilitate the smooth operation of machines

G. Motor and Principle

A **DC motor** is any of a class of electrical machines that converts direct current electrical power into mechanical power. The most common types rely on the forces produced by magnetic fields. Nearly all types of DC motors have some internal mechanism, either electromechanical or electronic; to periodically

change the direction of current flow in part of the motor. Most types produce rotary motion; a linear motor directly produces force and motion in a straight line.

DC motors were the first type widely used, since they could be powered from existing direct-current lighting power distribution systems. A DC motor's speed can be controlled over a wide range, using either a variable supply voltage or by changing the strength of current in its field windings. Small DC motors are used in tools, toys, and appliances. The advent of power electronics has made replacement of DC motors with AC motors possible in many applications.

An electric motor is an electric machine that converts electrical energy into mechanical energy. An Electric DC motor is a machine which converts electric energy into mechanical energy. The working of DC motor is based on the principle that when a current-carrying conductor is placed in a magnetic field, it experiences a mechanical force. The direction of mechanical force is given by Fleming's Left-hand Rule and its magnitude is given by

$F = BIl$ Newton. The reason is that speed/torque characteristics of D.C. motors are much more superior to that of AC. motors.

IV. WORKING OF PROPOSED DISHWASHER

Auto dishwashing machine is a kind of mechanical machine widely used for cleaning eating-utensils and dishes in private homes and hotels to eliminate the job of hand washing. Especially have higher efficiencies than other types of manual dishwashing (which depend largely on physical scrubbing to remove soiling). The dishwashers are connected to the kitchen sinks for water supply. This mechanical dishwasher cleans by the brush and by spraying water several times, at the dishes. A mix of water and detergent is sprayed at the plates. After the rinse cycle finishes and the water is drained, and the dishes are left in the atmosphere for drying.

First, the plate to be cleaned is feeded into the mouth of mica panel. Once the dish is feeded, the roller will pull the dish automatically and the detergent added with a soapy water mixture which is ready to clean the dish is then forced to pass through the spray arms which spray high pressure water to clean the incoming plate. After the first cleaning, the water mixture falls again into the basin which is pumped back on the dishes for the second cycle. After the washing the waste water is removed. The fresh water cleans the dishes for few minutes and they are now ready for drying.

H. Construction

In this Automatic Dishwasher Machine, the shaft is fitted into the roller on either side. The sheet metal is drilled to the size equal to the diameter of shaft . With the aid of welding the bearing is placed in the sheet metal where the drilling has been done. The shaft is supported with the help of bearing to reduce friction and helps it spin very smoothly. But it also means that there is not very much contact area holding that load. Since the load is relatively small it can easily handle radial thrust. The pulley (a simple machine that has many complex uses) is fitted at the end of the shaft. The common user is to create motion transfer with the least amount of effort; it has a groove around its circumference.

Here the drive element used is a DC motor. A pulley is also fixed in the shaft of the motor. The drive element of a pulley used in the system is belt that runs over the pulley inside the groove. The power to the drive is given through the adaptor from the main.

I. Advantages

- Very useful in reducing human effort.
- More number of dishes can be washed in very short time.
- Better utilization of water.

J. Limitations

- The filler basket needs regular cleaning to avoid rotten odor in the kitchen.
- A clogging in the drain pipe due to the left over foods or other materials will result in slow drain of the dishwasher.
- Another common failure of the dishwasher is caused due to the clogging in the holes of the dishwasher arms. The water is sprayed unevenly which results in poor washing.

K. Application

- It is used in large scale kitchens such as hotels, restaurants etc., where there is requirement of more number of dishes.

V.3D DIAGRAM OF PROPOSED DISHWASHER

For the parts are sketched neatly as per I.S.I. code after determining their dimension. It helps to have a clear idea about the parts while machining them with no doubt. The Fig. 3 assembly drawing has a major role in assembling and understanding the project. And also Fig. 2 Part diagrams show the various parts which are used in this project.

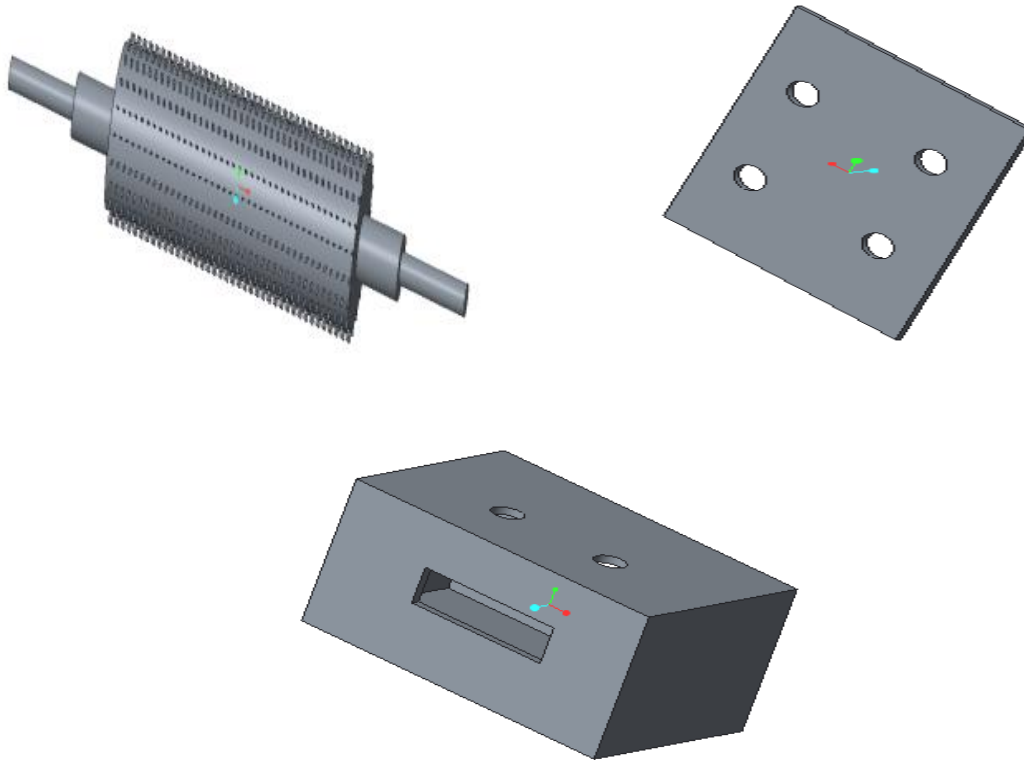

Fig.2 Part Diagrams

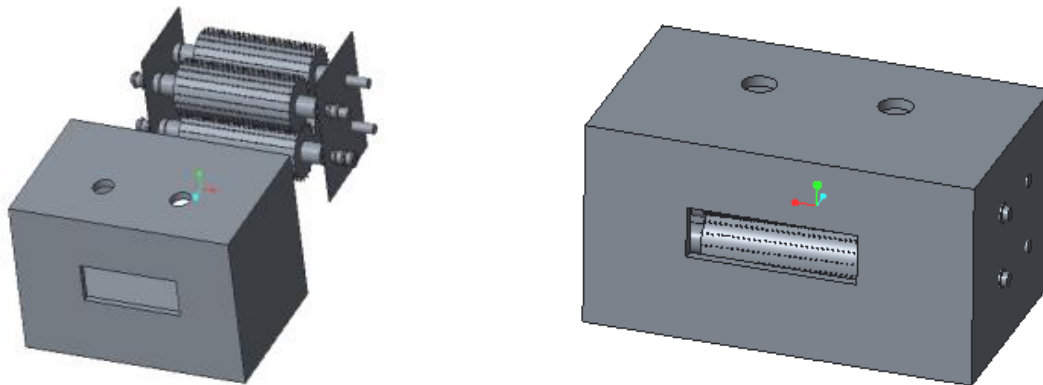

Fig. 3 Assembly Diagrams

VI. DESIGN CALCULATION

In this project, it must to calculate for belt design which is used to run the fabricated model.

The following steps were used to calculate for Belt Drive.

A. DESIGN PROCEDURE FOR BELT

Rated Power=100w

Diameters of pulley = 20mm

Speed of the driving pulley =100rpm

Centre distance = 130mm

STEP 1: In this step selecting the type of belt which was required to run It.:

The drive is OPEN FLAT BELT DRIVE, CROSS BELT

STEP 2: In this step first to know the diameter of driven and driving Pulleys. And find the value of ratio 'i'.

By using PSG Data Book equation 1 is used to find the 'i' value, Where d_2 -Diameter of pulley 2 & d_1 -Diameter of pulley 1. N_1 -Speed of pulley 1 in rpm & N_2 -Speed of pulley 2 in rpm

If we have any three values we can easily find the value by using this equation 1.

But we have to calculate only Ratio of 'i'.

$$d_1 = d_2 = 20\text{mm}$$

$$i = N_1/N_2 = d_2/d_1 \quad \dots(1)$$

$$i = 20/20$$

$$i = 1$$

STEP 3: In this step we calculate the Power which will be calculated using PSG Data Book.

Design power=Rated power kW×Load correction/Correction factor (F_a)

Load correction factor $F_a = 1.2$

Equation 2 is used to find the arc of contact. Where 'C' is the Pulley Centre distance.

$$\text{Arc of contact} = 180 - ((d_1 - d_2)/C) \quad \dots(2)$$

$$= 180 - ((20 - 20)/0.130)$$

$$= 180$$

Correction factor $F_d = 1$

For arc of contact 180

$$\text{Design power} = 0.10 \times 1.2$$

$$= 0.12\text{w}$$

STEP 4: To find the Belt Width and velocity of Belt by equation 3. From PSG Data Book,

Width (b) = Design power / Load rating × No of plies

Load rating,

Load rating at v m/s = load rating at 10m/s × v/10

$$v_1 = \pi \times d_1 \times N_1 / 60 \times 1000 \quad \dots(3)$$

$$v_1 = \pi \times 20 \times 100 / 60 \times 10$$

$$v_1 = 0.105\text{m/s}$$

Assume HI SPEED 878g duck belting 0.023kw/mm/ply

$$\text{Load rating at V m/s} = 0.023 \times 0.105 / 10 \quad \dots(4)$$

$$= 2.41 \times 10^{-4} \text{KN/mm/ply}$$

Belt speed v=0.105m/s so take 10m/s and minimum pulley diameter=20mm

So take

$$d = 90\text{mm}$$

No of plies = 3

$$b = 0.12 / 2.40 \times 10^{-4} \times 3$$

$$b = 166.667\text{mm}$$

Therefore maximum standard belt width for 3 ply

$$b = 100\text{mm}$$

STEP 5: To find the Pulley Width. By using PSG Data Book steps standard pulley width can be determined.

Including 125mm of belt width

Add 13mm

$$\text{So pulley width} = 100 + 13$$

$$= 113\text{mm}$$

To make standard pulley width

Pulley width = 125mm

STEP 6: Calculating Length 'L' of Belt. By using Equation 5.

We know the all values in the equation 5. So easily finding the Length of Belt

$$L = 2c + \pi/2 (d_1 + d_2) + (d_1 - d_2)^2 / 4C \quad \dots(5)$$

$$L = (2 \times 0.110) + \frac{\pi}{2} 0.02 + 0.02 + \frac{(0.02 - 0.02)^2}{4 \times 0.130}$$

$$= 0.22 + 0.0628 + 0$$

$$L = 0.2828\text{m}$$

B. In this step finding the torque for driving pulley motor.

In equation 6 is the formula for Design power but we know that the power of motor. By using this equation 6 torque of motor will be calculated as follows.

$$\text{Power} = 2 \times \pi \times N \times T / 60 \quad \dots(6)$$

Given Power = 100w

Given Speed (N) = 100rpm

$$\text{Torque} = 100 \times 60 / 2 \times \pi \times 100$$

$$\text{Torque} = 9.550 \text{N-m}$$

VII. Conclusion

A dishwasher is not a luxury but a necessity which can make your life a lot easier. The best dishwasher should have a capacity suitable for your family's needs. It should also be easy to use, energy efficient and reasonably quiet. Moreover, the best dishwashers are the ones that can deliver spotless dishes without needing them to be manually rinsed beforehand. This design of automatic dishwasher can be used to wash eating utensils very cleanly and with the ease. As the motors selected can consume much less power so it will be the electrically better. Manual wash is usually done with cold water but hot water helps to kill harmful germs. And the utensils come out dry which means that there is no need for drying them which reduces human efforts to great extent. This is very much efficient in cleaning the dishes without human intervention. This saves lot of time and man power.

Future work might be possible in the Following ways: to reduce the weight of the machine. To

improve the speed of the cleaning process by using alternative motor. To develop new ways to save water and energy. To use the leftover water from prior rinse cycles to pre-rinse the next one.

VII. REFERENCE

- [1] V. Jayakumar, "Dynamics of Machines", Lakshmi publication, Chennai, 2014
- [2] Harja choudry, "Elements of workshop technology", Volume I and II", Media Publisher, Mumbai, 2001.
- [3] R.S.Khurmi and J.K.Gupta., "Design of Machine Elements" S.Chand and Company Pvt. Ltd.
- [4] Stamminger, Rainer (May–June 2004). "Is a machine more efficient than the hand?"(PDF). Home Energy. Retrieved 2010-06-13.
- [5] <http://www.sciencedirect.com/science/article/pii/S0956713513003745> Referred on 28/03/2016
- [6] James N. Boblenz. "How to lace a flat belt". Farm Collector. Retrieved 2010-04-04.
- [7] R.S.Khurmi and J.K.Gupta, "Theory of Machines" S. Chand and Company Pvt. Ltd.
- [8] Indra Mani, "Design and Development of Tractor Drawn Harvester", Vol 81, Published on 2011.

PHOTOGRAPH

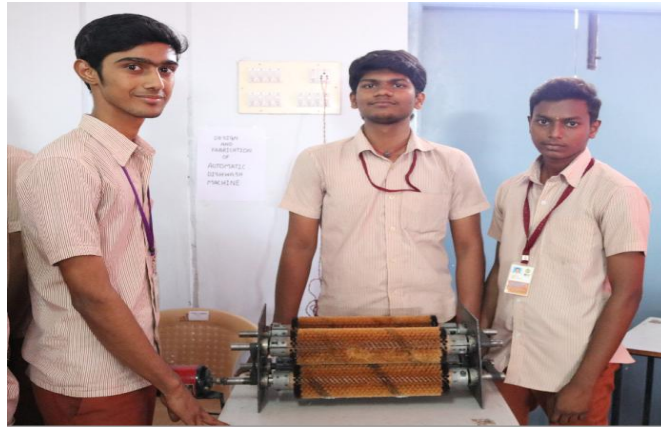

Participated in MECHPRO 2K16 Held at KLNCE



Different Views of Fabricated Model