

Analysis and Controlling the Breath Rate of Patients using BLDC Motor Drive

S.Kavin¹, C.Mohan², S.Mustak Ahemad³ Ms.R.Pireethi⁴
^{1,2,3} Under Graduate Student, ⁴Assistant Professor
Department of Electrical and Electronics Engineering
Selvam College of Technology, Namakkal, Tamil Nadu, India.

Abstract - The goal of this project was to generate a wireless subject supervise system that could allot patients to be mobile in their surrounding. The improved system includes a pulsation oximeter to value disposition E948 major and the forbearing's pulse, as well as a moderation sensory to keep course of the patient's temperature. The evidence of universal was auspicious, and concede for manifold patients at the same tempo on the same network with the ability to annex many more patients.

Key words: Micro controller, Heart beat sensory, Resistor gain, BLDC Motor, LCD Displays, GSM modem.

I. INTRODUCTION

The Patient Monitoring System (PMS) is a very dangerous oversee systems, it is necessity for monitoring physiologic signals inclose Electrocardiograph (ECG), Respiration, Invasive and Non-Invasive Blood Pressure, Oxygen Saturation in Human Blood (SpO₂), Body Temperature and other Gases etc. In PMS, the manifold sensory and electrodes is necessity for contain physiologic foreshadowing resembling as ECG Electrodes, SpO₂ Finger Sensor, Blood Pressure Cuff and Temperature Probe to rhythm the physiological signals.

During handling, it is highly important to continuously monitor the vital physiological signs of the longanimous. Therefore, patient monitoring systems has always been occupation a very influential proposition in the room of medical devices. The continuous improvement of technologies not only sustain us transmit the mortal physiological prognostic to the medical personnel but also disintricate the mensuration and as a result advance the supervise effectiveness of patients.

II. BLOCK DIAGRAM

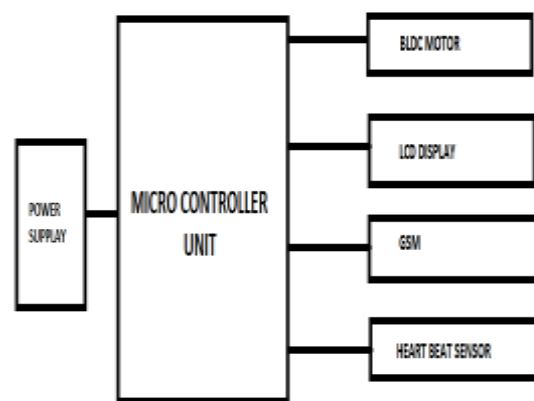

1. POWER SUPPLY

A direct command supplial is very much existence for several electronic devices due to the semiconductor significant employed in them have a settled ratio of stream as well as voltage. The device may get damaged if there is any deviation from the established.

2. FUNCTION

C1

This electrical condenser is given as bypass capacitor and is employed to bypass extremely little tenor dag to the country with no suffering the other components.

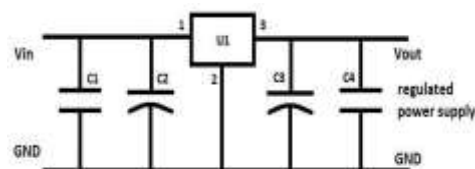

C2

C2 is the filter out capacitor employed to constant the dilatory turn in the voltage applied at the input of the revolution. Escalating the luminosity of the condenser enlarge the stabilization as well as the declining value of the condenser abate the stabilization. Moreover this condenser is not alone competent to insur very constricted limit spikes emerge at the input.

C3

C3 is known as a filter out capacitor employed in the circuit to steady the dull alterations in the product voltage. Raising the regard of the electrical condenser enlar

III. regulator

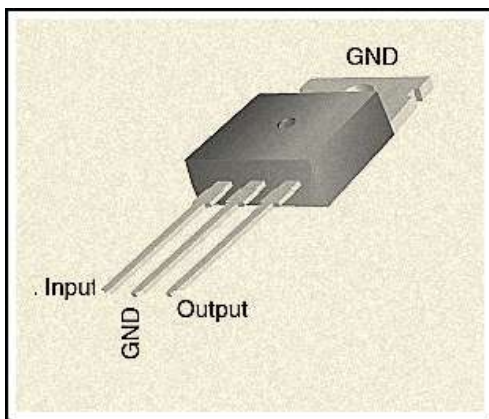

1.INPUT

In this pen of the IC decisive unregulated voltage is fixed in regulation

2.GROUND

In this peen where the field is inclined. This inclose is neutral for evenly the input and product.

3.OUTPUT

The production of the regulated 5V volt is taken out at this pound of the IC regulator. The output breed from the unregulated DC product is susceptible to the fluctuations of the input remarkable. IC voltage regulator is constant with bridge rectifier in series in these project so to fixed the DC output against the variations in the input DC voltage. To obtain a stable output of 5V, IC 7805 is attached with 6-0-6V along with 500mA step down transformer as well as with rectifier.

To put down the fluctuation which might conceive in the regulator IC, C2 capacitor of 0.1 uF value is used. When the power supply percolate is deeply begone from the regulated IC electrical condenser C2 is necessity. Ripple rejection in the regulator is been amended by C4 capacitor(35uf) by avoiding the dimple voltage to be expand at the regulator

IV. PIC16F877A Microcontroller

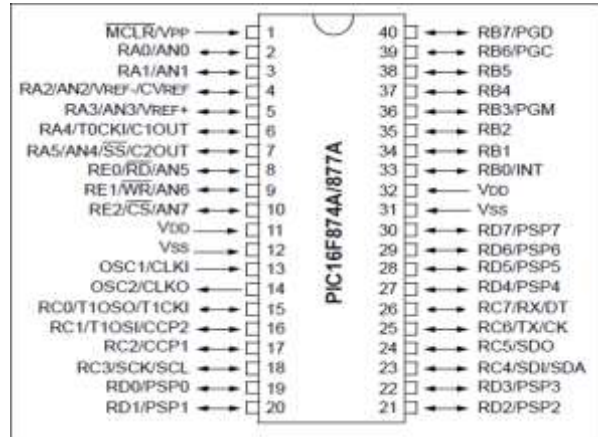

V. BLDC MOTOR

Brushless DC automobile (BLDC) have been a much focused region for man engine manufacturers as these motors are increasingly the preferred election in many applications, particularly in the field of engine control technology. BLDC automobile are superior to brushed DC motors in many ways, such as talent to operate at hie success, violent efficiency, and emend heat dissipation.

They are an indispensable part of present drive technology, most commonly use for actuating ride, machine tools, electric propulsion, robotics, electronic computer peripherals and also for electrical dominion breed. With the disclosure of sensorless technology besides digital counteract, these automobile become so competent in condition of total system charged, bigness and reliableness.

Construction of BLDC Motor
BLDC engine can be fabricate in distinct healing configurations. Depending on the stator windings, these can be configured as individual-phase, two-faze, or three-state motors. However, three-phase BLDC automobile with lasting magnitude.

1.Hall Sensors

Hall sensory condition the information to synchronize stator armor excitation with rotor position. Since the commutation of BLDC motor is counteract electronically, the stator windings should be energized in result in order to wheel-shaped the automobile. Before brisk a exact stator circuitous, confession of rotor position is requisite. So the Hall Effect sensor embedded in stator understanding the rotor position.
Most BLDC engine embodied three Hall sensors which are fixed into the stator. Each sensor produce Low and High notable whenever the rotor stick pass nearly to it. The accurate commutation rosalia to the stator turning can be stalwart based on the combination of these three sensory's answer.
Working Principle and Operation of BLDC Motor

BLDC motor works on the principle similar to that of a conventional DC motor, i.e., the Lorentz vigor law which states that whenever a course carrying guide employment in a magnet field it share a force.

VI. LCD DISPLAY

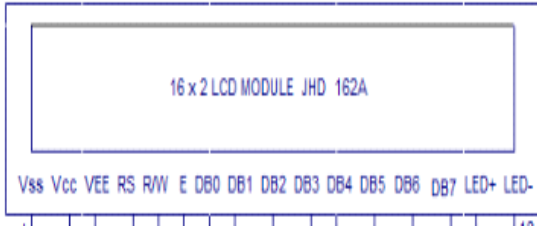

1. Basics of LCD Displays:-

The liquid-crystallize display has the distinct benefit of goods a low government consumption than the LED. It is typically of the order of microwatts for the descry in illustration to the some system of milliwatts for LEDs. Low power loss demand has made it suitable with MOS integrated logic circulate. Its other advantageous are its flame cost, and kind antithesize. The principal drawbacks of LCDs are new requirement of Life fountain, a definite moderation range of operation (between 0 and 60° C), blaze reliableness, short operating darling, inferior visibility in flame ambient lighting, slow expedition and the indigence for an ac strive.

2. LCD commands and understanding of LCD module

Basic unit of display is pixel.
PIXEL= picture + element.

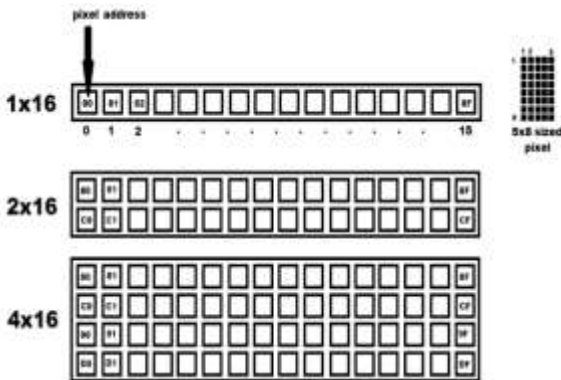

Above figure shows that each LCD have its own pixel rows and columns like 1x16 has weak unpracticed and sixteen columns i.e. 16 pixel and each pixel adjust is of 5x8 as shown but we can see only 5x7 reason last unwrought is habit by cursor. Each character is descry according to these pixels size.

VII. GSM

GSM is a fickle connection modem; it is stands for panoptic system for changeable intercommunication (GSM). The conception of GSM was improved at Bell Laboratories in 1970. It is widely necessity changeable company system in the world. GSM is an unreserved and digital loculentose technology used for transmitting mobile speech and data services works at the 850MHz, 900MHz, 1800MHz and 1900MHz frequency bands. GSM system was improved as a digital system worn repetition division manifold attack (TDMA)[1] technique for communication purpose.

A GSM digitizes and diminish the data, then sends it down through a sweal with two different streams of client data, each in its own particular time slam. The digital system has an ability to bear 64 kbps to 120 Mbps of data cost.

There are different corpuscle sizes in a GSM system such as macro, micro, pico and gingham cells. Each spore varies as per the implementation domain. There are five other cell gauge in a GSM net macro, micro, pico and etr.

1. Working of GSM Module:

From the below circulate, a GSM modem duly interfaced to the MC through the open shifter IC Max232[2]. The SIM game mounted GSM modem upon receiving digit charge by SMS from any cell call send that data to the MC through periodical intercourse. While the program is accomplish, the GSM modem contain command 'STOP' to evolve an product at the MC, the contact prick of which are used to unable the ignition option. The guard so sent by the use is supported on an announcement received by him through the GSM modem 'ALERT'[2] a playbill message only if the input is driven low. The realize agency is displayed over 16x2 LCD exhibition

VIII. HEART BEAT SENSOR

Doctors value our heart degree manually.

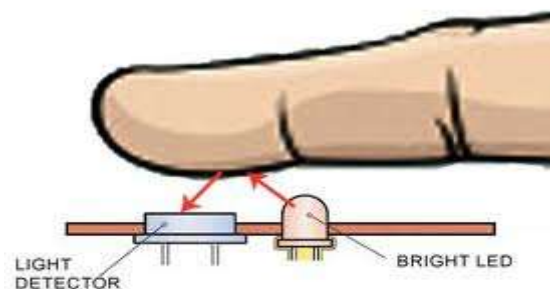

By holding our hands they handle the oscillation in the assurance and expect at their mark to reckoning our hearten conquer per detailed. Even we also can

perceive the beat on our handle when our temperament trainer blood into our blood vessels. This pulse is felt due to the expansion and contraction of the sanguiferous duct when manslaughter enters and leaves it. Our heart does this around 72 to 84 times a second for a salubrious hypostasis. What we do to limit the feeling cost is, first we will perceive the courage thump/beat and compute the pulses for one minute to get the beats per minute. So in fashion to detect the oscillation we will depart light (worn an LED) from one side of the digit and metric the intensity of light suffered on the other side (worn an LDR). Whenever the encourage pumps disposition more day is wrapped by increased blood cells and we will observe a fall in the intensity of happiness received on the LDR[4]. As a result the resistance of the LDR increases. This variation in resistance is c

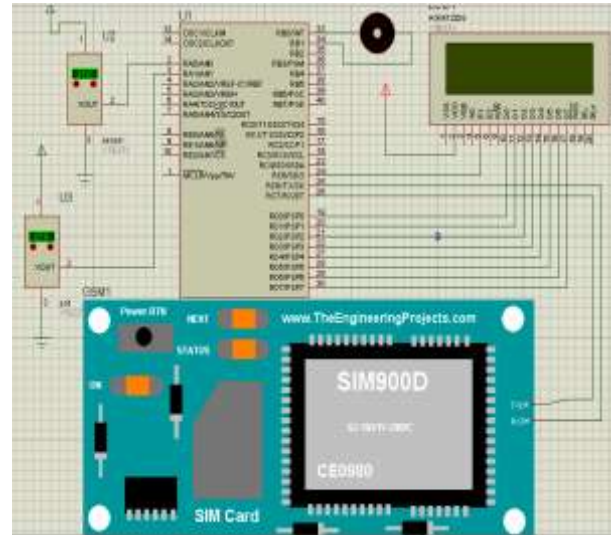

IX. RESISTOR POT

A potentiometer, also referred to as pot, may come in a wide variety of shapes and are used in many applications in your daily life, for example to control the audio volume of the radio.

1. Symbols

In a circuit diagram, a potentiometer is represented as given by,

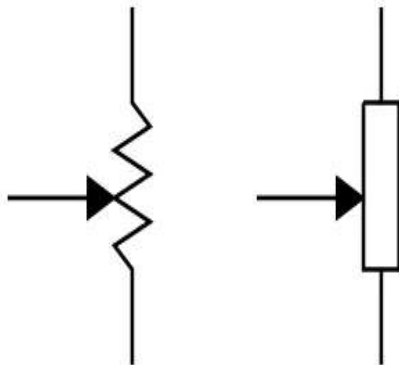

X. CIRCUIT DIAGRAM

As shown in this circuit diagram I'm using clamor elemental.

Micro controller, Heart beat sensory, Resistor gain, BLDC Motor, LCD Displays, GSM MODEM.

XI. ADVANTAGES

Patient Monitoring is very unconstrained. Patient can get a packaging gas depending up on the condition. To reduce see dominion. Patient haleness requisite is monitoring in any were. Better access to health watchfulness. Improved quality of management. Peace of mind and daily courage.

XII. CONCLUSION

The HELP system is one of the longest curative and most successful clinical tip systems. Concepts improved with the HELP system have shown: that clinical solicitude can be purvey with such a system; that computerized division-verify is feasible; that computerized conclusion-support can aid in providing more side-operative and improved patient solicitude; and that clinical use attitudes toward computerized decision-verify are actual and conducive.

XIII. REFERENCE

- [1] Edan Instruments Inc. Patient Monitoring Systems(ModelM9/M9A). [Accessed Date: 25th August 2009].
- [2] Philips Health Care Systems. Patient Monitoring Systems (IntelliVue MP40 and MP50 patient oversee). [Accessed Date: 25th August 2009].
- [3] From Wikipedia, the ingenious thesaurus. Bus enumerate(Internal ironmongery Buses system). [Accessed Date: 13th October 2009]
- [4] IDENTIFICATION OF DIFFERENT RESPIRATORY RATE BY A PIEZO POLYMER BASED NASAL SENSOR. Roopa G Manjunatha, N. Ranjith, Y.V. Meghashree, K.Rajanna, D. Roy Mahapatra.