

# Buckling Analysis of Compression Loaded Composite Cylindrical Shells using Ansys

<sup>1</sup>U.Venkat Raman, <sup>2</sup>Adesh Bhil, <sup>3</sup>V.Suresh

<sup>1</sup>PG Student, Department of Mechanical Engineering, Holy Mary Institute of Technology and Science, Hyderabad, Telangana -501301.

<sup>2</sup>Assistant Professor, Department of Mechanical Engineering, Holy Mary Institute of Technology and Science, Hyderabad, Telangana -501301.

<sup>3</sup>Professor, Department of Mechanical Engineering, Holy Mary Institute of Technology and Science, Hyderabad, Telangana -501301.

**ABSTRACT:-**Composite thin cylindrical shells are most widely used structural forms in Aerospace and Missile applications. In designing efficient and optimized shell structure, they become increasingly sensitive to buckling. It is well known that the experimental display is mainly attributed to geometrical imperfection like damage in the structure, or ovality or local thinning of material etc.

In Missile and Airframe, the composite cylindrical shell structure is generally provided with cutouts for accessing internal components during integration. The cutouts invariably reduce the strength of the composite cylindrical shell and more specifically the buckling load. It has been a design practice to improve strength by addition of Reinforcement around cutout. The

cutout not only introduces stress concentration but also significantly reduce buckling load.

Results from a numerical study of the response of thin-walled compression-loaded quasi-isotropic laminated composite cylindrical shells with unreinforced and reinforced square cutouts are presented. The effects of cutout reinforcement orthotropic and size, on the linear response of the shells are described. The results indicate that a local buckling and deformation occurs in the shell near the cutouts are described when subjected to compression load. Inter laminar and Intralaminar failure occurs on the near the free edge of the cutouts.

In general, reinforcement around a cutout in a compression-loaded shell is shown to retard or eliminate the local buckling response, Interlaminar, intralaminar and failure near the cutout and increase the

buckling load and decrease the deformation of the shell. To eliminate the Interlaminar and Intralaminar failure by change in material properties of Graphite/Epoxy tape unidirectional property

**KEYWORDS** – Cylindrical shell, CATIA, ANSYS, Deformation, Interlaminar stress

## **I. INTRODUCTION**

The composite is a combination of two or more materials combine on a microscopic scale to give superior properties than original materials include strength, fatigue life, stiffness, temperature dependent behavior, corrosion resistance, thermal insulation, wear resistance, thermal conductivity, attractiveness, acoustical insulation and weight. The composites also possess high specific strength, high specific strain, low thermal coefficient of expansion, high thermal conductivity, low weight, wear and corrosion resistance, etc. Composites find its application in Aerospace, Defense, Automobiles, Machine tool, Marine, Construction industry, Chemical industry and biomedical equipment.

In general structural discontinuities in the form of cut out are inevitable in the design and construction of many structures particularly in the Aerospace industry. Cut outs in circular cylindrical shell, which constitute the primary

load carrying members of a great many Aerospace vehicles, especially in connection with their effect on the bucking of cylinders .in the applications of thick shell structures it is often necessary to design a cylindrical shell with a square hole in it side .a hole can accrue as an access port in a missile skin or aircraft fuselage, a ship hatch, or for numerous other reasons.

Thin-walled shell structures are a fundamental component found in Aircraft, Spacecraft, and Launch vehicles. In many applications, these structural components contain cut outs or openings that serve as doors, windows, or access ports, or are used to reduce weight. Often, some type of reinforcement is used around a cut out to eliminate local deformations and stress concentrations that can cause local buckling or premature material failures. In addition, it is important to understand performance enhancements that can be obtained by using lightweight fibre-reinforced composite materials.

If the cylindrical shell is uniformly compressed in the axial direction, buckling symmetrical with respect to the axis of the cylinder. The critical value of the compressive force  $N_{cr}$  per unit length of the edge of the shell can be obtained by using the energy method. As long as the shell remains

cylindrical, the total strain energy is the energy of axial compression. When buckling begins, we must consider in addition to axial compression, the strain of the middle surface in the circumferential direction and also bending of the shell. Thus strain energy of the shell is increased, at the critical value of the load, this increase in the energy must be equal to the work done by the compressive load as the cylinder shortens owing to buckling.

We assume for radial displacements during buckling the expression,

$$W = A \sin (\pi x) / l$$

Where  $l$  is the length of the cylinder

Critical stress ( $\sigma_{cr}$ ) is found by using the expression,

$$\sigma_{cr} = Eh / (r \sqrt{3 (1-\nu^2)})$$

### A. Problem

The finite element modeling and 3-dimensional analysis is done to study the effects Inter laminar, Inter laminar Buckling factor and Deformation in buckling analysis of shell with and without reinforcement of Graphite/Epoxy composite laminate subjected to compressive load.

The seven shells considered in this study were analyzed with the Structural analysis of linear shell. The 2-D diagrams of finite element model of a composite shell are

shown in below fig1, fig2, fig3, fig4. A typical finite element model of a shell with centrally located square cut outs dimensions of a 1mm by 1mm. The shells have a length  $L$  of 16mm a radius  $R$  of 8mm. The shells were modelled as geometrically perfect, 8-ply-thick  $[\pm 45/0/90]_s$  quasi-isotropic graphite-epoxy laminates, in which each lamina ply had a thickness of 0.005mm. The cut out reinforcement consists of additional square-shaped lamina plies added to the shell-wall laminate at the shell-wall mid-surface that are aligned concentrically with respect to the square-shaped cutout in the shell. The square shaped reinforcement sizes included a 2.4mm by 2.4mm.

### 2D-Drawings

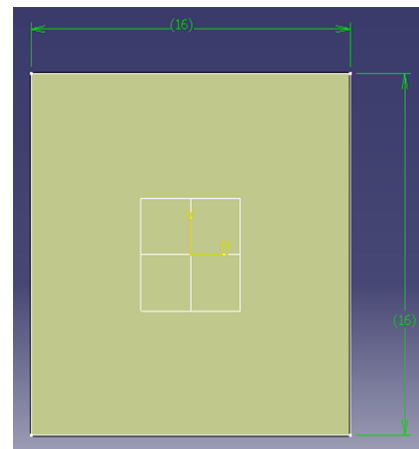

Fig1. Front view of composite shell

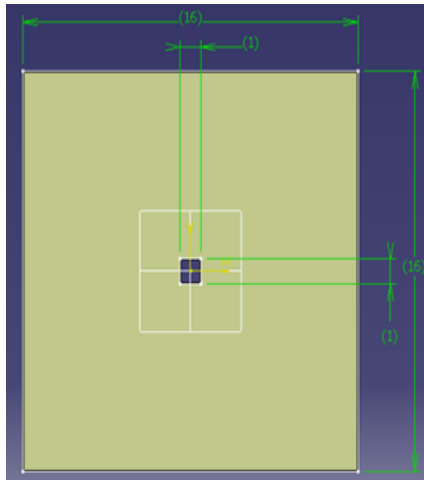

Fig2. Composite shell with hole

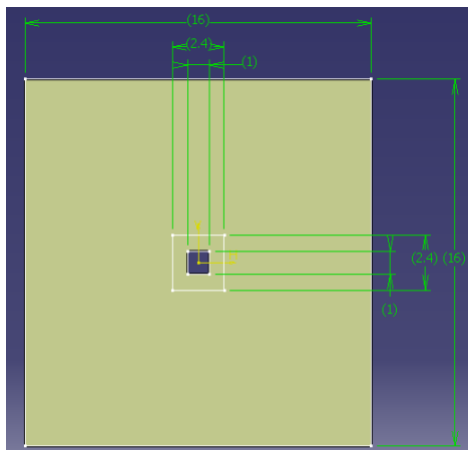

Fig3. Composite shell with reinforced hole

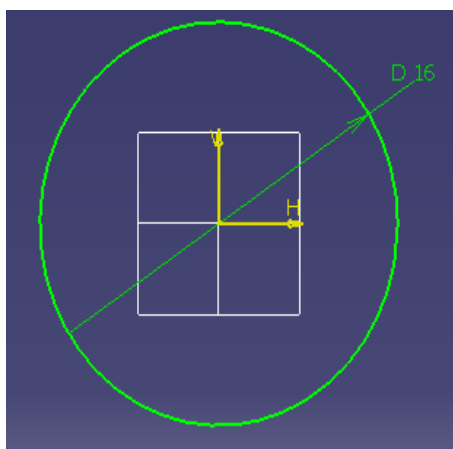

Fig4. Top view of composite shell

Many studies have been conducted

which show that a cut out in an isotropic shell structure can have a significant effect on the response of the shell. In particular, results indicate that a cut out in a shell structure causes a local response to occur near the cut out when the shell is subjected to load. This local response can consist of large out-of-plane deformations and large-magnitude, rapidly varying stresses near the cut out. If the applied load is a compressive load, the cut out can cause a local buckling response to occur in the shell at applied load levels lower than the general instability load of the corresponding shell without a cut out. For some cases, this local buckling response results in a stable post buckling response localized near the cut out and additional load can be applied to the shell occurs.

#### **DIMENSIONS OF MODEL**

Length of the shell= 16mm

Radius of the shell= 8mm

Thickness of shell= 0.04mm

Thickness of ply= 0.005mm

No of plies= 8

Dimension of cut outs = 1mm\*1mm

## PROPERTIES OF MATERIAL

Longitudinal modulus( $E_l$ ) = 18.5e6 MPa

Transverse modulus( $E_t$ ) = 1.64e6 MPa

In-plane shear modulus( $G_{xy}$ ) = 0.87e6MPa

In-plane shear modulus( $G_{yz}$ ) = 0.51e6MPa

Major Poisson's ratio( $\nu$ ) = 0.30.

## Boundary Conditions

The one end of the shell considered all Degrees of freedom (Bottom) and other end of the shell is applied compressive load of 2000N (top).

## II LITERATURE SURVEY

Cervantes, J.A. and Palazotto, A. Nar represented by thin cylindrical shells are most sensitive to buckling. As the compressive load is applied on the shells, it leads to failure at certain load, which is critical load. As the cylindrical shells have wide range of applications in varied fields, its structural design for safety is very much essential. Tremendous work has been carried out earlier in the field of buckling of thin cylindrical shells with cutouts.

Hashin Z presented a paper on progressive failure methodology to simulate the initiation and material degradation of a laminated panel due to intralaminar and interlaminar failures. Initiation of intralaminar

failure can be by a matrix-cracking mode, a fibre-matrix shear mode, and a fibre failure mode.

Almroth, B.O. studies have been conducted on the response of compression-loaded curved shells with reinforced cut outs, and the few results that do exist are limited to isotropic shells.

The traditional method for the preliminary design of a reinforced cut out in a thin-walled shell structure is based on a linear analysis of a flat plate with a square cut out.

## III FINITE ELEMENT METHOD

The basic concept in FEA is that the body or structure may be divided into smaller elements of finite dimensions called "Finite Elements". The original body or structure is then considered as an assemblage of these elements connected at a finite number of joints called "Nodes" or "Nodal points". Simple functions are chosen to approximate the displacements over each finite element. Such assumed functions are called "shape functions". This will represent the displacement within the element in terms of the displacement at the nodes of the element.

The Finite Element Method is a mathematical tool for solving ordinary and

partial differential equations. Because it is a numerical tool, it has the ability to solve the complex problems that can be represented in differential equations form. The applications of FEM are limitless as regards the solution of practical design problems. In the recent years, FEA has been universally used to solve structural engineering problems. The departments, which are heavily relied on this technology, are the automotive and aerospace industry. Due to the need to meet the extreme demands for faster, stronger, efficient and lightweight automobiles and aircraft,

Manufacturers have to rely on this technique to stay competitive.

### Shell 99 Element Description

SHELL99 may be used for layered applications of a structural shell model. While SHELL99 does not have some of the nonlinear capabilities of SHELL91, it usually has a smaller element formulation time. SHELL99 allows up to 250 layers. If more than 250 layers are required, a user-input constitutive matrix is available.

The element has six degrees of freedom at each node: translations in the nodal x, y, and z directions and rotations about the nodal x, y, and z-axes.

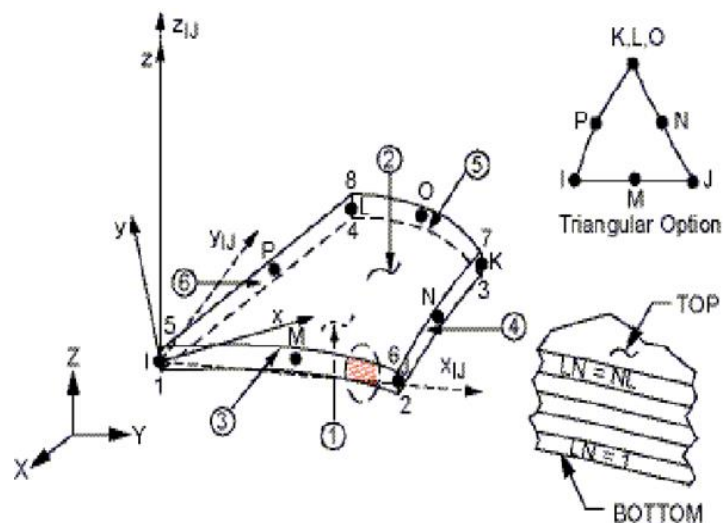

**Figure 5. SHELL99 element Geometry**

$x_{IJ}$  = Element x-axis if ESYS is not supplied.

$x$  = Element x-axis if ESYS is supplied.

LN = Layer Number

NL = Total Number of Layers

SHELL99 input data

The geometry, node locations, and the coordinate system for this element are shown in Figure 5: "SHELL99 Geometry". The element is defined by eight nodes, average or corner layer thicknesses, layer material direction angles, and orthotropic material properties.

The following graph shows element formation and stress recovery time as a function of the number of layers. While SHELL91 uses less time for elements of under three layers, SHELL99 uses less time for elements with three or more layers.

## RESULTS AND DISCUSSIONS

The results are studied to understand the influence of cut outs on buckling strength of shell of same material and also the extent of improvement by providing reinforcement around cut outs. Numerically predicted results for selected compression-loaded quasi-isotropic laminated cylindrical shells with unreinforced and reinforced cut outs are presented in this section. The results were obtained from finite-element models of geometrically perfect shells subjected to a uniform axial end-shortening.

The results are studied to understand the influence of cut outs on buckling strength of shell of same material and also the extent of improvement by providing reinforcement around cut outs. Numerically predicted results for selected compression-loaded quasi-isotropic laminated cylindrical shells with unreinforced and reinforced cut outs are presented in this section. The results were obtained from finite-element models of geometrically perfect shells subjected to a uniform axial end-shortening.

### Without Reinforcement

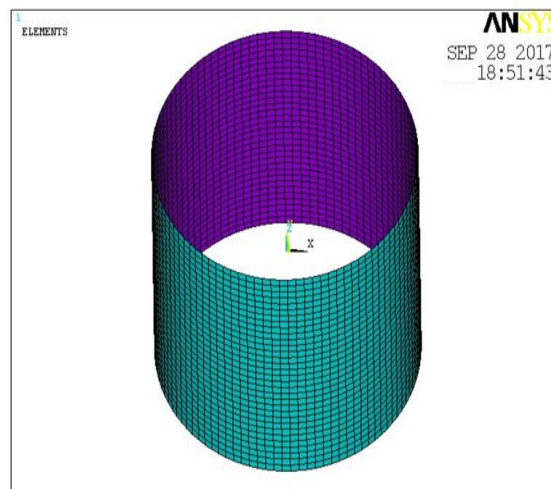

**Fig6. Composite shell without hole**

Fig6. shows the mesh generation of the model of without cut out, the total no of elements and nodes are 3200, 9800 respectively.

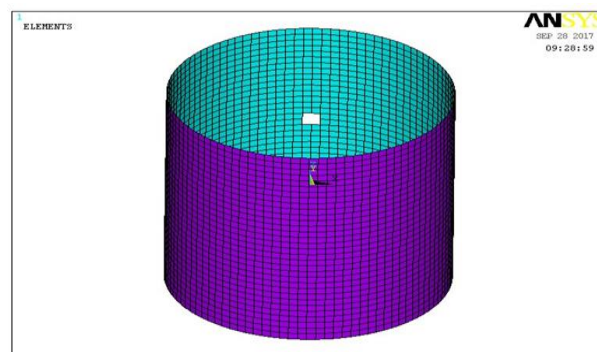

**Fig7. Composite shell with one hole**

Fig7. shows the mesh generation of the model of with one hole, the total no of elements and nodes are 3196, 9795 respectively.

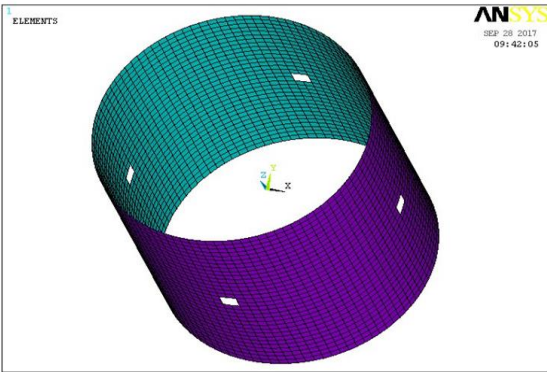

**Fig8. Composite with four holes**

Fig8. shows the mesh generation of the model of with two hole, the total no of elements and nodes are 3192, 9790 respectively.

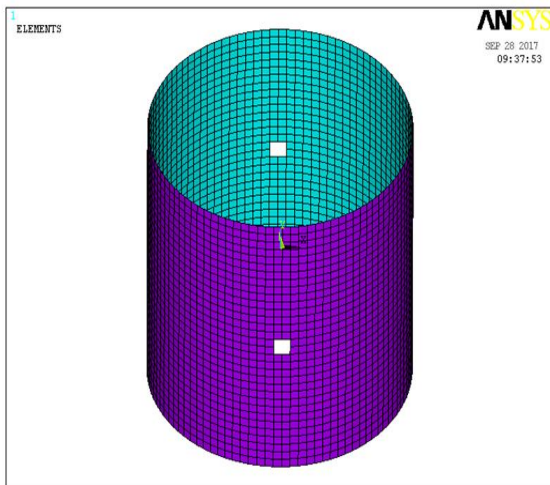

**Fig9. Composite shell with two holes**

Fig9. Shows the mesh generation of the model of with two hole, the total no of elements and nodes are 3184, 9780 respectively.

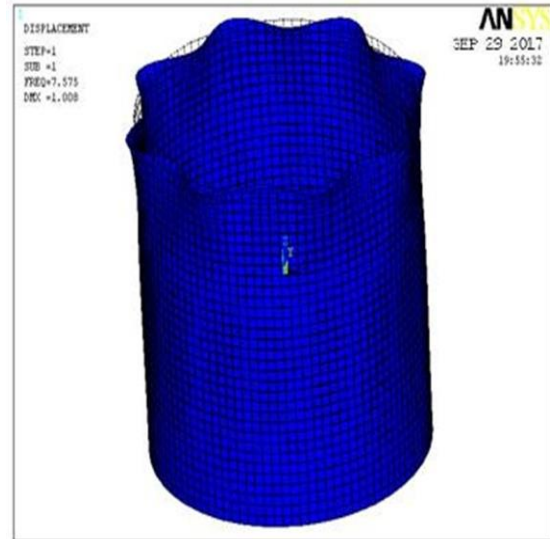

**Fig10. Deformation without hole**

Fig10. shows the max buckling factor and deformation of without hole is 7.575, 1.008 respectively.

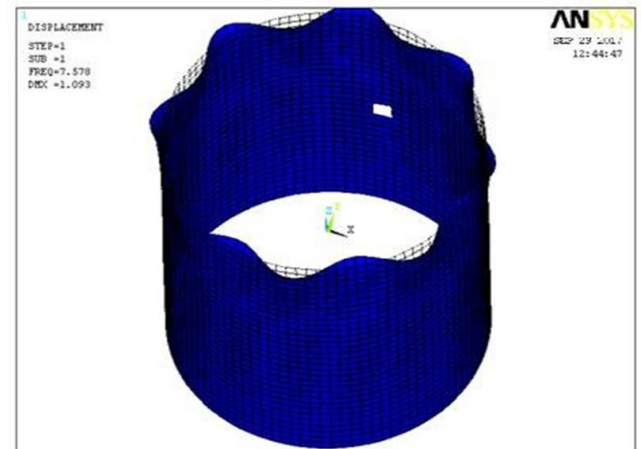

**Fig11. Deformation with one hole**

Fig11.shows the max buckling factor and deformation of with one hole is 7.570, 1.093 respectively.



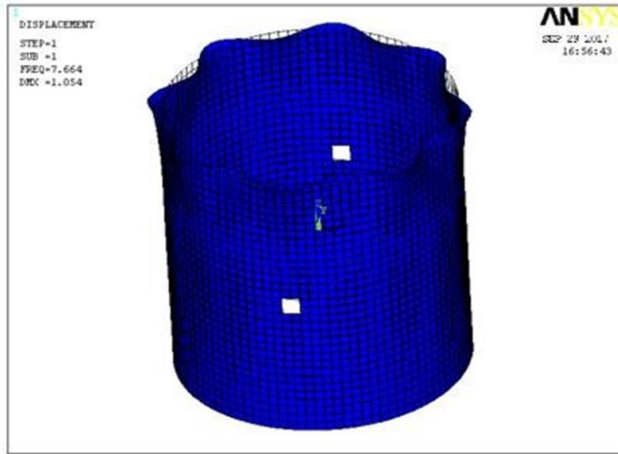

**Fig12. Deformation with two holes**

Fig12. Shows the max buckling factor and deformation of without hole is 7.664,1.054 respectively.

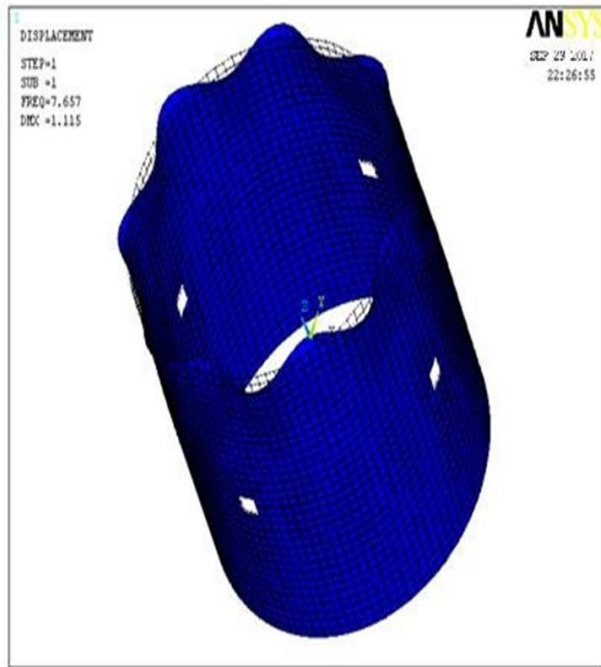

**Fig13. Deformation with four holes**

Fig13. Show the maximum buckling factor and deformation of with four holes is 7.657 , 1.115 respectively.

**Change in ratio of  $E_t/E_l$  tables**

$E_t/E_l$	Without hole	With 1holes	With 2holes	With 4holes
0.02	7.181	7.186	7.287	7.212
0.04	7.298	7.302	7.398	7.325
0.06	7.413	7.416	7.508	7.437
0.08	7.575	7.578	7.664	7.595
0.10	7.639	7.641	7.725	7.657

$G_{xy}/E_l$	without cutouts	with 1hole	with 2hole	with 4hole
0.02	1.003	1.051	1.049	1.086
0.04	1.008	1.093	1.054	1.122
0.06	1.002	1.084	1.057	1.121
0.08	1.002	1.075	1.061	1.109
0.1	1.004	1.065	1.068	1.105

Above table Variation of deformation with change in ratio of  $G_{xy}/E_l$  shows the variation of deformation against the  $G_{xy}/E_l$ . From the figure it is observed that the deformation increases for with one hole, with two holes and then decreases slightly with four holes. In case of without hole there is slight increase and then decrease in deformation with the increase in the

ratio of  $G_{yz}/E_t$ . Maximum deformation is observed with four holes and minimum without hole.

$G_{yz}/E_t$	without cutouts	with 1hole	with 2hole	with 4hole
0.02	5.575	7.578	7.664	7.595
0.04	7.604	7.607	7.694	7.624
0.06	7.639	7.642	7.731	7.660
0.08	7.665	7.669	7.758	7.687
0.10	7.686	7.689	7.779	7.708

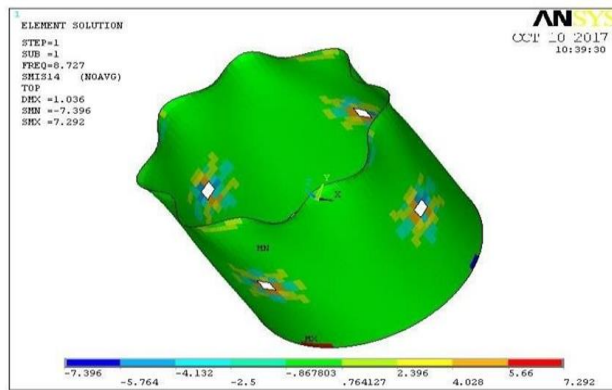

**Fig14. Interlaminar shear stress with four holes.**

Fig14. Shows that maximum interlaminar shear stress is observed away from the hole in case of reinforcement, where as it is observed at free edge of cut out in case of without reinforcement. The max, min stress is 7.292, - 3.396 respectively.

#### IV. CONCLUSION

Results from a numerical study of the response of thin-wall compression- loaded quasi-isotropic laminated composite cylindrical shells with reinforced and unreinforced square cut outs have been presented. The results identify some of the effects of cut out-reinforcement isotropic, size, and thickness on the linear response of the shells. A high-fidelity linear analysis procedure has been used to predict the linear response of the shells. In general, the addition of reinforcement around a cut out in a compression-loaded shell can have a significant effect on the shell response. Results have been presented that indicate that the reinforcement can affect the local deformations and stresses near the cut out and retard or suppress the onset of local buckling in the shell near the cut out.

1. Interlaminar failures are observed at bottom of shell without cut out.
2. Interlaminar failures are observed at free edge of cut out in case of without reinforcement.
3. Interlaminar failures are observed at away from cut out of shell with reinforcement.
4. Interlaminar failures are reduced by increasing the  $G_{xy}/E_t$  as compared with increasing the  $G_{yz}/E_t$  and  $E_t/E_t$ .

5. Deformations are greatly reduced by adding reinforcement.
6. Critical loading also increased considerably by adding reinforcement.
7. It is observed that intra laminar failures like fibre cracking and matrix cracking with cut out are reduced considerably as compared to without reinforcement.

### **References**

1. Lur'e, A. I., "Statics of Thin-walled Elastic Shells," State Publishing House of Technical and Theoretical Literature, Moscow, 1947; translation, AEC-tr-3798, Atomic Energy Commission, 1959.
2. Lekkerkerker, J. G., "On the Stress Distribution in Cylindrical Shells Weakened by a Circular Hole," Ph.D. Dissertation, Technological University, Delft, The Netherlands, 1965.
3. Brogan, F. A. and Almroth, B. O., "Buckling of Cylinders with Cutouts," AIAA Journal, Vol. 8, No. 2, February 1970, pp. 236-240.
4. Tennyson, R. C., "The Effects of Unreinforced Circular Cutouts on the Buckling of Circular Cylindrical Shells," Journal of Engineering for Industry, Transactions of the American Society of Mechanical Engineers, Vol. 90, November 1968, pp. 541-546.

5. Starnes, J. H., "The Effect of a Circular Hole on the Buckling of Cylindrical Shells," Ph. D. Dissertation, California Institute of Technology, Pasadena, CA, 1970.
6. Cervantes, J. A. and Palazotto, A. N., "Cutout Reinforcement of Stiffened Cylindrical Shells," Journal of Aircraft, Vol. 16, March 1979, pp. 203-208.
7. MadhujitMukhopadhyay "Mechanics of composite Materials and Structures"
8. Hilburger, M. W., Britt, V. O., and Nemeth, M. P., "Buckling Behavior of Compression-Loaded Quasi-Isotropic Curved Panels with a Circular Cutout," International Journal of Solids and Structures, Vol. 38, 2001, pp. 1495-1522.
9. Hashin Z. Failure criteria for unidirectional fibre composites. J ApplMech 1980; 47: 329-34
10. Almroth, B. O. and Holmes, A. M. C., "Buckling of Shells with Cutouts, Experiment and Analysis," International Journal of Solids and Structures, Vol. 8, 1972, pp. 1057- 1071.
11. Starnes, J. H., Jr., "Effect of a Slot on the Buckling Load of a Cylindrical Shell with a Circular Cutout, " AIAA Journal, Vol. 10, No. 2, February 1972, pp. 227-229.