

Implementation of Safety System for Under Mines Using Wireless IEEE 802.15.4 Personal Area Network Technology

Dr.K.Amit Bindaj, N.Nagaraju, Mr. Gandham Srinivasa Rao, . Baloji Naik

Professor, Department of ECE, Assoc Professor, Department of ECE, Assoc Professor & HOD , Department of ECE, Assoc Professor, Department of ECE,
Swarna Bharathi Institute of Science &Technology, Sai Tirumala NVR Engineering college, Bharathi Institute of Science &Technology, Khammam, Telangana.

Abstract:

In the Era of embedded technology, the Zigbee protocols are used in more and more applications. Because of the rapid development of sensors, microcontrollers, and network technology, a reliable technological condition has been provided for our automatic real-time monitoring of coal mine. The application designs a monitoring system for coal mine safety based on Zigbee wireless sensor network. The underground system collects temperature, humidity and methane values of coal mine through sensor nodes in the mine; it also collects the number of personnel inside the mine with the help of an IR sensor, and then transmits the data to information processing terminal based on ARM. The terminal sends the data to the ground section through Zigbee, and in the ground section, the processing terminal monitors the data and sends the data to the PC to save them and for remote users to inquire .An SMS is also send to the corresponding member through GSM modem which is connected to the controller. If any data is received, the received data is compared with the predefined threshold values, if the received values are more than the threshold values then buzzer will be on. So that warning to the personnel will occur.

Keywords--- Embedded Board, Zigbee Wireless Sensor Network, and LAN.

I.INTRODUCTION

The existing monitoring systems underground of coal mine mostly use cable network and very often of them use wireless sensor networks but can't provide the details of the number of personnel in the mines [1]. When an accident happened, especially explosion, the sensors and cables usually were damaged fatally, and couldn't provide information for rescue search and detection events [2].In this application, Wireless sensor network[3] can solve the key issues of communication bandwidth, mobile data transmission, staff orientation, working surface real-time monitoring, synchronization monitoring and so on.

Now a day's every system is automated in order to face new challenges. In the present days

Automated systems have less manual operations, flexibility, reliability and accurate. Due to this demand every field prefers automated control systems. Especially in the field of electronics automated systems are giving good performance. And this is realized by making use of Zigbee technology for communication [4]. Zigbee is new wireless technology guided by IEEE 802.15.4 Personal Area Network standard. It is primarily designed for the wide ranging controlling applications and to replace the existing non-standard technologies. It currently operates in 868MHz band at a data rate of 20Kbps in Europe, 914MHz band at 40kbps in USA, and the 2.4GHz ISM bands Worldwide at a maximum data-rate of 250kbps.Table I. shows a comparison of different transmission media.

TABLE I. Comparison of Different Transmission Media

Characteristics	Infrared	RF Module	Blue Tooth	Zigbee
Power Consumption	Low	Medium	Medium	Low
Controlled Units	1	1	7	254
Distance	15m	50m	100m	100m
Transfer Rate	38Kbps	4800bps	1Mbps	250Kbps
Expansion	Low	Low	Medium	High

This article designs a monitoring system based on Zigbee technology to build wireless sensor network. The sensor nodes in the underground section will send the collected data to an embedded network controller based on ARM kernel. And then the controller receives the data and sends them to the ground PC by the use of Zigbee protocol. With the concept of M2M (machine to machine, machine to mobile, mobile to machine), the ground PC transmits the monitoring results to the mobile phones through GPRS, and the abnormal situations can be dealt with in time. In addition, the mobile inquiring service can also be supported.

II. DESIGN AND PROPOSAL FOR SYSTEM

In this project there are two sections. The first section is underground section and another section is ground section. The overall block diagram of the system is as shown in Fig.1. The designed systems are placed in different parts of the mine and connected by means of Zigbee. In underground section the sensors will sense the environment conditions such as temperature, humidity, gas etc., and this information is send to ADC of the micro controller, the number of members inside the coalmine is also obtained by means of IR sensor. Microcontroller displays this information in the Liquid Crystal Display and sends through Zigbee transmitter. In ground section Zigbee receiver take that information and send to the controller and controller sends the information to GSM modem and as well as displaying on the LCD. Here GSM modem sends the message to mobile when sensors exits there threshold level.

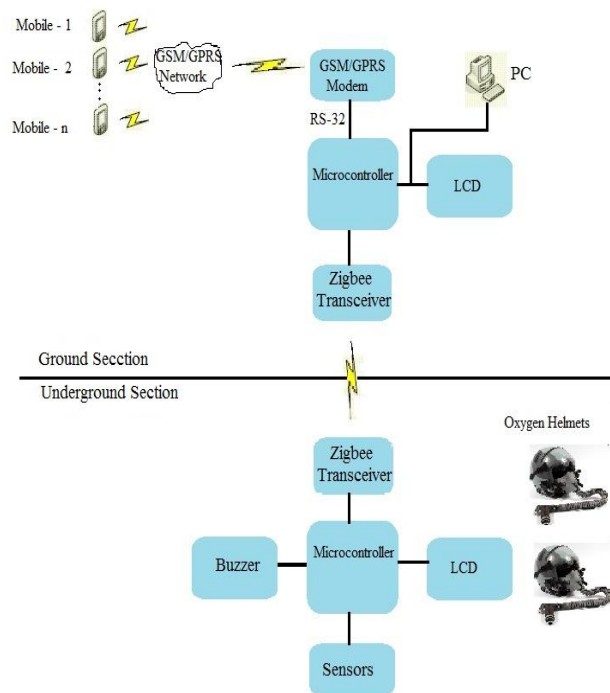

Figure 1. Block Diagram of Designed System

Under Ground Section

In the underground section, the parameters temperature, humidity and gas are measured by means of respective sensors and the output voltage measured by them is directly connected to the ADC of the ARM, as the output voltage never exceeds 5V, there is no need of connecting a signal conditioning circuit. The number of people inside the coalmine is monitored by the help of IR sensor. During a hazard this information will be useful to know whether there are any people remained inside the coalmine. Information regarding the safety measures like wearing oxygen helmets etc., will be already given to

the workers so that they can save their life. If any of the received parameters are beyond the ultra limit, then a Buzzer will be ON, giving warning to the people. The parameters are displayed on the LCD screen and as well as transmitted to the Ground Section through the Zigbee Transceiver.

Ground Section

In the Ground Section, the Zigbee Transceiver receives the information and sends to the ARM controller. The LCD connected to the controller displays the information in the Ground Section. The controller is connected to the GSM modem through RS232. A number of mobile phones to which the data has to be sent is connected to the modem through GSM network. In addition the controller is connected to PC; the measured values are continuously displayed and stored in PC for future use.

III. SYSTEM HARDWARE DESIGN

The detailed description of each of the block in the block diagram of the designed system is as follows.

A. Hardware Structure of Processing Terminal

The main module of the ground and underground sections is the LPC 2148 microcontroller based on the ARM7TDMI-S structure from Philips, which integrates SRAM controller, flash controller, two serial interface controllers, PWM controller, two 12C controllers, SPI and SSP interfaces real-time clock, two 10bit ADC's and a single 10 bit DAC, built in Embedded Trace debug interface and other external control modules, and also provides Thumb16-bit compressed instruction set [5].

The processing terminal makes protocol conversion according to application. At least a RS232 is provided to connect with Zigbee node and two are designed at each section in our project .One for the Zigbee node in both sections and another one for GSM connection in Ground Section [6]. The hardware structure of processing terminal is shown in Fig 2.

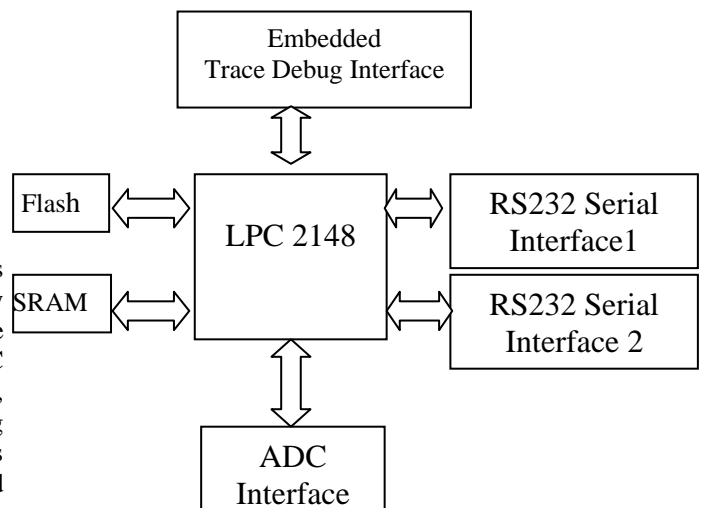

Figure 2. The Hardware Structure of Processing Terminal.

B. Hardware Structure of Sensor Node

The hardware structure of sensor node is as shown in Fig3. The sensors are directly connected to LPC2148 and no signal conditioning is required because the voltage never exceeds 5V.ADC0 has 6 channels of which 3 channels are used to monitor the temperature, humidity and gas values. Two IR sensors are used in our project, one at the entrance and one at the exit section. The IR sensors are connected to the interrupt pins of the microcontroller.

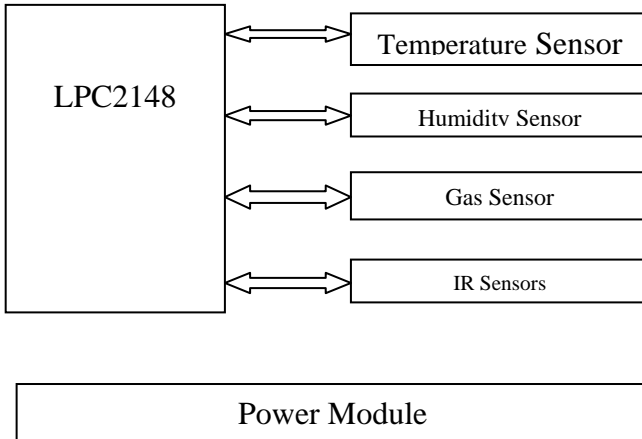

Figure 3. Hardware Structure of Sensor node.

C. Liquid Crystal Display

LCD is connected to Port1 (P1.16 to P1.21) of the microcontroller. It is used to display messages (Either error or accepted). Variable resistor connected to Pin3 of LCD, is used to control the brightness of LCD.LCD is a low cost, low power device capable of displaying text and images. LCD's are extremely common in embedded systems, since such systems often do not have video monitors like those that come standard with desktop systems LCD can be found in numerous devices like watches, fax and copiers and calculators. A variable or fixed resistor must be used on any LCD module as it appears in the above schematic. To send any command to the LCD, make pin RS=0. For data, make RS=1. Then sends a high – to-low pulse to the E pin to enable the internal latch of the LCD. Fig4. Shows how LCD is interfaced to Microcontroller

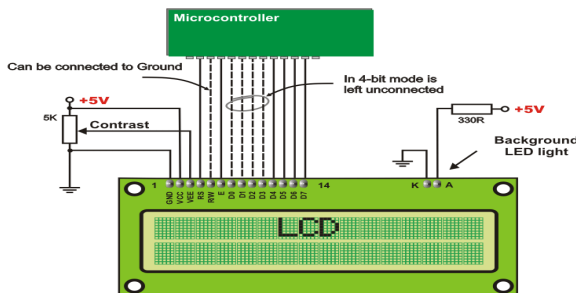

Figure 4. Interfacing LCD to Microcontroller

D. GSM Modem:

In the Ground Section, the UART0 of the microcontroller is connected to the GSM Modem. The Block Schematic of the GSM Modem is shown in Fig.5. A **GSM modem** is a specialized type of modem which accepts a SIM card, and operates over a subscription to a mobile operator, just like a mobile phone. From the mobile operator perspective, a GSM modem looks just like a mobile phone.

When a GSM modem is connected to a computer, this allows the computer to use the GSM modem to communicate over the mobile network. While these GSM modems are most frequently used to provide mobile internet connectivity, many of them can also be used for sending and receiving SMS and MMS messages. A GSM modem can be a dedicated modem device with a serial, USB or Bluetooth connection, or it can be a mobile phone that provides GSM modem capabilities.

GSM modems can be a quick and efficient way to get started with SMS, because a special subscription to an SMS service provider is not required. In most parts of the world, GSM modems are a cost effective solution for receiving SMS messages, because the sender is paying for the message delivery.

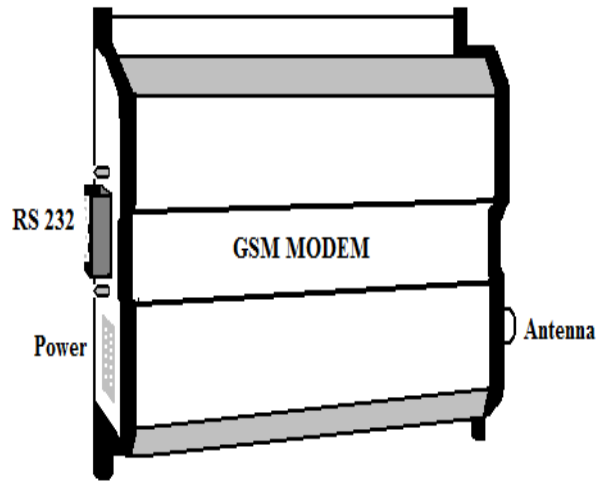

Figure 5. GSM Modem

E. Zigbee

Zigbee is a specification for a suite of high level communication protocols using small, low-power digital radios based on the IEEE 802.15.42003 standard for Low Rate Personal Area Networks (LR-WPANs), such as wireless light switches with lamps, electrical meters with in-home-displays, consumer electronics equipment via short-range radio needing low rates of data transfer. The technology defined by the Zigbee specification intended to be simpler and less expensive than other WPANs such as Bluetooth. Zigbee is targeted at radio-frequency (RF) applications that require a low data rate, long battery life, and secure networking.

The IEEE 802.15.4 standard is a simple packet data protocol for lightweight wireless networks and specifies the Physical (PHY) and Medium Access Control (MAC) layers for Multiple Radio Frequency (RF) bands, including 868 MHz, 915 MHz, and 2.4 GHz. The IEEE 802.15.4 standard is designed to provide reliable data transmission of modest amounts of data up to 100 meters or more while consuming very little power. IEEE 802.15.4 is typically less than 32 kb in size, featuring a 64-bit address space, source and destination addressing, error detection, and advanced power management.

Zigbee modules feature a UART interface, which allows any microcontroller or microprocessor to immediately use the services of the Zigbee protocol.

All a Zigbee hardware designer has to do in this age is ensure that the host's serial port logic levels are compatible with the Zigbee's 2.8- to 3.4-V logic levels. The logic level conversion can be performed using either a standard RS-232 IC or logic level translators such as the 74LVTH125 when the host is directly connected to the Zigbee UART. The below Fig.6 gives the pin diagram of transceiver.

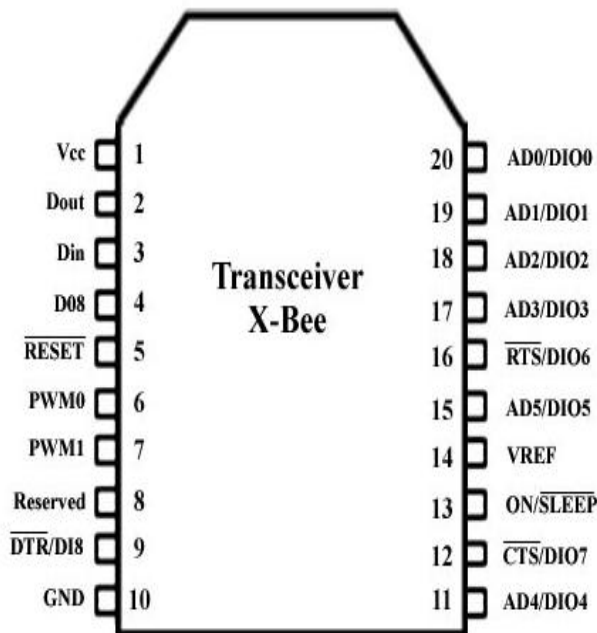

Figure 6.Pin Diagram of Zigbee Transceiver.

IV.SYSTEM SOFTWARE DESIGN

The design of software section consists of designing of the Ground Section and Under Ground Section. The flow charts for the Ground and Under Ground sections are shown in Fig.7 and Fig .8 respectively.

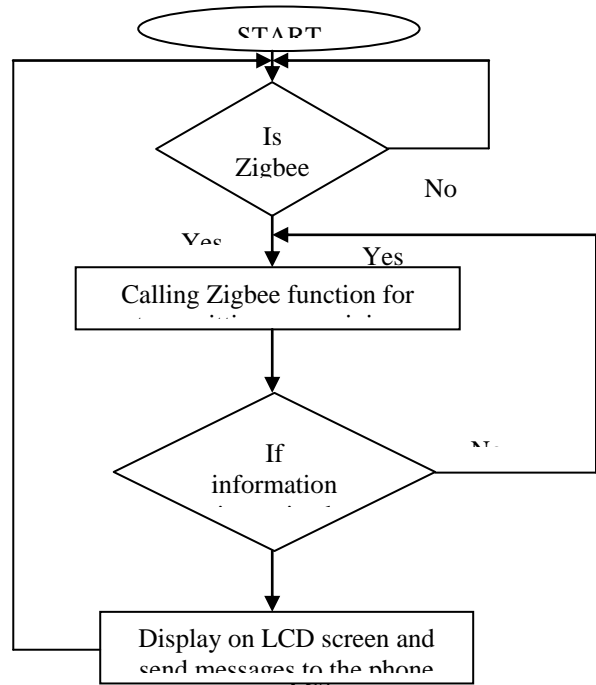

Figure 7.Flow Chart for the Ground Section

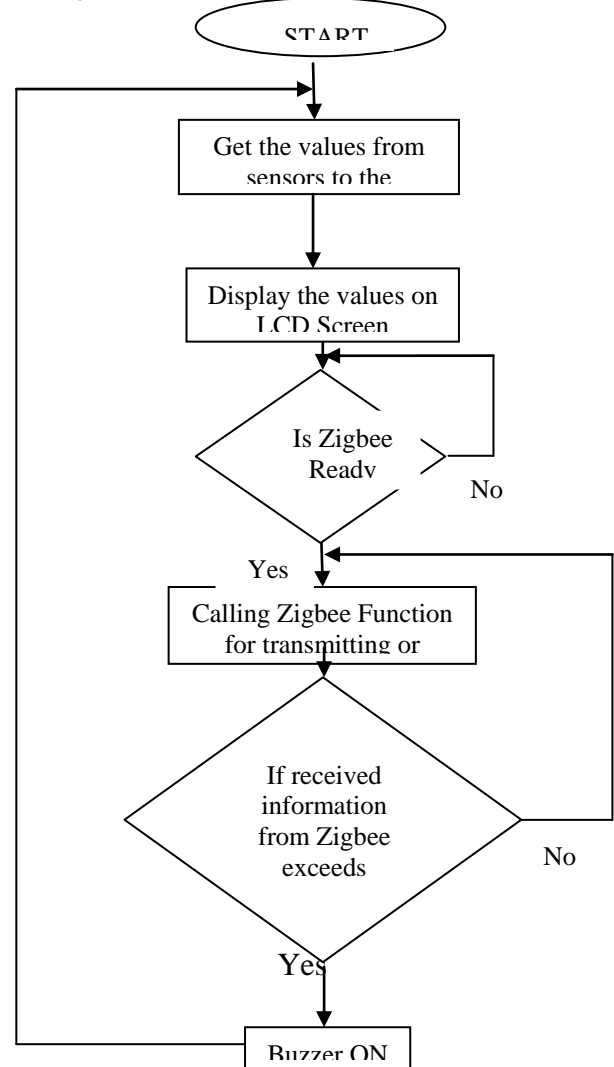

Figure 8.Flow chart for the Under Ground Section.

V.RESULTS

By implementing this paper, the temperature, humidity and gas values of the coalmine are continuously monitored at the underground and ground sections and stored in the PC. The numbers of personnel working inside the coalmine are also monitored. In case if any of the data is ultra-limit, it warns the personnel inside to come out by means of a Buzzer. The personnel, who remained inside the mine and can't come off the mines, will use the oxygen helmets. The related personnel of safety will take action to bring them out safely.

VI.CONCLUSION

In this application, as we are storing the values of the parameters in the PC, the stored values can be used to detect the hazards before they happen. As we are giving the information to the personnel regarding the measures to be taken in case of a hazard, it will be useful for them to save their life before any one comes and help them to come out of the mine.

REFERENCES

- [1] YuLi-min, LiAnqi, SunZheng, LiHui. Design of Monitoring System for Coal Mine Safety Based on Wireless Sensor Network. Mechnronic and Embedded Systems and Applications, 2008. IEEE/ASME International Conference, 12-15 Oct, 2008.
- [2] Yang Wei, Huang Ying. Wireless Sensor Network Based Coal Mine Wireless and Integrated Security Monitoring Information System. Networking, ICN '07 Sixth International Conference, 22-28 April, 2007.
- [3] Mohammad reza Akhondi, Alex, Simon Carlsen, Stig Petersen. Applications of Wireless Sensor Networks in the Oil, Gas and Resources Industries, 24th IEEE International Conference on Advanced Information Networking and Applications, 2010
- [4] Zigbee Alliance Website <http://www.zigbee.org>.
- [5] LPC2148 Datasheet.
- [6] Andrew N.Sloss, Dominic Symes, Chris Wright, ARM System Developers Guide - Designing and Optimizing System Software.