

# Design and Fabrication of Hydro Tech Water Fuel Saver Kit

Kolbe Joy<sup>#1</sup>, Jithin Raj<sup>#2</sup>, Ijas K<sup>#3</sup>, Adarsh Babu<sup>#4</sup>, Rajamani.B<sup>\*5</sup>

<sup>#</sup>Student & Mechanical and Automation Engineering

<sup>\*</sup>Assistant Professor & Mechanical and Automation Engineering

PSN College of Engineering and Technology, Melathidiyoor, Tamil Nadu, India

## Abstract

The objective of this work was to construct a simple innovative hydro tech water fuel server kit generation system and evaluate the effect of hydroxyl gas HHO addition, as an engine performance improver, into gasoline fuel on engine performance and emissions. HHO cell was designed, fabricated and optimized for maximum HHO gas productivity per input power. The optimized parameters were the number of neutral plates, distance between them and type and quantity of two catalysts of potassium hydroxide (KOH) and sodium hydroxide (NaOH). The performance of a Skoda Felicia 1.3 GLXi gasoline engine was evaluated with and without the optimized HHO cell.

**Keywords** — HHO gas, Hydroxy Generation, Hydrogen cell, Exhausts emission, Cell Generator.

## I. INTRODUCTION

With such high demand for more efficient engines, our mission is to design and create a device that will increase engine efficiency without jeopardizing its performance. Such device is an HHO Generator. This generator uses electric current (electrolysis) to yield hydrogen from water. There are two different ways to run the hydrogen into the engine. The first and most ambitious way to this is to send it through the injectors, while shutting off the fuel line. This will only be done if the system is self-sustained, meaning the car is able to run on hydrogen only. We will attempt to make the generator compact and affordable, in order for it to be appealing to customers.

Building this generator comes with some challenges. We need to make sure that the amount of energy put into the cell to split the water molecules is less than the amount of output energy of the generator. In order to overcome this challenge, we will need to make it as efficient as possible. This includes coming up with a creative design to get as much hydrogen out, with the least amount of current running through the cell. Taking these aspects into consideration will make the HHO generator a productive addition to any internal combustion engine.

## II. CONSTRUCTION REQUIREMENTS

The manufacturing of this hydrogen system will require a series of machining. A milling machine is used in order to drill holes on the bottom of the vessel. This is where the tubes are going to be extended out of the container in order to connect the wires for the current. This will allow for the electricity to be outside of the vessel, while the highly flammable HHO gas is stored inside the container, making it safer.

### A. Pulse Width Modulator

Other construction requirements include, making sure the hydrogen gas is well contained to prevent leaks. For this, sturdy hoses or pipes will be used with secured ends. Additionally, no hydrogen will be stored. The engine will consume it almost immediately after the process of electrolysis is completed. Another requirement includes the use of an amp-meter to control the amount of current use to produce the HHO gas, as well as the use of a PWM (pulse width modulator) to adjust the frequency of the current in order to decrease the number of amperes needed for the water breakdown.

### B. Electronic Fuel Injection Enhancer

The most important of the requirements is the implementation of EFIE (electronic fuel injection enhancer), this apparatus is connected between the module and the MAF (mass air flow) sensor of the car. It uses a circuit that allows the driver to adjust the voltage reading manually from the sensor and controls the amount of gas injected in the combustion chamber depending on the driving condition and the amount of gas the produced by the generator. Every car equipped with fuel injection system uses a MAF sensor in order to register how much air is flowing across the air intake manifold to regulate how much gas is needed to produce a perfect mixture.

## III. PROJECT FORMULATION

### A. Projective Objectives

1. Design and build a practical and economical way to increase engine efficiency in combustion engines.

2. Build HHO generator that splits water's molecules, using the process of electrolysis. Yielding a mixture of hydrogen and oxygen gas, also known as HHO gas.
3. Adapt the generator in a conventional internal combustion engine to push the HHO gas either through the injectors, or if the system is not fully sustained with hydrogen, through the air intake to have a mixture of air, hydrogen, and gasoline.
4. Overcome the energy loss that is used in the process of electrolysis with a higher power output by the engine.
5. Try our best to generate hydrogen efficiently enough to have the car run only on HHO gas.
6. If the system is not self-sustained with HHO gas only, then improve its performance and gas millage with such gas. Other font types may be used if needed for special purposes.

#### IV. CONCEPTUAL DESIGN

##### A. Concept Design

An option for the design is to use a Hydrogen (HHO) Generator which can improve fuel economy on any gasoline, Diesel, or LPG vehicle Concept Hydrogen Generator With this innovative Hydrogen on-demand technology you will use less fuel and save money. This kind of HHO generators uses 12-volt batteries to power electrolysis.

##### B. Proposed Design

In electrolysis, people have tried different ways to increase the output of gas while decreasing the input of current. Some designs are more effective than others. Some people have tried to improve the conventional way, called "wet system", consisting on plates or tubes submerged in water, while others have created and developed a design called "dry cell" where the water is constantly running through the plates.

##### C. Wet System

The wet system design is more complicated to manufacture. This design might be more expensive since the steel parts and their arrangement are more challenging to produce. This system uses two different diameter tubes in order to accommodate one inside the other with different polarities, as illustrated in Figure



Fig 1: Wet System

The effectiveness of the wet system is higher than the dry cell system because it allows for bigger metal surface area. Although more current input is necessary, the amount of hydrogen produced is greater. Despite the cost of fabrication of this system and the limited budget, this design has been chosen for the project in order to obtain a better production of hydrogen.

#### V. DESIGN ALTERNATIVE

A wet cell design for the generator that has been chosen, as previously mentioned. Yet, there are two alternative designs of how to feed the HHO gas to the engine. The first is a very ambitious, but plausible design. A hose coming from the generator vessel will be connected to the fuel line while the fuel line will be disconnected. This means the engine will run only on hydrogen and air. However, the amount of HHO might not be enough for the engine to run efficiently.

The alternator has to produce enough amps to recharge the car's main battery as well as a secondary battery that is in charge of sending current to the generator in order for the electrolysis process to happen efficiently. The generator then has to send HHO gas into the engine nonstop in order for the cycle to continue. If at some point of the rotation of the engine is not enough to run the alternator efficiently enough for the cycle to happen, there won't be enough hydroxy gas (HHO gas) to feed to the engine and the car will shut off. One way to fix this problem is to turn the engine into a hybrid by implementing a system that switches between the HHO gas line and gasoline line with the flick of a switch.

If the system is unable to run on hydrogen and without gas, then Plan B comes in play. Plan B is the other way to make use of the generator, which is much simpler. The HHO gas will be fed into the air intake manifold of the engine. The car will run on gasoline all the time, but the mixture of air, hydroxy gas, and gasoline, will improve the combustion cycle, making the engine cleaner and more efficient, since hydrogen is a lot more explosive than gas. The outcome of this design involves more gas mileage and cleaner exhaust gasses. Both alternatives accomplish the goal of environmental friendliness.

#### VI. PROTOTYPE

##### A. Feasibility Assessment

Out of the two alternatives of how to drive the hydroxy gas to the engine, the second alternative is more feasible. Having the gas run into the air intake is cheaper and more achievable. However, testing becomes a big issue with this design, as there would need to be prove of gas millage improvement. On the other hand, the first idea of implementation of the design will require no actual tests as the car will pretty much run only on water. This would be a huge breakthrough for us, the environment, and the automotive industry. However, this will be more

costly and complicated. Both designs will be tried. On the Results section of this report, there will be a section explaining the design that worked as well as a feasibility assessment with more in-depth data in order to compare the total cost of the generator and the gas mileage increase, in order to find a payoff time.

**B. Major Components**

The main component in a Hydrogen-on-Demand system is the HHO or Hydroxy gas generator. This device can be a simple one-cell unit or have as many cells as needed to produce the quantity of HHO gas desired. Electric current is the driving force that creates electrolysis in such generator. It separates chemically bonded compounds in water by passing an electric current through them. By adding an electrolyte to the water, the electrolysis process can be enhanced. An electrolyte is any substance containing free ions that behaves as an electrically conductive medium. Catalyst, would be the correct term because of the function it performs to speed up the production of HHO gas.

Another important component for regulation is the Amp Meter, this is a tool used to measure the amperage flowing through a wire or other conductive material. It is a very important tool for this project, because the number of amps sent to the cell determines the amount of HHO gas generated. Moreover, we need to add an EFIE to the car's ECU to make sure the mixture of air, gas, and HHO are well balanced as well as the use of a PWM (pulse width modulator) to adjust the frequency of the current in order to decrease the number of amperes needed for the water breakdown.

The final major component of our design is a vessel that's big and sturdy enough in which to conduct electrolysis in. It has to be able to maintain high enough pressure of HHO gas to the able to send it through hoses and into the engine's combustion chamber. Furthermore, some machining is need for the vessel. Holes are drilled on the bottom of the vessel to allow for screw.

**C. Structural Design**

The team conducted research to find information about hydrogen generators in general. Many design specifications do not meet our need or standard that we were trying to reach. According to this specific critical research, we need to come up with a better plan and design to meet our efficiency goals.

Many design alternatives were looked at to determine the best way to generate the highest amount of hydrogen possible. The chosen design model will be re-evaluated to seek optimum efficiency. Sizing plays an important aspect of the design, specifically the stainless-steel tubes that will submerge under the water. The optimal tube design has been chosen for this project. An alternative design using parallel plates will also be tested to assure that we have chosen the best design that is suitable for our application.



**Fig 2: Turbo Star Pipes**

**1) Tube Specifications:**

Stainless Steel Grade 316L is used where corrosion resistance and good mechanical properties are primary requirements. This cell generator is built with 12 concentric 316L grade stainless steel seamless pipes and spacers. The outside pipes are 9-1/8" inches long by 3/4" outer diameter and the inner pipes are 10" inches long by 1/2" outer diameter and the wall thickness is 0.035". To connect power (12 v or 24 v battery), negative current is attached to inner tubes and positive current to the outer tubes.

**TABLE I  
AISI 316L Stainless Steel Property**

Property (AISI 316L Stainless Steel)	Value	Units
Elastic Modulus	2.00E+11	N/m <sup>2</sup>
Poisson's ratio	0.265	N/A
Shear Modulus	8.20E+10	N/m <sup>2</sup>
Density	8027	kg/m <sup>3</sup>
Tensile Strength	4.85E+08	N/m <sup>2</sup>
Yield Strength	1.70E+08	N/m <sup>2</sup>
Thermal Expansion Coefficient	1.65E-05	K
Thermal Conductivity	14.6	W/ (m K)
Specific Heat	450	J/ (kg K)
Material Damping Ratio	N/A	

**VII. PROTOTYPE SYSTEM DESCRIPTION**

The chosen design will be a wet cell system. The stainless-steel tubes with a negative charge will be connected to the negative pole of the battery and the positive will be connected to a relay, this will give an on/off control of the system while the car is driven. Moreover, the battery assigned to the cell will not be the same battery of the car. The alternator will be in charge of changing a second battery whose sole purpose is to run the electrolysis process.

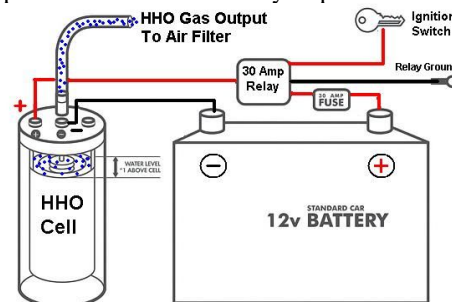

**Fig 3: Hydrogen Generator**

For the connections, 6-gauge battery cables will be used to reduce electric resistance. To avoid all possible losses the vessel should be placed close to the battery. However, the prototype vessel will be too big to install anywhere on the engine compartment. It will be placed in the trunk of the car. Additionally, an amp meter as well as a fuse will be part of the system. This will help monitor the amount of current drained from the vessel, which is a safety precaution as well. All connections are shown in detail in Figure.

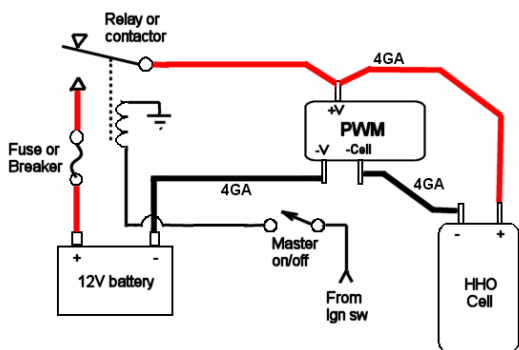

Fig 4: HHO Generator Wiring Schematic

In order to measure the amount of hydroxy gas the generator is producing a flow meter is connected to the output of the vessel. This instrument has a scale from 0 to 5 litres per minute and is used to measure the flow of oxygen (O2). This will be an estimated value since the density of the hydroxy gas is different than oxygen.

**VIII. PROTOTYPE TESTING**

The intension of this thesis is to have the HHO generator power the vehicle’s engine solely on hydrogen gas and not on fuel. The goal is to build up enough pressure on our vessel so that enough hydrogen can be sent to the fuel injectors and eventually shut off the fuel lines. The alternator will have to supply enough charge to recharge two batteries. One is the main battery for the car’s usual electric tasks, while the other one is used solely to send current to the HHO generator. If this is achieved, then there is no real need to make tests for gas millage since the car will run pretty much solely on water. That would be enough prove that our design works properly. If the engine runs without the need of fuel, this would be a big breakthrough for the team and the automotive industry.

However, if the current needed to make enough HHO gas is greater than the current the alternator can produce, then the generator will not be self-sufficient. If this is the case, the generator will be used as a performance enhancer for the engine. The HHO gas will most likely be introduced into the air intake of the vehicle. Now, there would have to be a series of test done to prove that the generator is actually improving gas millage. The test will provide additional proof of the generator’s performance. The car will run with a

full tank without the operational generator and will be driven normally. The number of miles travelled will be recorded. Once a certain number of miles have been driven, it will be filled again and the car will be driven under the same circumstances, this time, with the generator on. Once the same number of miles has been driven, the number of miles travelled and the gallons consumed will be compared with the ones travelled with the generator off.

**IX.MANUFACTURING**

As stated, before it was decided to build a wet system for the prototype. The most challenge part of this design was the setup of the pipes inside the vessel. To accomplish this task, a CAD drawing of the bottom of the vessel was drawn in order to determine the exact locations of the holes to be drilled. To make the holes on the plastic vessel, a CNC machine was used in order to be more precise on their location, this was necessary in order to avoid interference between the tubes allocated inside the vessel.

For the second part of the manufacturing, the main focus was on the outer and inner tubes. A manual lathe was used for cutting, turning and facing of the tubes at the desire measurements. The same lathe was used as a holding fixture for welding the tubes and the carriage bolts in the desire position. These bolts are going to be used for the conduction of current to the tubes.

For the completion of the manufacturing process, it was necessary to seal the holes made on the bottom of the vessel to avoid leaking of water and gas pressure. After arranging the tubes and inserting their corresponding bolts in the desire position, a one-inch layer of resin epoxy was applied inside the vessel. This epoxy, besides closing any opening in the vessel, will help fix the tubes in their position avoiding any kind of movement while the car is running.

**X. ASSEMBLY AND INSTALLATION**

As previously mentioned, this HHO generator was designed in order to fit any kind of internal combustion engine. The installation and wiring of all the instruments and electrical components needed for the generator were made separate from the car. The secondary battery used to feed the generator was also implemented to power up these instruments and other accessories. In order to avoid our secondary battery to run out of power due to the process of electrolysis, a battery isolator was used to get current from the alternator to recharge the battery and to avoid contact to the main battery of the car. For this matter, some re-routing of the car wiring was made. Additionally, the EFIE was installed; this is the most important component to achieve our goal, increase fuel mileage. This apparatus is then connected between the car’s computer and the MAF sensor, for the installation the sensor had to be located and the sending wire from the unit was spliced to conduct the proper connection.



To accomplish “Plan A”, running the engine just with hydroxy gas, installation was very complicated. The fuel rail had to be disconnected from the fuel line to be connected to the new hydroxy gas line, also one of the sides had to be sealed in order to avoid any loses of the gas. At the same time, the fuel pump relay was removed to prevent the pump to work and avoid any leak of gasoline. For “Plan B”, running the engine on gasoline and hydroxy gas at the same time, installation became fairly simple. The hose was connected straight to the air intake manifold.



Fig 5: Finished Generator in Trunk

## XI. HEALTH AND SAFETY CONSIDERATIONS

### A. HEALTH

Hydrogen is the most abundant element in the universe, the first element in the periodic table, and one of the most promising new alternative fuels of the future. The 21st century will be the time of change, end of the widespread use of fossil fuels that have been harming our environment. Fossil fuels, such as coal and petroleum, are the remains of prehistoric organisms buried beneath the earth's surface millions of years ago and they're in limited supply. The reserves of these fuels will eventually vanish by the rate that we are abusing them. Preferably long before we extinguish them, we have to find alternatives. It is important that we find new ways to power our technology. Vehicles that currently use internal combustion engines to burn diesel or gasoline fuel will need to run off of new fuels that are less scarce and burn cleaner, reducing or even eliminating the possibility of pollution and keeping away harmful gasses that can affect consumers' health.

### B. Environmental Impact

Since the industrial revolution started, the environment has experienced some changes which are irreversible. All the exhaust gasses emitted by factories, coal power plants, airplanes, vehicles, etc.

are heating up the planet and are causing the polar caps to melt. Such phenomenon is changing the global temperature of the planet. Scientist predict that by the end of the 21st century the sea level will rise up to 6ft. This will affect about 100 million people that live in cities like Miami. CO2 emissions are accountable for such drastic effects. Another way machinery is affecting the environment is with the uses of substances that contribute to ozone depletion. These usually have high concentrations of chlorine or bromine. Some of these include chlorofluorocarbons, or CFCs, halons, methyl bromide, carbon tetrachloride and methyl chloroform; most of these are used as refrigerants for HVAC systems. It is also aimed to show people an example that young engineers such as ourselves do care for the well-being of earth and humanity in general. The Implementation of one single HHO generator will not help the environment much. However, we are hopeful that devices such as this one will become a trend. Not only they will save people money, but they will help the environment by consuming less gasoline and they will also emit less harmful gasses.

### C. Vehicle Impact

Vehicles consume a lot of energy and use many different fluids including battery acid, motor oil, antifreeze, gasoline, air-conditioning refrigerants, and brake, transmission, hydraulic and windshield-wiper fluids. In most cases, these toxins are harmful to humans and animals, and can pollute waterways if they leak from the vehicle or are disposed incorrectly. Many vehicle fluids are exposed to heat and oxygen while an engine is running, and undergo chemical changes. These fluids also pick up heavy metals from engine wear and tear, making them even more toxic to the environment. There is no question about the damaging environmental effects that are involved with automobiles, and It is our duty as engineers to address these issues.

### D. Safety

Furthermore, tests and installation of the generator will be conducted in a safe place with no flames or flammable materials around. Additionally, team members working on the generator will wear protective gear at all times. The prototype will be seal proved to ensure no hydrogen gas will leak; there will be sealant paste applied to the top cap of the vessel as well as at every hose or pipe connection. When dealing with flammable materials it is important to have a set of safety regulations to abide by. Following all these safety precautions will greatly reduce the chances of a mishap.

## XII. FUEL CONSUMPTION

After the generator was designed, manufactured, and installed a series of tests were performed to obtain quantitative data as to the efficiency of the car with and without the generator. Such data is expressed in the tables below.

TABLE II

MPG without HHO generator			
Run	Gallons	Miles	MPG
1	2.667	52.3	19.610
2	2.727	51.9	19.032
3	2.746	53.2	19.374
4	2.426	49.1	20.239
5	2.597	48.9	18.829
<b>Average</b>	<b>2.6326</b>	<b>51.08</b>	<b>19.417</b>

TABLE III

MPG with HHO generator			
Run	Gallons	Miles	MPG
1	1.918	47.5	24.765
2	2.203	51.8	23.513
3	2.351	55.5	23.607
4	2.025	49.2	24.296
5	2.129	53.6	25.176
<b>Average</b>	<b>2.1252</b>	<b>51.52</b>	<b>24.272</b>

MPG Comparison with and without HHO It was concluded that the car experienced an increase of 4.86 miles per gallon combined (highway and city), going from 19.42 to 24.27 mpg. This is a 25% decrease of fuel consumption, which is an astonishing amount. This shows proof that HHO gas, as an additive to a car, does work and saves the consumer money on their gas expenditure.

### XIII. CONCLUSION

There is a lot of skepticism about HHO generators for vehicles found online. Our final thesis gives valid evidence that, in fact, they do work. It was determined that in order to supplement fuel consumption with hydrogen gas completely, many modifications need to be made to the fuel system of the car, that were out of our reach. Even if these were accomplished, the amount of energy needed for the car to run as well as to power the generator is not enough without the energy coming from the fuel. The hydrogen cell produced oxygen and hydrogen from water through electrolysis. Minimization the cost was done by using wildly available materials. Once Plan A was not successful, Plan B was implemented. From the results of the experiment it can be concluded that having an HHO generator such as this one, will improve gas mileage.

The findings of this senior thesis benefit the environment and society. Since implementing the hydrogen generator will produce less carbon dioxide to the atmosphere, as well as, less consumption in gas. Therefore it will reduce greenhouse gasses. Hence, less effect on global warming on the long run. Moreover,

since implementing a hydrogen generator will provide more fuel efficiency, it will save money for people who will use our product. It is hard to tell if the generator will continue to be as efficient in the long run, because we couldn't take into account alternator wear or battery productivity. However, with regular checkups these factors can be taken care of.

The process to design and manufacture was a little tedious, as we needed to do research on the different types of electrolysis and HHO generators. Many times, we encountered people claiming that such generators are not efficient and that, in fact, they are a myth and don't work. This was kind of discouraging sometimes. But we kept working through with the intention of showing proof of their effectiveness. We were very pleased when we acquired the results showing an improvement in gas mileage. As engineers, we felt accomplished to know that such device can help alleviate some of society's biggest issues.

### REFERENCES

- [1] Verhelst S, Wallner T. Hydrogen-fueled internal combustion engines. *Prog Energy Combust Sci* 2009; 35:490e527
- [2] Boretti B. Advances in hydrogen compression ignition internal combustion engines. *Int J Hydrogen Energy* 2011;36: 12601e6.
- [3] Electrolysis. Chemistry Purdue <http://www.chem.purdue.edu/gchelp/howtosolveit/Electrochem/Electrolysis.htm>
- [4] Calvert, James B. (2008-04-21). "Hydrogen". University of Denver. <http://mysite.du.edu/~jcalvert/phys/hydrogen.htm>
- [5] Stan Meyer's Water Fuel Cell. <http://www.waterfuelcell.org/>
- [6] Public Health: Fossil Fuel Collateral Damage, August 2013.
- [7] What Are the Dangers of Hydrogen-Powered Vehicles? July 2011. <http://auto.howstuffworks.com/fuelefficiency/alternative-fuels/hydrogen-vehicle-danger.htm>
- [8] College of the Desert in Palm Desert, California, titled: Hydrogen Use in Internal Combustion Engines. December 2001. [http://www1.eere.energy.gov/hydrogenandfuelcells/tech\\_validation/pdfs/fc\\_m03r0.pdf](http://www1.eere.energy.gov/hydrogenandfuelcells/tech_validation/pdfs/fc_m03r0.pdf)
- [9] US Department of Transportation, Federal Highway Administration, 2011. <http://www.fhwa.dot.gov/ohim/onh00/bar8.htm>
- [10] Jennifer King, Demand Media. How Does car Pollution Affect the Environment and Ozone Layer <http://homeguides.sfgate.com/car-pollution-affect-environment-ozone-layer-79358.html>?
- [11] Jadhav Shashikant, Gabhane Darshan and Deshmukh S.S 2016 Investigating the Effect of Oxy-Hydrogen (HHO) gas and Gasoline Blend Addition on the Performance of Constant Speed Internal Combustion Engines *International Engineering Research Journal* 26-31
- [12] Bambang Sudarmanta, Sudjud Darsopuspito, and Djoko Sungkono, "Application of Dry Cell HHO Gas Generator with Pulse Width Modulation on Sinjai Spark Ignition Engine Performance", *International Journal of Research in Engineering and Technology* Volume: 05 Issue: 02. (2016)