

CHECKING HOSPITAL REPORTS VIA BIOMETRIC AUTHENTICATION FOR ACCIDENT VICTIMS USING IOT

Mr.V.MATHAN KUMAR,Mr.S.RASEEN AHAMED

FINAL YEAR, INFORMATION TECHNOLOGY,

PAAVAI ENGINEERING COLLEGE, NAMAKKAL, TAMILNADU, INDIA

Mr.B.VENKATESAN M.E.,(PhD.),Head of Depatrmnt

Mrs.M.BABYLATHA M.E.,ASSISTANT PROFESSOR,

INFORMATION TECHNOLOGY,

PAAVAI ENGINEERING COLLEGE, NAMAKKAL, TAMILNADU, INDIA

Abstract

In the Healthcare industry, when it comes to Patient Safety and Security, the most debated and talked about subjects are Patient Identification and Patient Data Integrity. Fingerprint Recognition Technology has become part of our daily lives. Few of its most common uses are, timekeeping systems for payroll purpose and Smart-phones with the ability to identify users based on their finger prints. In the similar lines, some of the hospitals are exploring the use of fingerprint scanners. The approach has both benefits and drawbacks. Since the biological pattern found in the fingerprints of every individual is unique and permanent, the use of fingerprint biometrics would provide to be a

reliable and accurate method to efficiently identify the patients. The best part of the fingerprint technology is that apart from safeguarding the patient's information, it also protects against fraud and minimizes human intervention. Such use of this technology minimizes the need to enter new information into patients' records, limiting the human element involved with data entry. Thus making it easier to match the patients' records for his/her future visits. Organizations using the Fingerprint Recognition Technology mostly use the fingerprint scanners. Simply by placing a finger on a self-service kiosk or other reading device, the enrolled patients get registered quickly at the entry point of any

facility, like the emergency department,

inpatient areas or outpatient locations.

Keyword:, Biometric Security, IoT System, Microcontroller, WIFI Module

Introduction

The proposed project has a two layers of protection the first layer of protection is a Fingerprint recognition, based on which the vehicle locks are opened. The Fingerprint matching is done by utilizing the details based stored database using Fingerprint recognition scheme. The second layer of protection is the convention method to use keys. This provides a fine combination of “Biometrics technology” and “Embedded system technology”. Fingerprint sensor is the main part of this system. It makes use of Biometric sensor to detect fingerprint. It is also called as Biometric sensor. Fingerprint sensor uses various types of techniques like ultrasonic method, optical method or thermal technique. In this project we have used optical fingerprint sensor. The main feature or specialist of fingerprint is that it is unique. It gives this project the high level security than other security systems. An accident is a specific, unexpected, unusual and unintended external action which occurs in a particular time and place, with no apparent and deliberate cause but with marked effects. In most of the accident cases, the victims lose their lives because of

the unavailability of medical facilities at the right time this is because the information about the accident occurred person is not known to immediately.

Proposed system

The Biometric characteristics of each and every individuals dwelling in the globe along with their personal details like name, address, contact number and parents details would be feed into centralized database server. In case of any accidents the health care centers make use of BMAD, obtains the biometric patterns and feed the obtained patterns into common proposed Website, which in turn connected with centralized database server. The obtained biometric pattern would be matched with the existing biometric pattern of database, If the Biometric patterns matches ,the centralized server displays the details about the individual (with his/her family members contact numbers) to the health care centre’s through which the request for individual identity were been made. The Health care centre’s as to take of the responsibility for alerting the family members of the

individual, whom had met with an accident through SMS services or through a phone call.

Block diagram for proposed system

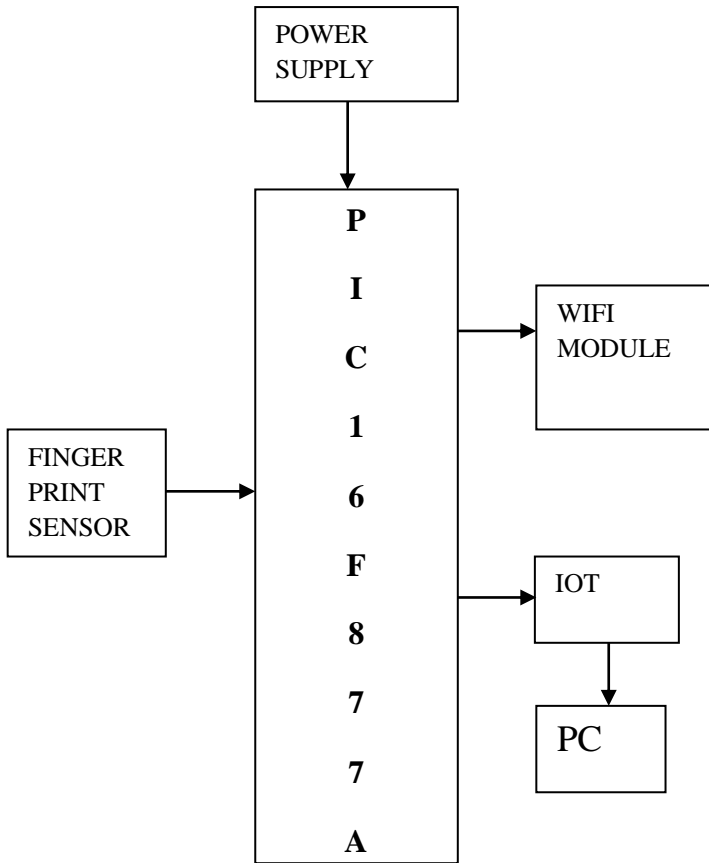

Working methodology

The scanner uses a light-sensitive microchip (either a CCD, charge-coupled device, or a CMOS image sensor) to produce a digital image. The computer analyzes the image automatically, selecting just the fingerprint, and then uses

sophisticated pattern-matching software to turn it into a code. A fingerprint matching module computes a match score between two fingerprints, which should be high for fingerprints from the same finger and low for those from different fingers. As biometric technology expands in law enforcement, the science of biometrics has been developing approaches that can be used to automatically and accurately identify individuals by personal characteristics including fingerprints, palm, vein, voice, face, iris and DNA. The patient information send the doctor from IOT communication.

Applications

This system used in hospital application for emergency purpose and also used in police station to identify the unknown people from accidents

Conclusion

In upcoming future, if the system proposed comes to real time existence, it saves time in medicinal centre and it highly reduces complexity of identifying individuals during critical emergencies like accidents, death and so on. This system provides accurate information about an

individual, whenever in need and it is universally accepted.

References

- D. Munro, —New Study Says over 2 Million Americans Are Victims of Medical Identity Theft - Forbes. [Online]. Available: <http://www.forbes.com/sites/danmunro/2015/02/23/new-study-says-over-2-million-americans-are-victimsofmedical-identitytheft/#640dcc93702d>. [Accessed: 18-Aug2016].
- L. Shin, —How biometrics could improve health security, Fortune, Feb-2015.
- D. Borthakur, —HDFS architecture guide, Hadoop Apache Proj. <http://hadoop.apache.org> ..., pp. 1–13, 2008.
- Jayanthi, —7 celebrity data breaches: When employees snoop on high-profile patients, Beckers Health IT and CIO Review, 2015. [Online]. Available: <http://www.BeckerShospitalReview.com/healthcareinformationtechnology/7-celebritydata-breaches-when-employeesnoopon-high-profile-patient.html>. [Accessed: 19-Aug-2016].
- M. Alam and K. A. Shakil, —Cloud Database Management System

Architecture, UACEE Int. J. Comput. Sci. its Appl., vol. 3, no. 1, pp. 27–31, 2013 ➤

<http://www.iritech.com/blog/internet-of-things-1016>

➤ ”THE BIO-T: THE BIOMETRIC INTERNET OF THINGS” GEORGE AVETISOV, CEO AND CO-FOUNDER, HYPR CORP. NOVEMBER 11, 2016

➤ “Biometrics to Secure the Internet of Things”, <https://www.engadget.com/2015/10/08/biometrics-to-secure-the-internetof-things>.

➤ ” The Internet of things”, Gershenfeld N, Krikorian R, Cohen D (2004). Sci Am 291(4):76–81

➤ “Biometrics in Internet of Things (IoT) security” Published on September 26, 2016 Narsimhaswamy badugu, <https://www.linkedin.com>

➤ G. Santucci. From Internet to Data to Internet of Things. Proceedings of the International Conference on Future Trends of the Internet. (2009).