

# Analytical study On Flexural Behaviour Of Reinforced Geopolymer Concrete Beams

Mr.M.Gokulakrishnan,  
PG Student  
Structural Engineering,  
Thiagarajar college of Engineering, Madurai,  
e-mail: gokulakrishnan.mgk@gmail.com

Ms.A.Dhanalakshmi,  
Assistant Professor,  
Civil Engineering Department,  
PSR Engineering College, Sivakasi,  
e-mail: asiadhanam93@gmail.com

**Abstract:** This paper focus on analytical investigation carried out on reinforced geopolymer concrete with fly ash. Geopolymer concrete is proven to have an excellent engineering properties with reduced carbon footprint. It not only greenhouse gas emission but also utilize large amount of industrial waste material such as fly ash. If structure have a minimum cover thickness, concrete spalling and corrosion of reinforcement occurred in the structure. Due to this reason, the element life is reduced and also the structure will be collapsed. To rectify this problem, we are using geopolymer concrete, and it is used to improve the element life. Using the past experimental results, the various parameters like young's modulus, stress, strain and Poisson's ratio are given as an inputs to the beam model which has been created in ANSYS 15.0. From the experimental and analytical results, the maximum deflection and load deflection response are compared. In this project, various cover thickness of beam is provided like 20mm, 25mm and 30mm.

**Keywords - Geopolymer concrete, Fly ash, Sodium Silicate, Sodium Hydroxide, ANSYS.**

## 1. INTRODUCTION

Geopolymer concrete was first introduced by Joseph Davidovits (1978). Davidovits Proposed that an alkaline liquid could be used for the reaction with silicon and aluminium in a source material of geological origin like kaolinite, clays or in a by-product materials such as fly ash, silica fume, slag, rice husk ash, red mud, etc. The chemical reaction takes place in this case called Polymerization process and therefore he stamped the term 'Geopolymer' to represent the binders.

There are two main constituents namely Source materials and alkaline liquids. For geopolymer, the source materials based on alumina-silicate should be rich in silicon (Si) and aluminium (Al). The alkaline liquids that are normally based on sodium or potassium which are soluble alkali metals. In geo polymerization, the most common alkaline liquids are the combination of sodium hydroxide or potassium hydroxide and sodium silicate or potassium silicate.

Geopolymer are used in many fields due to their various properties of high compressive strength, low shrinkage, acid resistance, fire resistance and high durability. Studies of most of the Geopolymer concrete are done under heat cured regime. At the temperature ranges from 60°C to 90°C for 48 hrs, the polymerization process is fast.

## 2. REVIEW OF LITERATURE

### 2.1 Geopolymer Concrete with Fly Ash:

A Lloyd and B V Rangan, they concluded that geopolymer concrete results from the reaction of a source material that is rich in silica and alumina with alkaline liquid. Test data are used to identify the effects of salient factors that influence properties of the geopolymer concrete and to propose a simple method for the design of geopolymer concrete mixtures.

*Ambily et.al.*, (2011) presents the experimental and analytical investigations on shear behaviour of reinforced geopolymer concrete beams is detailed Geo polymer materials are inorganic polymers synthesized by reaction of a strongly alkaline silicate solution and an alumino silicate source. Geo polymer is used as binder to completely replace the ordinary Portland cement in producing Geo polymer concrete (GPC). They possess the advantages of rapid strength gain, elimination of water curing, good mechanical and durability properties and are additional ecofriendly and sustainable alternative to Ordinary Portland Cement (OPC). While substantial research work has been reported on behavior of reinforced concrete structural elements, similar studies have not been reported on GPCs. This paper describes an experimental and analytical investigation on shear behavior of reinforced GPC and OPCC beams. The aim is to study the shear behavior of reinforced GPC and OPCC beams. Three GPC mixes and one OPCC mix were considered for the study. All the beams were provided with the same flexural and shear reinforcement and the beams were tested under two point loading with two shear span to depth ratios of 1.5 and 2 for each of the mixes of structural behavior with respect to cracking, service load, deflections at various stages and failure modes. Comparison of shear design procedure of beams was made by conventional IS 456 2000 approach and Modified compression field theory. Non linear finite element analysis of beams by 3D modelling of concrete and discrete modeling of reinforcement. The load shear capacity, load deflection characteristics and failure

Modes and crack patterns obtained from the experimental and analytical study were compared for both RPCC and RGPCC beams. The results of the study indicate that the performance of RGPC is similar to that of RPCC beams and the ultimate loads are in the same order. The failure modes and crack patterns are also similar.

**Shaishav et al.**, investigated the comparative study of experimental and analytical results of FRP strengthened beams in flexure. This paper presents the nonlinear Finite Element Analysis (FEA) that has been carried out to simulate the behavior of failure modes of Reinforced Concrete (RC) beams strengthened in flexure by Fiber Reinforced Polymer (FRP) laminates. Two beams were modeled in FEM software using ANSYS. In those two beams, one beam is control beam without FRP and other beam is Glass Fiber Reinforced Polymer (GFRP) strengthened beams. From the analyses the load deflection relationships, crack pattern, first crack load and Ultimate load was obtained and compared with the experimental results available in Literature. There was a difference in behavior between the RC beams strengthened with and without GFRP layers. Therefore, modeling of experimental beams can be adoptable in ANSYS. Validation of experimental results can also be done using ANSYS.

**Sri Kalyan et al. (2017)** investigated the analytical study on fly ash and ggbs blended reinforced geopolymer concrete beam by using ANSYS. Concrete, artificial engineering material made from a mixture of Portland cement, water, fine and coarse aggregates and a small amount of air. It is the most widely used construction material in the world. Concrete is the only major building material that can be delivered to the job site in a plastic state. This unique quality makes concrete desirable as a building material because it can be molded to virtually to any form or a shape.

Concrete provides wide latitude in surface textures and colors and can be used to construct a wide variety of structures such as highways and streets, bridges, dams, large buildings, airport runways, irrigation structure, break waters, piers and docks, sidewalks, soils and farm building homes and even barges and ship. Other desirable qualities of concrete as a building material are its strength, economy and durability. Depending on the mixture of materials used, concrete will support, in compression, 700 or more kg/sq cm, (10,000 or more lb/sq cm) ANSYS, Analyzing Software, has been used in this project. ANSYS Mechanical software is a comprehensive FE analysis (finite element) tool for structural analysis, including linear, nonlinear and dynamic studies.

The engineering simulation product provides a complete set of elements behavior, material models and equation solvers for a wide range of mechanical design problems. In addition, ANSYS Mechanical offers thermal analysis and coupled-physics capabilities involving acoustic, piezoelectric, thermal-structural and thermo-electric analysis. The ANSYS Mechanical software suite is trusted by organizations around the world to rapidly solve complex structural problems with ease.

**Karthik, et al (2017)** discussed about analytical study on fibre reinforced geopolymer concrete. This paper focuses on the Experimental and Analytical Investigation carried out on fibre reinforced Geopolymer concrete with Fly ash and GGBS, glass fibre and steel fibre. Geopolymer concrete is proven to have excellent engineering properties with a reduced carbon footprint. It not only reduces the greenhouse gas emissions (compared to Portland cement based concrete) but also utilizes a large amount of industrial waste materials such as fly ash and slag. In addition to geopolymer, fibre addition was seen to enhance the tensile strength. The experimental

investigation of steel fibre reinforced concrete and glass fibre reinforced concrete was done by compression test and young's modulus was calculated. An analytical study was done using ANSYS V12.0 with the modulus of elasticity found from the experimental result.

**Uma et al., (2012)** investigated the experimental investigation and analytical modeling of reinforced geopolymer concrete beam. This paper presents the flexural response of Reinforced Geopolymer Concrete (RGPC) beam. A commercial finite element computer program ANSYS 12.0 has been used to perform a structural behavior of RGPC beam. Using various parameters like stress, strain and Poisson's ratio obtained from experimental results, a model has been created in ANSYS 12.0. Experimental based analysis has been widely used as a means to find out the response of individual elements of structure with reinforcement ratio of 0.87% and 1.75% for grades M20, M25, M30 and M35 with companion specimens like cylinders. The results from both ANSYS 12.0 modelling and experimental data were compared.

The observation was mainly focused on RGPC beam behavior at different points of interest which were then tabulated and compared. Due to high stiffness of reactive geopolymer concrete, the actual deflections of the beams were found to be slightly low allowable values under service loads. In ANSYS 12.0 the deflection obtained was found to be low due to meshing of elements in the modeling. The comparative result gives 20% difference for experimental and ANSYS 12.0.

**Yoursry et al., (2017)** investigated the Structural behavior for rehabilitation ferrocement plates previously damaged by impact loads and find out the possibility of using ferrocement concrete to rehabilitate the damaged plates which failed under impact load. The current work prevents the comparison between the results of first crack loads, the ultimate loads and the deflection in the cases of the impact is static loads. Seventeen plates were damaged under impact load which having the dimension of 500x500 and 25 mm thick. The plates were subjected to impact load by 1.15 Kg spherical steel ball under its height 1.12m at the centre of the tested plates. The ferrocement plates were reinforced with skeletal steel bars welded galvanized meshes and expanded steel members with skeletal steel bars. The plates were tested up to failure. The rehabilitation of plate were tested simply supported along its four sides and subjected to central flexural loadings until failure. The obtained results reached emphasized good deformation characteristics, high first crack and ultimate load and cracking pattern without spalling of concrete cover that is predominant.

**Arash Behnia et al., (2017)** investigated the fracture Characterization of Multi-Layer Wire Mesh Rubberized Ferrocement Composite Slabs by Means of Acoustic Emission. The fracture behavior of multi-layer ferrocement composite slabs with partial

replacement of tire rubber powder as filler utilizing Acoustic Emission (AE) technique for characterization. Ferrocement slab specimens prepared using normal-compact cement mortar, self-compact cement mortar, fly ash, and rubberized self-compact cement mortar with varying steel mesh reinforcement layers– were statically loaded to failure. The inclusion of 10% rubber powder (by weight) was found capable of altering the failure mode of composite slabs from brittle to ductile with a slight reduction in the ultimate flexural strength. Fracture development of the specimens was closely monitored using AE for enhanced characterization. It is seemingly evident that the measured AE parameters could be effectively processed to distinguish different modes of fracture. The collected AE data was utilized to quantify stiffness reduction in the specimens due to progressive damage.

**Mahmoud A Wafa et al., (2010)** investigated the characteristics of ferrocement thin composite elements using various reinforcement meshes in flexure. The study include the effect of the various kinds of reinforcement meshes (stainless steel meshes and E-fiberglass meshes); number of mesh layers and various mesh diameters with opening size as well as various kinds of mortar materials as matrix. The results clarify the use of stainless steel meshes as reinforcement system in the ferrocement thin composite elements contributes significantly to the improvement of bending characteristics in terms of first crack load, bending stiffness, ultimate flexural load, energy absorption to failure and numerous fine and well-distributed cracks with a smaller width than while using fiberglass meshes. The results obtained using this method are compared with the experimental results.

### 3. GENERAL

In this paper, modeling of beam was done virtually by using finite element software ANSYS 15.0, the results are compared with the control specimen. Various steps involved in the generating a models and further processing were mentioned in this paper.

### 4. DESCRIPTION ABOUT THE SOFTWARE

ANSYS is an analysis software across a range of disciplines including finite element analysis, structural analysis, computational fluid dynamics, explicit and implicit methods and heat transfer. The ANSYS MECHANICAL is a finite element analysis tool for structural analysis including linear, non-linear and dynamic studies. This computer simulation provides finite elements to model behaviour, and support material models and equation solvers for a wide range of mechanical design problems. ANSYS Mechanical also includes thermal analysis and coupled-physics capabilities involving acoustics, piezoelectric, thermal-structural and thermo-electric analysis. ANSYS workbench (Mechanical) is more graphics focused and geometry focused. There is less direct connection to the FEM. Workbench provides easy to learn, easy to use environment. The ANSYS Workbench environment is an intuitive up-front finite element analysis tool that is used in conjunction with CAD systems and/or design modeler.

### 5. ANALYTICAL STUDY OF BEAMS

The above mentioned steps were explained in a detailed manner below with the data obtained from the experimental values and the same is validated with that of the analytical part with comparison of effective cover of 20mm and 25mm normally experimental analysis is done to study the individual component

response and the strength of concrete under various loading conditions. This method shows the actual response of the structure but it is expensive and time consuming. To minimize that difficulty, the finite element analysis is an effective tool for the evaluation of structures and to find the response of structures by giving almost accurate results under various loading conditions. By taking the advantage of the symmetry of the beam and loading, one quarter of the full beam was used for finite element modeling. This approach reduces computational time and computer disk space requirements significantly.

### 6. ELEMENT TYPES

ANSYS literally provides hundreds of element types. To identify these element types, each element. By default the workbench automatically chooses appropriate element types from an element library according to the type of structural bodies involved in the project.

### 7. LOADING AND BOUNDARY CONDITION

As an 1/3 length of loading was applied on the beam of 500 KN. The support conditions were given to the Beam specimen by both side of simply supported condition is given. The displacement of reinforcement was given only in Z direction.

### 8. MATERIAL PROPERTIES

For FEA analysis the following properties of concrete were given in the engineering data section for further solving., i) Compressive strength , ii) Elastic Modulus , iii) Poisson’s ratio and iv) Density. For each type of specimen the values of the above said properties except young’s modulus had been found out experimentally and were provided in the required field.

### 9. GEOMETRY OF THE GPC BEAM

The geometry of the geopolymer concrete beams is 3200mm x 400mm x 230mm. Beams are simply supported on both the sides and two concentrated load is applied at 1000mm from the support. M25 grade concrete is used for various covers of 20, 25 and 30mm.

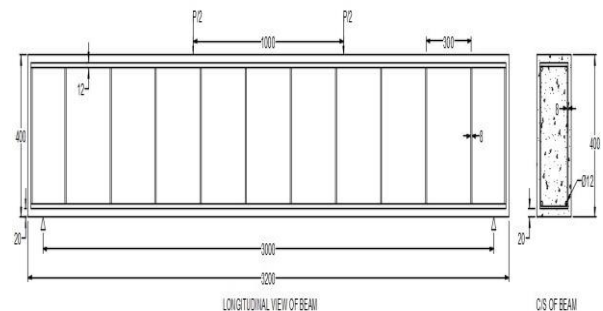

Fig.1 Beam Geometry

10. FE MODELING OF REINFORCED BEAM

While modeling the specimen in beam of 230x400x3200mm was considered. In the modeling process, two different parts were modeled combine and then bonded together. The concrete surrounding the reinforcement bar was combine 4modeled and embedded reinforcement of the beam. The parts modeled combine for main reinforcement, stirrups, cover thickness and concrete. To resemble the experimental scenario, steel bar of both 12mm diameter and stirrups 8mm diameter. The length of the beam is 3200mm was modeled. After successfully giving thickness the model was meshed. The meshed specimen model to obtain precise results, in concrete vicinity of reinforcement, meshing was done much finer at the interface between concrete and reinforcement. A total of four specimens were modeled as that of the analytical work.

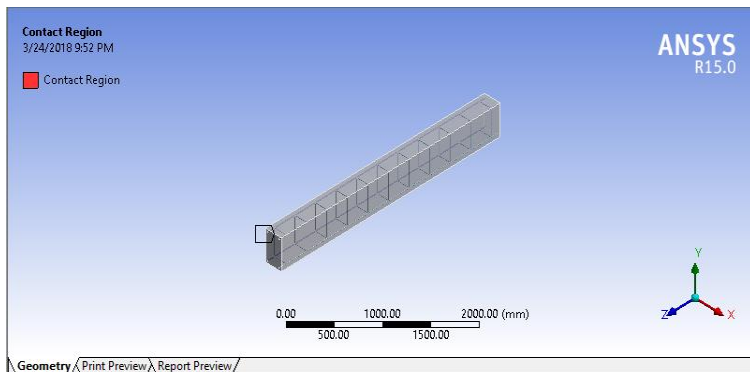

Fig.1. Modelling

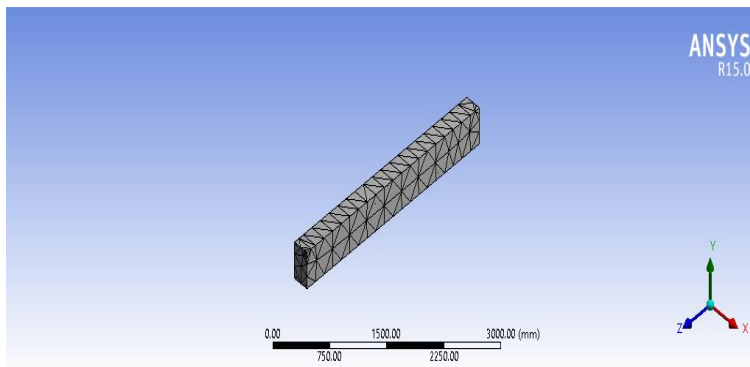

Fig.2. Meshing

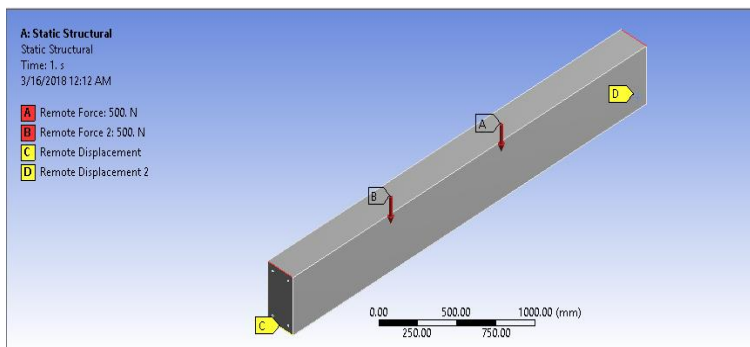

Fig.3. Loading Condition

7. Coordinate System.

Object Name	Global Coordinate System
State	Fully Defined
<b>Definition</b>	
Type	Cartesian
Coordinate System ID	0.
<b>Origin</b>	
Origin X	0. mm
Origin Y	0. mm
Origin Z	0. mm
<b>Directional Vectors</b>	
X Axis Data	[ 1. 0. 0. ]
Y Axis Data	[ 0. 1. 0. ]
Z Axis Data	[ 0. 0. 1. ]

8. Specification of elements of slab panel

Description	Specification
Beam size	3200 X 400 X 230mm
Diameter of Reinforcement	12mm, 8mm.

9. RESULTS AND DISCUSSIONS

The fibre reinforced geopolymer concrete beam was successfully modeled and the load deflection curve can be obtained by varying the cover thickness and retrieving the corresponding deflection. The maximum deflection obtained for the ultimate load of 500kN for 20mm cover is 0.028, for 25mm cover is 0.029 and for 30mm cover is 0.03mm.

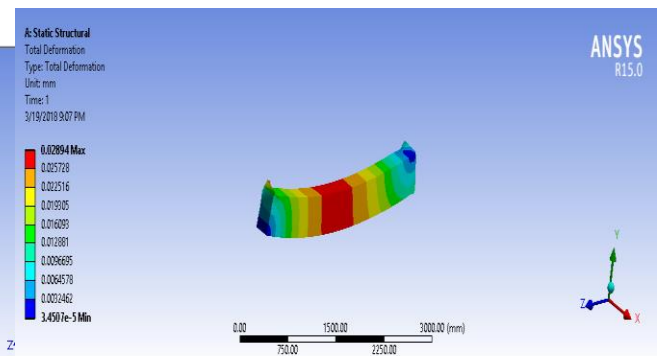

Fig.4. Deflection for 20mm Cover

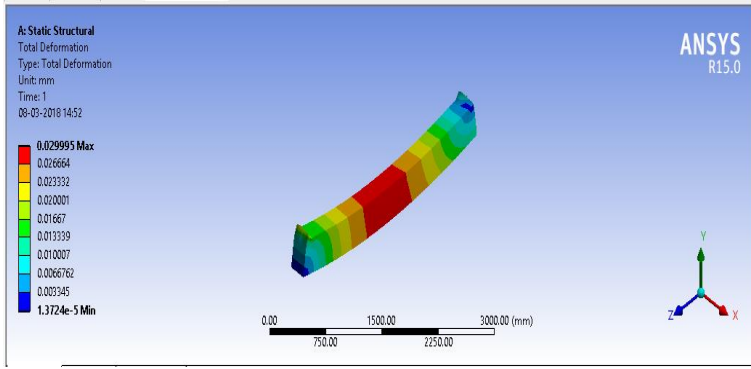

Fig.5. Deflection for 25mm Cover

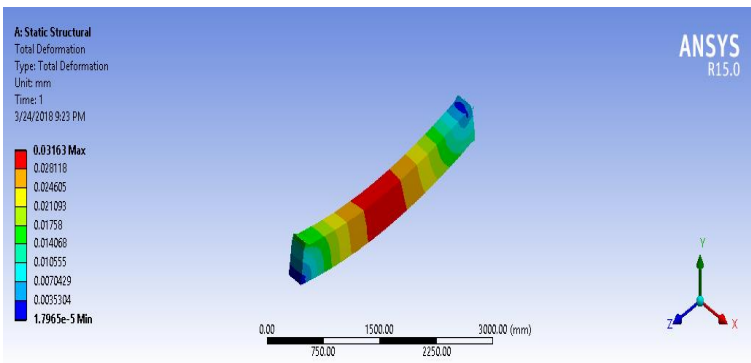

Fig.6. Deflection for 30mm Cover

### 10. CONCLUSION

As per IS code 25 mm cover is provided for beam. In this project for various cover thickness provided to check for the deflection for the beam.

1. Analytical result show that 30mm cover thickness of beam is having higher deflection.
2. 20mm cover thickness of reinforced geopolymer concrete beam shows less deflection.
3. 25mm cover thickness is adopted for the beam is more effective.

### References

[[1]. Karthik M. P, Arul Gnanapragasam A., Sree Vidya V., Ragul K., Robert Ravi S., Rex J.”Analytical Study On Fibre Reinforced Geopolymer Concrete”.

[2]. Darmansyah Tjitradi, Eliatun Eliatun, Syahril Taufik “3D ANSYS Numerical Modeling Of Reinforced Concrete Beam Behavior Under Different Collapsed Mechanisms”.

[3]. Shaishav R. Viradiya, Tarak P. Vora “Comparative Study Of Experimental And Analytical Results Of Frp Strengthened Beams In Flexure”

[4.] B. Sri Kalyan, Dr.J. Guru Jawahar, C. Sreenivasulu “Analytical Study On Fly Ash And GGBS Blended Reinforced Geopolymer Concrete Beams By Using Ansys”

[5]. Jammi Nagraj And Mendu Uday Bhaskar “Geopolymer Concrete Beam Analysis By Ansys Software”

[6]. Deepthi .V ,Dr Sabeena M .V “Experimental And Analytical Study On Bond Performance Of Reinforced Bars Embedded In Fibre Reinforced Concrete”

[7]. Experimental Validation Of Geopolymer Concrete Beams Using Finite Element Analysis

[8]. A.M. Malek ,H. Saadatmanesh “Analytical Study Of Reinforced Concrete Beams Strengthened With Web-Bonded Fibre Reinforced Plates Or Fabrics”

[9]. C.C. Spyrakos, I.G. Raftoyiannis , L. Credali And J. Ussia “Experimental And Analytical Study On Reinforced Concrete Beams In Bending Strengthened With FRP”

[10]. Malek, Amir Masoud “Analytical Study Of Reinforced oncrete Beams Strengthened With Fiber Reinforced Plastic Plates (Fabrics)”