

GESTURE BASED ASSISTANCE SYSTEM FOR APHASIA PATIENT

¹R.JAYASREE, ²M.AISWARYA, ³R.DEEPA
⁴G.DHANALAKSHMI

1, 2, 3, UG Scholar, Department of Electronics and communication Engineering, Sri Ramakrishna Engineering College
Coimbatore, Tamilnadu, India

4, Assistant Professor ECE/ [Sr.G] ECE, Department of Electronics and communication Engineering, Sri Ramakrishna Engineering College
Coimbatore, Tamilnadu,India

E-mail-ids: 1jayasree.1402049@srec.ac.in, 2aiswarya.1402060@srec.ac.in, 3deepa.1402061@srec.ac.in,
4dhanalakshmi.g@srec.ac.in

ABSTRACT

Normal Human being is able to see and interact with the surroundings. Every individual are not blessed with this criteria. Minority of the people tend to lose their vocal cord in an accident. Such type of patient is known as 'Aphasia Patient'. The communication mannerism of aphasia patient doesn't coincide with the normal people. This project is to provide support for aphasia people by recognising their gestures and converting into its corresponding audio language. India is been developing in to the digitalized technology, so the difficulty can be overcome by the newly systems. The learning of the gestures postures differs from each individual, which may also lead to a wrong understanding of the conversation. This difficulty has to be overcome, in order to make the patient to live in a betterment life. The mute language is changed into the speech by the digital signal recognition method. The glove includes 4 flex sensors that gain the pressure produced in the fingers, GSM module to transfer the message for a particular cellular, IR sensor to control the objects in the room, LCD to show off the signs as the text message and a speaker that increases the amplitude of the gesture language. Initially, Flux sensor working is performed and result is identified. The performance of the sensor is up to 85%. The working of flux sensor could be improved.

Keywords: Aphasia patient; digitalised world; data glove; GSM system; IR sensor;

I. INTRODUCTION

Unexpected things happen at unexpected situation. Accident is one among them. In a sudden matter of time accidents may occur and are not expected at the moment. It may also tip to lose the vocal cord in the course of uncertain situation. The people who lose their vocal cord are known as 'APHASIA' people. Recovery from the situation is not so an easy process. The Primary difficulty faced by them at this stage is they cannot share their ideas. There the interaction between the normal people and the patient is affected, which may lead to reduce their communication and inbuilt a low self-esteem. Communication with aphasia patient is important in order to know their feelings. Normal people will face difficulty for simultaneous converse with these people. Then, gesture is the only mean through which speechless conversation will happen. It is the route through which sharing of the information or the current

situation takes place. Gesture is an expression which harvests meaningful activity of the physical movement of fingers.

"Actions speak much louder than the words". Mental state could be found only by means of expression made. Recognising the gesture is an art that cannot be cultivated by all individuals. These languages are not universe and they vary from each location to location. Many languages that are used for conversation in the world are equally puzzled to the sign languages. Cultivation of each language is difficult because it possess different shapes. Gesture recognition is normally done by physical activity or the facial expressions that produces the thoughts of individuals. Analysis differs for every individual. Each categorizes the expressions in their track of behaviour, which would be a tricky part for capturing the actual action emerging from the finger. The interpretation of the data also varies from individuals to individuals. Wrong identification of the indicators provided by the mute people may mislead the direction of views provided. If the message is inferred in a different manner it may also lead to issues at utmost level. The conversation between the mute and normal human beings mostly takes place through signs and the mute recognise it through the vision power [1]. Always it is not possible to find a Translator or an intermediate for the sign language translation. Learning the gesture denotation at the spirit is not so easily for all the livings.

Researchers show keen interest in developing methods for mute people. The ways of methods varies accordingly with the researchers. In order to overcome this hectic situation data glove is invented. This glove converts the action into the speech signal. This is possible by capturing the curvatures and the angles made with the fingers. Each math values produced by the finger bends could be different. The variations provided are recognised and the corresponding action is specified. [2].

Social awareness should be created to help the physically aided person. According to the statistics around 9 billion populaces in the world are deaf and dumb. In India about 40-80 million people are disabled. Due to rise in traffic accidents and age related disabilities in the approaching years the number of disabilities is increasing. In OECD countries high disable rate are noted. In 2011 census, out of 121cr population, about 2.68 are disabled which is 2.21% of the total population. The Proportion reported is 57-58 % of males and 42-43% of females. Among different disabilities 48.5 % emerges for the blind as the top category, in the fourth coming the

percentage for the tone-deaf and dumb is about 7.5%. India is in the on-going process to develop progressive policy for the disability rights movements. Newer thinking and better synchronisation is the required by the government.

The work about this paper is to facilitate the patient by converting the sign into speech language. The speech is also converted into text which is send as SMS to the specific phone number. As everyone is not educated a Speaker is provided to increase the frequency level of the voice by using a speaker in the home. IR sensor is also used in order to control the nearby objects.

II. LITERATURE SURVEY

Deaf mute Communication Interpreter [3]: This paper uses different methods like wearable communication device and Online Learning System to satisfy the mute people. They use Glove depend system, keypad method and handicom Touch screen as the types under the wearable. Online Learning is the method to interpret the external information that can be attached to it.

An Efficient Framework for Indian Sign Language Recognition using Wavelet Transform [4]: It proposed ISLR system: features extraction and classification. Sign language recognition is done by the Discrete Wavelet Transform based on the extraction of features and nearest neighbour classifier.

Hand Gesture Recognition using PCA [5]: The Paper Proposed a database based on the colour of the skin model approach and the matching component thresholding the value. This could be situated used for the Human Robotics applications. The hand section is segmented into by applying YCbCr skin colour model .Next stage is thresholding to separate the regions. Finally, Matching is done with Main Factor Analysis.

Hand Gesture Recognition System for Dumb People [6]: Digital image processing system is used for static hand gesture acknowledgment. SIFT algorithm is used for hand gesture features. SIFT features has been computed at the edges which are invariant to scaling rotation, addition of noise.

An Automated System for Indian Sign Language Recognition [7]: On the origin of shape this paper is proposed for spontaneous recognition of signs feature. Otsu's thresholding algorithm is mainly for the partition of hand region. It chooses an optimal threshold to minimise the same variations of the grey scale pixel. *HU's* invariant moments are served to artificial Neural Network to find the feature of partitioned hand region. Accuracy is based on the Sensitivity and Specifications.

Hand Gesture Recognition for sign Language Recognition [8]: Sign language is the solitary mean through which the dumb and deaf people can interact. The dumb express their sensations and thoughts by means of the gesture language. Sign language identification is the method which every researcher would prefer.

Design issue and proposed Implementation of communication Aid for Deaf & Dumb people [9]: The author proposed the conversion of sign language into Indian sign language which is used to converse with the normal people where gestures of the hand is transformed into its corresponding text message .The core objective of the paper is to find an

algorithm to convert the simultaneous gestures into the real time operation.

Real time Detection and recognition of Indian and American Sign Language using Sift [10]: Hand gesture recognition for human computer interaction is the real time vision based used in this paper. The proposed paper could recognise up to 35 various hand gestures that are given by the Indian and the American Sign Language or ISL and ASL at the highest speed and with at most accuracy. To avoid false prediction the Red Green Blue to the Grey scale segmentation technique is used. In this Scale Invariant Feature Transform (SIFT) improvised version is promoted. MATLAB system is used for this model. GUI model has been implemented to have user friendly hand gesture recognition.

A Review on Feature Extraction 3 for Indian and American Sign Language [11]: Based on manual communication and body language this paper presents the recent research and development of the sign language .In this paper it undergo three stages pre-processing, feature extraction and classification. Neural network (NN), Support Vector Machine (SVM), Hidden Markov Models (HMM), Scale Invariant Feature Transform (SIFT) are the methods used by the classifications.

SignPro-An Application Suite for deaf and dumb [12]: The key feature in this paper is the real time gesture to text conversion. Deaf and Dumb people can communicate with the rest of the world using sign language is the main presentation of the paper. The processing stages include: Gesture extraction, gesture matching and conversion to speech. Gesture extraction has to undergo various stages in the image processing like the histogram matching, bounding box computation, skin colour segmentation and region growing. Techniques applicable for Gesture matching include feature point matching and correlation based matching. The other features include in the application are the voicing out of text and text to gesture conversion.

Offline Signature Verification Using Surf Feature Extraction and Neural Network Approach [13]: Offline signature recognition and verification using neural network is proposed in this paper, where the signature is caught and offered to the user in an image format.

Recognizing Hand Gesture using Wrist Shapes [14]: Virtual button system is used for the sign representation. It uses the shape of the wrist. Even a pinch of action could be noted. Using this motion is a favourable because to identify the picking, moving and releasing activity in natural way. Small sized IR optic sensor for the pattern of finger tendons is used. It specifies the moving ways of the finger. It also measures the applied force for the picking operation which is not possible by the vision approach. Virtual button implementation in possible by using the small sized IR sensor is the final report produced. It can also recognise the other hand motion like shaking and bending.

Measurement of flow using bend sensor [15]: This paper provides an innovative design and accurate approach to the measurement of flow rate for moderate flow application. Linear bond between duration of flow and the variation in resistance of the bend sensor is deduced in this setup. Installation and calibration of sensor is easy. It consists of one moving end with a fixed beam cantilever which would provide a digital output. The open end of

the sensor are analysed using ANSYS finite element analysis software provides the displacement value.

III. PROPOSED SYSTEM

In our proposed method ATMEL controller is used as the core controller. Flux sensor is for the identification of the hand movements and the data are accessed through the ATMEL board. LCD to display the message content which is the output from controller board. GSM module is used for the Transfer of message during the emergency duration. IR sensor is also used for the control of the room objects.

BLOCK DIAGRAM

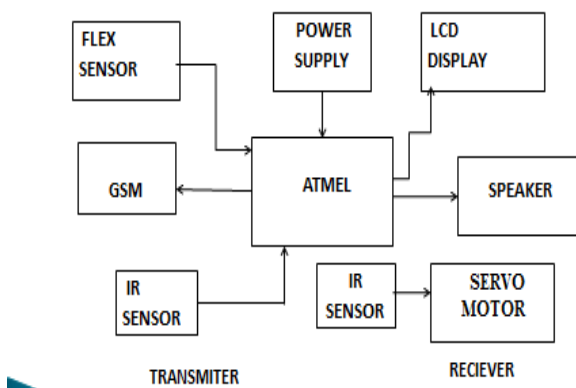

A) SENSORS

Sensor is an electronic utility which is used to detect some source resources from the physical environment. Environment is built by natural properties like water, natural light - sun, moisture contents which are available in greater phenomenon. Type of inputs present in the environment like the pressure, motion and moisture used to spot the variations and are displayed in digital method. The working of a sensor is normally considered to be equivalent the variable resistor. The digital signal is considered as the output and is send to the transreceiver for further process.

a) Flex sensor

Sensors are available in different types which are used to identify or detect different circumstances and objects. The sensor used for this analysis is FLEX SENSOR. This is different from other sensors which is flexible in type and could bend in any angle and directions. It detects the motion of the finger and produces the variations in the form of values. The variations produced from the bends of the finger are same as the detection of resistance value produced from any of the circuit. The sensor is fitted to the gloves accordance with the finger and the bend made by the finger is noted. There are two different ranges in the sensor as 2.2 and 4.4. The difference in them is the accuracy and the cost price. The performance of the 4.4 sensor is much better than the 2.2 sensor. The cost price of the sensor is the major amount for the project. Due to the high cost price the below average people don't even have an attempt to think about such a mean through which they could communicate. If the cost is reduced the value of the kit

becomes much cheaper and it is useful for the normal people to use it in a regular purpose.

To reduce the cost price of the sensors in the project, the sensor is made with easy available materials - which consist of cardboard sheet, aluminium foil sheet, white paper with graphite coating and copper wires. It has three layers; Cardboard- main purpose is for the stiffness of the sensor and gives strength to withstand for longer period. Aluminium foil-responsible for reflection loss and act as barrier for radiation. White sheet is scribbled with pencil- which acts as electrical supply. Black pencil has graphite components which tend to provide the necessary supply. One sensor is made by attaching these sensors in a layer. In between the strip we have to place two copper wires in which one is positive and the other one is negative that provide the resistance value which could be measured by using a multi-metre.

b) Infrared sensors

Infrared sensors sense the electrical object in vicinity. The sensor has peculiar quality to find the emitting heat of an object and also a motion is detected. It may be active type or passive type of sensors. The infrared output for passive sensor is the stoppages and its functions are to identify a heat that discharges by an obstacle. The quantum and thermal is a variety of passive infrared sensor. The thermal sensor source needs a very high temperature and there are some classification for thermal infrared sensor such as thermocouples, pyro electric and bolometers. Quantum infrared sensor is more gain to perceive infrared power, when compare to thermal infrared sensor. The quantum infrared sensors are rapid access of IR radiation. The nature of the wavelength in photosensitivity quantum sensors are dependent, the variety of quantum sensors were intrinsic model and extrinsic model, In intrinsic model they are categorized on the basis of cells as photoconductive model of cells and photovoltaic type of cells. Active infrared sensors are capable of self-illuminating. This type of sensor has ability to find instantly the range and velocity of the obstacles. An IR sensor has two portions one is IR transmitter another one is IR receiver. The transmitter part of sensor emits the infrared radiation. Its functions are equivalent to light emitting diode, which operates in a dc current in range of 3v and led utilization are 20mA. IR receiver will receive the emitted energy of a transmitter, it's performs are same as photodiode and phototransistor, this will diagnose infrared radiation from the transistor. The receiver values change depending upon the wavelength produced. The wavelength should be same as the receiver and transmitter signals, sometimes the wavelength are different to each other and do not provide any operation in the infrared sensors.

B) GSM MODULE

GSM belong to the generation of second and it works on systematically applying *Time Division Multiple Access* (TDMA). GSM is the most common mobile standard used worldwide. Modules are used to connect people through mobile handset. Operation of this module is at very low frequency and it uses many number of carrier frequency to transmit data. Variation between the frequencies is 900MHz-1800MHz. The MMS and the GSM system became operational. It works with the Time Division Multiplexing Access spectrum. In this project GSM purpose is to transfer the analog value that is obtained from the sensor. It transfers the values and the result is given in a digital way. The main purpose of the

module is to transfer message for the people who is distinct from the location. This system is useful during the emergency period to intimate the critical situation of the patient.

C) SOUND RECORDER:

Recorder records the acoustic waves of human voice. It has the special capacity to give voice information, the outcomes produced is similar to human voice. The purpose of the system is to introduce the voice more audible to listener, which doesn't make any confusion and they will be clear about the recording signal. It follows the storing technology of non-volatile in which flash memory stores the information, and doesn't need any battery backup. This seems to be a single chip, the recorder IC consist of two modes they are serial mode and parallel mode. The 256 section of sounds can be recorded at a stretch in a serial modes but in parallel mode the sounds can be chronicled as 2, 4, 8 sections. Audio signals of a player require 4-8 kHz samples per seconds; it is a 28 pin dual in package and the supply which is given to recorder are dc. The range of voltages is between 4.2v to 6.5v. In inactive mode the player consumes supply of 1micro amps. The recorder will retained current information of the sound wave even when the system is not contact to the power supply. In this module range of about 8 - 16 ohms speakers are used. The player can also be controlled by digital systems like microcontroller and computers. The voice recording and playback players are easy to hear the messages when compare to displays it is awkward to see in longer distance so recordings are more useful to the society. The application of recorder are speaking about the time which we set to a clock we will hear sharply when alarm rings, the voice are recorded in the toys which acts as game for kids. The advantage of the system is high quality in sounds, power consumption is low, and cost of the system is low and high in performance.

D) SERVO MOTOR

Servo motor is an electrical motor, which is used to move or rotate the object for some distance. It is just like a normal motor but the process is different. Servo motor operates on the process of servo mechanism. The function of a mechanism includes three parts they are controlled device, output sensors and feedback system. Closed loop are used in positive feedback system, it will control a movement and position of the shaft. It uses a two method of power supply such as DC and AC power supply. When the motor runs in a DC power it is said to be DC servo motor, sometimes the motor runs in AC power then we can take it as AC servo motor. Servo motor is fabricated with a potentiometer, gear parts, controlling circuits. High force acts as an object because of this pressure the object will rotate, at that time torque of the servo motor are increased thereby decreasing the range of an rpm. There are different kind of modulation technique, the servo motor are broadly used in pulse width modulation. The speed of a motor can be differed by the variable resistor. Objects can rotate from 0 to 180 degree, but it can still rotate up to 210 degree based on the manufacturing. Pulse of 1ms width make servo to rotate for 0 degree, 1.5ms can rotate up to 90 degree and 2ms pulse can rotate up to 180 degree. DC supply of 5v is required to run the servo motor. But the amount of consumption should be noted if two servo motors are used then proper shield should be maintained.

E) LCD DISPLAY

LCD display was seen in the today's electronics world. Liquid crystal display is a way to provide information electronically, it displays the character and numerical

values on the LCD display. These types of display are used in calculators, mobile phones, television and wash machines. It is alike to the character and numerical information that are visible to the human's eye. With the help of this system the information could be visible for some distance. The 16x2 display model are the basic model which shows the 16 column in the 2 rows. The 5x7 or 5x8 was the size of each character were seen in the system those arrangements are in the forms of pixel matrix. LCD's are used for numbered and alphabetical characters in dot matrix format and seven segment display. Electric field substance consists of liquid which is in transparent state. The disruption of the region takes place which initialise to the polarisation of the liquid. The advantage of using the LCD is- it requires low power consumption and LCD require small amount of voltage. They are economical. Dynamic scattering types of LCD are used for projects normally. Its display consists of two scattering glass type with the coating of thin oxide and transparent electrode. In dynamic scattering type LCD's consumes the power of 25 μ A. The peak-peak voltage of the display is 50 Hz.

IMPLEMENTATION

The movement of the fingers is detected by the Flux sensor. The working of the Flux sensor is similar to the potentiometer operation. The negative pin is provided with an analog supply from the ATMEL board followed by a resistance to avoid the flow in a stable manner and the ground connection. The positive pin is given about a minimum amount of supply from the board. Transformer is used to provide the supply. Two Transformers are used in which- the Atmel board is provided with a supply of 12V, the GSM with a 5v of supply and the IR sensor with 5V of supply. Sensor detection is done by the folding of the finger. Each finger has its own variation and value. When the particular finger has a movement it is analysed and next process takes place. When the fingers are in rest movement no value is read and the circuit is in stable system. The action of the finger is converted into the digital form. LCD display is to reveal the movement in the text form. This is useful for the people to read the content and help the patient. GSM module is utilized to facilitate the patient in the crisis period of time. The message indicated by the patient is transferred to the mobile number that is provided. This is useful to attend the patient the needs even at the peak time. The message display in the mobile may also be helpful when the patient is in unconscious state or in case of heart attack they could be attended immediately. Speaker is also provided along with the controller. This speaker converts it voice according to the gesture produced from the hand. The frequency range and the memory capacity of the speaker should be high in order to store the gesture provided by the fingers. as the movement is done the content is first displayed and the message is send to the phone and the content is spoken with the high frequency range with the help of speaker. Speaker is helpful for the people in the few distance could hear and help them. IR sensor is used in the project as an additional purpose. This is helpful in controlling the objects in the surrounding places. In the paper a Servo Motor is fixed which rotates when there is an obstacle in the IR sensor. Motor rotates to a particular angle and then stops at the same position when released.

FLOW CHART:

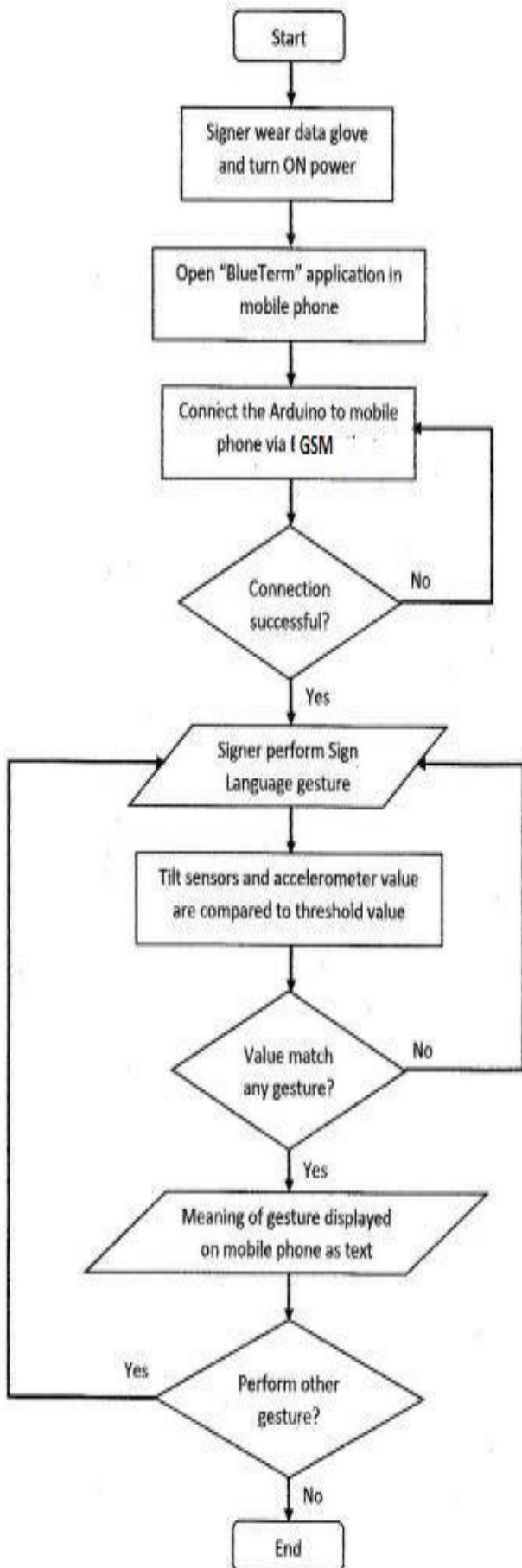

III. RESULT

By the action of finger the output is displayed on the LCD, SPEAKER and MESSAGE .The result consists of a) Message in the LCD b) Message transferred through GSM in phone

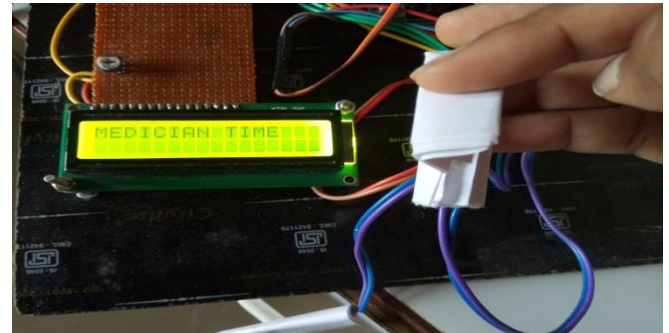

a) Lcd displays the action of finger



- b) Message that is delivered to the phone using GSM module

IV. CONCLUSION

The outcome of the paper conducted shows that the structure effectively detects the gestures and the output is simultaneously produced. The curves and the twist of the tilt sensor help in detecting the words/gesture. There are 4 gestures tested in the paper for each fingers action and in the future works depending on the angle more recognition of signs could be done. Depending on the number of sign movements in a finger the series of the sensor should be varied accordingly. This assists the aphasia patient as well as the deaf and dumb people. Microcontroller platform is used for the constructive purpose of the voice identification system. Which provide a high stability and durability. Cost is reduced to a nominal way and useful for the normal people affordable rate.

REFERENCES:

- [1] Sakshi Goyal, Ishita Sharma, Shanu Sharma “Sign language Recognition system for deaf and dumb people”, International Journal of Engineering Research & Technology (IJERT), 2013.
- [2] Suharjit , Ricky Anderson, Fanny Wiryana, Meita Chandra Ariesta, Gede Putra Kusuma “Sign Language Recognition Application Systems for Deaf-mute People, 2017, <https://www.sciencedirect.com/science/article/pii/S187750917320720>.
- [3] Sunitha K. A, Anitha Saraswathi.P, Aarthi.M, Jayapriya. K, Lingam Sunny, “Deaf Mute Communication Interpreter- A Review”, International Journal of Applied Engineering Research, Volume 11, pp 290-296 , 2016.
- [4] Mathavan Suresh Anand, Nagarajan Mohan Kumar, Angappan Kumaresan, “ An Efficient Framework for Indian Sign Language Recognition Using Wavelet Transform” Circuits and Systems, Volume 7, pp 1874-1883, 2016.
- [5] Mandeep Kaur Ahuja, Amardeep Singh, “Hand Gesture Recognition Using PCA”, International Journal of Computer Science Engineering and Technology (IJCSET), Volume 5, Issue 7, pp. 267-27, July 2015.
- [6] Sagar P. More, Prof. Abdul Sattar, “Hand gesture recognition system for dumb people”,
- [7] International Journal of Science and Research (IJSR)
- [8] Chandandeep Kaur, Nivit Gill, “An Automated System for Indian Sign Language Recognition”, International Journal of Advanced Research in Computer Science and Software Engineering.
- [9] Pratibha Pandey, Vinay Jain, “Hand Gesture Recognition for Sign Language Recognition: A Review”, International Journal of Science, Engineering and Technology Research (IJSETR), Volume 4, Issue 3, March 2015 .
- [10] Nakul Nagpal, Dr. Arun Mitra., Dr. Pankaj Agrawal, “Design Issue and Proposed Implementation of Communication Aid for Deaf & Dumb People”, International Journal on Recent and Innovation Trends in Computing and Communication, Volume: 3 Issue: 5, pp-147 –149.
- [11] Neelam K. Gilorkar, Manisha M. Ingle, “Real Time Detection And Recognition Of Indian And American Sign Language Using Sift”, International Journal of Electronics and Communication Engineering & Technology (IJECET), Volume 5, Issue 5, pp. 11-18 , May 2014
- [12] Neelam K. Gilorkar, Manisha M. Ingle, “A Review on Feature Extraction for Indian and American Sign Language”, International Journal of Computer Science and Information Technologies, Volume 5 (1) ,pp- 314-318, 2014.
- [13] Ashish Sethi, Hemanth , Kuldeep Kumar, Bhaskara Rao , Krishnan R, “Sign Pro- An Application Suite for Deaf and Dumb”, IJCSET , Volume 2, Issue 5, pp-1203-1206, May 2012.
- [14] J. Lim, D. Lee, & B. Kim, “Recognizing Hand Gesture using Wrist Shapes”, 2010 Digest of Technical Papers of the International Conference on Consumer Electronics (ICCE), Las Vegas, 2010, pp 197-198
- [15] C.R. Srinivasan, S. Sen, A. Kumar, C. Saibabu, “Measurement of Flow Using Bend Sensor”, 2014 International Conference on Advances in Energy Conversion Technologies (ICAECT), 2014, pp 27-30