

# Flextural behaviour of steel-concrete-steel composite beam with internal curing agent

G.ANANTHA BHARATHI  
PG Student of Structural Engineering  
Mepco Schlenk Engineering College  
Sivakasi, Tamilnadu, India  
Email: bharathi11893@gmail.com

R.THEENATHAYALAN  
Assistant Professor, Civil Department  
Mepco Schlenk Engineering College  
Sivakasi, Tamilnadu, India  
Email: theena@mepcoeng.ac.in

**Abstract**— nowadays scarcity of water is of the problems faced in all over the world. For construction we are using large amount of water for curing itself, to reduce the usage of water we can use self curing concrete for the construction purpose. To minimize the size of the structure without reducing the load carrying capacity we can go for the composite member. In this paper steel-concrete-steel composite members are analyzed, in which super absorbent polymer (SAP) is used as an internal curing agent. SAP is a material can absorb the water of about 500 times in its own weight and converts it into a gel, this property of SAP is utilized for internal curing in concrete. SAP supplies water to the concrete for hydration reaction and called as three dimensional curing. Sandwich beam is a place where we cannot able to cure the concrete so we are going for internal curing. In this study SAP is added to concrete by the weight of cement to the optimum level so as to get the maximum strength without any external curing. Bi-steel member is used so as we can obtain the maximum strength by welding the strut on the either side of the panel in which self curing concrete is used as a filler. The stress, strain behavior and load, deflection for the beam is analyzed using ANSYS.

**Key words:** flexural behavior, composite beam, sandwich, self curing, super absorbent polymer, steel-concrete-steel, bi-steel.

## I. INTRODUCTION

Concrete is one of the most widely used construction material in the world wide because of its ability to get cast on any form or shape. Concrete is a very durable material needs no maintenance. To make the concrete strong and durable we need to cure the concrete, curing is done using the conventional water that is used for the mix. It is found that one third of water used for the construction purpose is spent for curing purpose.

Nowadays there is a scarcity of water all over the world, to minimize the water consumption for the concrete construction self-curing concrete is developed. Composite construction is also a one of the emerging techniques that reduces the size of the member without reducing its load carrying capacity. Sandwich construction is used in the field of production of precast member, in which concrete is sandwiched between steel plates. Sandwich member is the place where we cannot able to cure the concrete in between the steel plates, so self curing concrete is used for sandwich construction. Concrete with insufficient curing may lead to lots of damage to the structure, shrinkage and formation of early age cracking are some of the damages occurred in concrete due to the insufficient curing.

### A. Super absorbent polymer (SAP):

Super absorbent polymer (sodium polyacrylate) is a powder like material that can absorb water about 500 times of its own weight. It converts the absorbed water into gel, and that can be used for curing in concrete later.



Fig. 1. Super absorbent polymer.

### B. Sandwich beam:

Sandwich beam is a member in which two steel plates are connected with a strut steel member. Bi-steel member is used as an sandwich specimen, two steel plates are welded apart with an steel rods. For sandwich beam 6mm thick steel plate and 8mm dia. Steel bars are used.

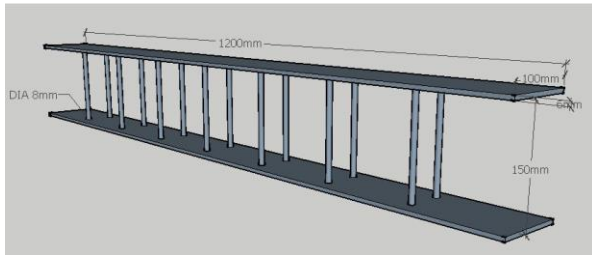

Fig.2. longitudinal section of a sandwich beam

The cross section of a sandwich member is 100mm wide and 150mm deep. Spacing between the struts in longitudinal direction is 150mm and spacing in transverse direction is 50mm.

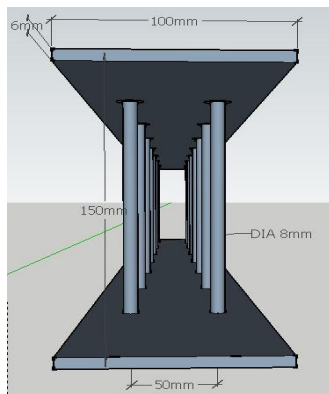

Fig.3. cross section of a sandwich beam

## II. SCOPE & SIGNIFICANCE

Self curing concrete is made using super absorbent polymer (SAP) so the cost of construction is reduced by minimizing the amount of water used for construction. Autogenous shrinkage is reduced by using SAP as an internal curing agent, it acts as a reservoir for the concrete curing it supplies water to the concrete for hydration reaction from inside. Internal curing agent is also used to minimize the early age cracking by supplying water regularly for hydration of concrete.

Sandwich members are used for the construction of precast structures, by which the size of the structure is reduced without decreasing its strength. In sandwich member we cannot cure the concrete, which is between two steel plates. By using self curing concrete instead of conventional concrete the strength of the member remains unchanged.

## III. SPECIMEN TYPES

Two types of sandwich specimen are analyzed for comparing the flexural behavior

B1-sandwich beam with conventional M20 grade concrete.

B2-sandwich beam with concrete having SAP as an internal curing agent.

## IV. EXPERIMENTAL WORK

### A. Optimum percentage of SAP and Young's modulus:

To find the optimum percentage of SAP added concrete cubes are cast and tested after 28 days without any external curing.

Young's modulus for conventional M20 grade concrete and young's modulus for M20 grade concrete with SAP as an internal curing agent are found. The results show that the concrete with 2% SAP as an internal curing agent has maximum strength when compared to other proportions. 2% of SAP by the weight of cement added is fixed as an optimum percentage for concrete, can be used as a filler for the sandwich specimen.

Concrete type	Young's modulus N/mm <sup>2</sup>
Conventional M20	23767
M20 with 2% SAP	23452

Table.1. young's modulus

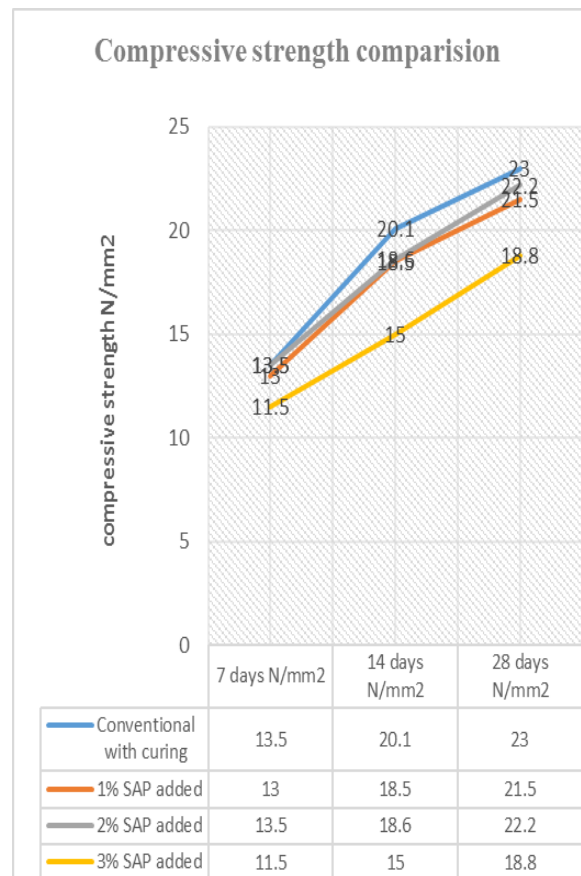

Chart.1. compressive strength comparison

V. ANALYTICAL WORK

A. Element used:

A. Concrete: (SOLID 65)

The Solid65 element having eight nodes with three degree of freedom at each node is used for modeling the concrete. This element is having capability of plastic deformation, cracking in three orthogonal directions, and crushing.

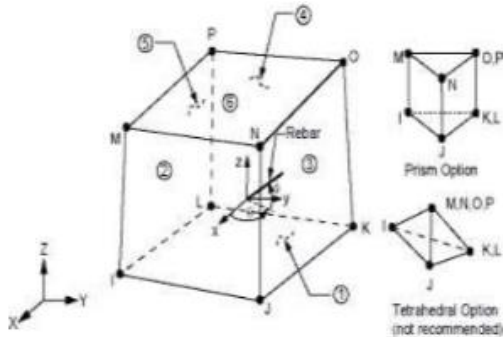

Fig.4 Element Solid 65

B. Steel Strut: (LINK 180)

A Link180 element is used to model steel strut. This element is a 3D spar element and it has two nodes with three degrees of freedom – translations in the nodal x, y, and z directions.

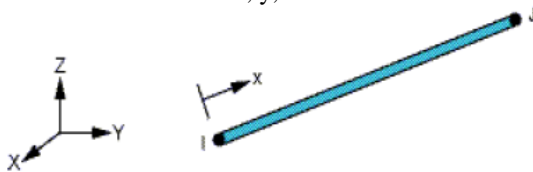

Fig.5 Element Link 180

C. Steel plate: (SHELL 41)

A Shell 41 is used to model the Steel plate. It has both bending and membrane capabilities. Shell 41 is a 3D element having membrane stiffness but no bending stiffness. It is used for shell structures where bending of the elements is of secondary importance. The element has three degrees of freedom at each node: translations in the nodal x, y, and z directions. It is shown in fig.6

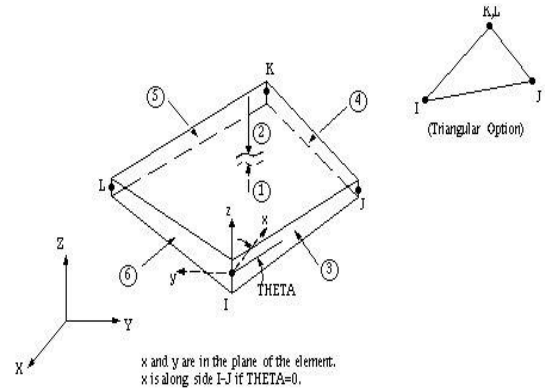

Fig.6 Element shell 41

VI. MODELLING OF SPECIMEN

A. Element properties:

The elemental properties of the material are given in the preprocessor stage of the ANSYS software.

A. Element Types:

The ANSYS contains more than 100 different element types for a material to be considered. Each element type has a unique characteristic features and a prefix that identifies the element category.

Table 2 Element type

Material	ANSYS Element
Concrete	SOLID 65
Steel strut	LINK 180
Steel plate	SHELL 41

B. Real Constants:

Real constants are the constant values which are required for the element matrix calculation, as it is independent from nodal locations and properties. Typical real constants include area, thickness, inner and outer diameter, etc. Every element type have their basic real constants.

A. Sandwich beam with conventional M20:

Table 3 Real constant for control beam

ANSYS Element	Real constant
LINK 180	Set 1
SOLID 65	Set 2
SHELL 41	Set 3

Set 1: Area 8 mm bar 50 mm<sup>2</sup>.  
 Set 2: Solid 65 all values given zero.  
 Set 3: Thickness 6mm.

B. Sandwich beam with 2% SAP,M20:

Table 4 Real constant for control beam

ANSYS Element	Real constant
LINK 180	Set 1
SOLID 65	Set 2
SHELL 41	Set 3

Set 1: Area 8 mm bar 50 mm<sup>2</sup>.  
 Set 2: Solid 65 all values given zero.  
 Set 3: Thickness 6mm.

C. Material Properties:

Various material properties are used for each element type. Typical material properties include Young's modulus (modulus of elasticity), Poisson ratio, etc.

Table 5 Material Properties for Sandwich with M20

Material	Young's modulus (N/mm <sup>2</sup> )	Poisson ratio
Concrete (M20)	23767	0.2
Steel strut (Fe 415)	2x10 <sup>5</sup>	0.3
Steel plate	2x10 <sup>5</sup>	0.3

Table 6 Material Properties for Sandwich with M20,2% SAP

Material	Young's modulus (N/mm <sup>2</sup> )	Poisson ratio
Concrete (M20)	23452	0.2
Steel strut (Fe 415)	2x10 <sup>5</sup>	0.3
Steel plate	2x10 <sup>5</sup>	0.3

B. Modeling of specimen:

A. Concrete modeling:

Sandwich beams are taken for analysis are simply supported beams with span of 1.2 m and cross section of 100mm x 150mm.

The SOLID65-3D concrete element simulates tension and compression properties in concrete. The required properties include elastic modulus, and Poisson's ratio, which are indicated in Table 5.

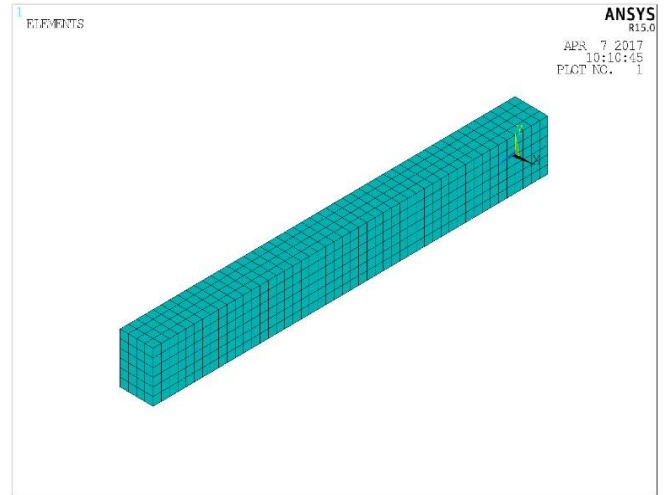

Fig.7 Modeling of concrete beam element

B. Steel plate Modeling:

Steel plate is model by SHELL 41 element. Key points are created at required co-ordinates (x, y and z axes) and these points are connected by lines. Area inside these lines are converted into single area. Mesh these area by 25x25mm by giving SHELL 41 properties. The image of upper and bottom steel plates having thickness of 6mm is shown in the fig 8.

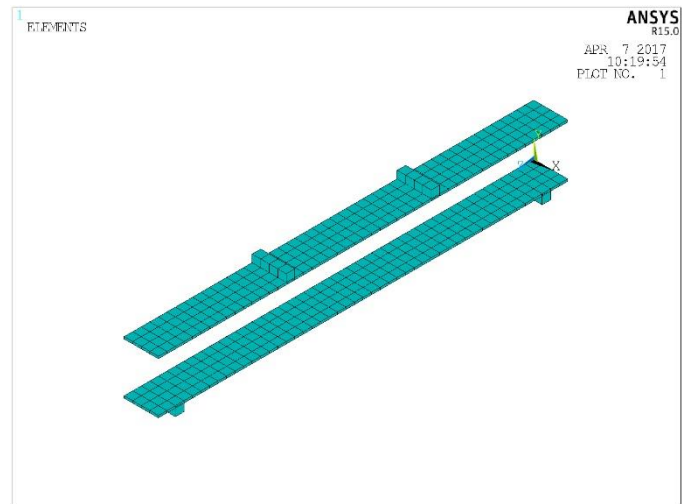

Fig.8 Modeling of steel plates

C. Steel strut Modeling:

Steel strut model is created by using nodal points at required places with the properties of LINK 180 elements. The simulated steel strut elements are shown in the fig. 9.



Fig.9 Modeling of steel struts

The steel strut is fixed between the steel plates and make an sandwich specimen. The simulated sandwich specimen with steel strut is shown in the fig.10

Maximum deflection for the two sandwich beams are shown in the following figures. The maximum deflection for the beam having conventional M20 grade concrete is 5.48mm and for beam having 2% SAP as an internal curing agent is 5.57mm for a pressure of 100 KN/mm<sup>2</sup>.

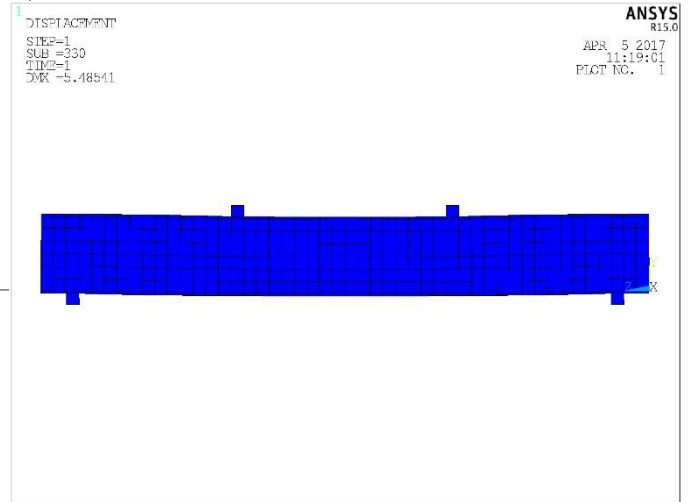

Fig.10 Maximum deflection of conventional M20 beam

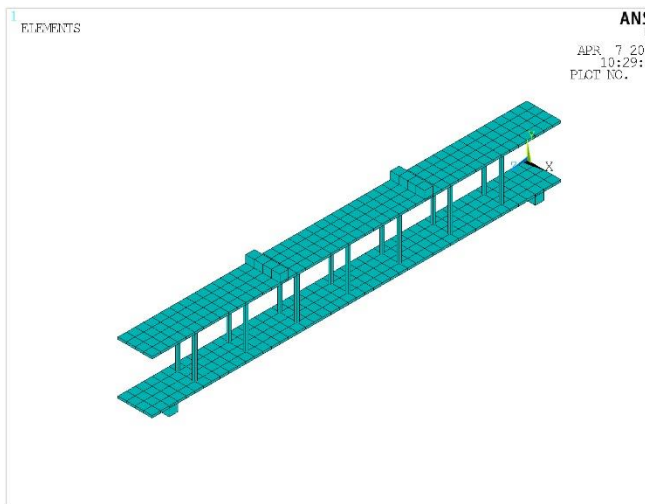

Fig.9 Modeling of sandwich specimen

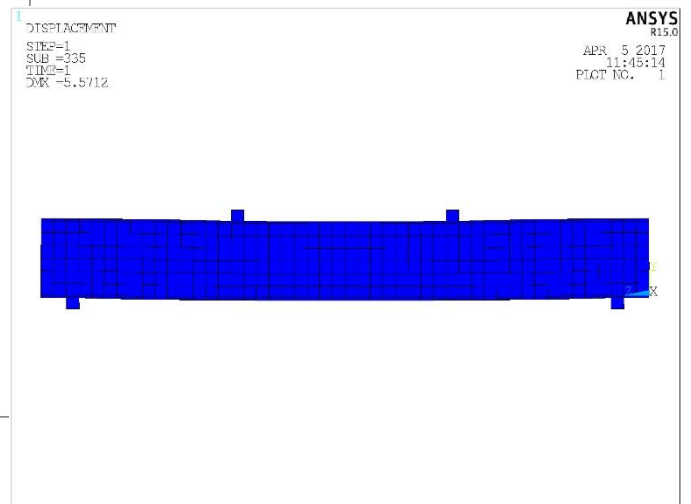

Fig.11 Maximum deflection of beam with 2%SAP as an internal curing agent

C. Nonlinear analysis:

In this analysis load is applied on the basis of load steps. Newton-Raphson equilibrium iteration is used for analyzing using ANSYS. Displacement is given in UY and UZ direction at the bottom of the beam specimen at a distance of 50mm from its edge. Load is applied as a pressure of 100 KN/mm<sup>2</sup> at an element which is at one third distance from both ends of the beam specimen.

VII. RESULT AND DISCUSSION

After analyzing, the results are compared between the sandwich beam with conventional M20 concrete and the sandwich beam having concrete with 2%SAP as an internal curing agent.

A. Max deflection:

B. Stress distribution in sandwich specimen:

Von misses stress diagram for both conventional and 2%SAP sandwich beam specimen are shown in the following figures. For conventional specimen maximum stress is 705.901 MPa and for the specimen having 2%SAP as an internal curing agent is 708.084 MPa.

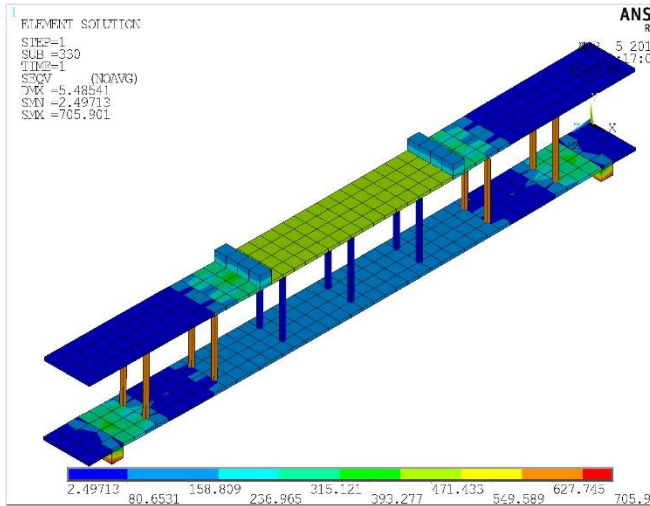

Fig.12 Von misses stress diagram for conventional M20 beam

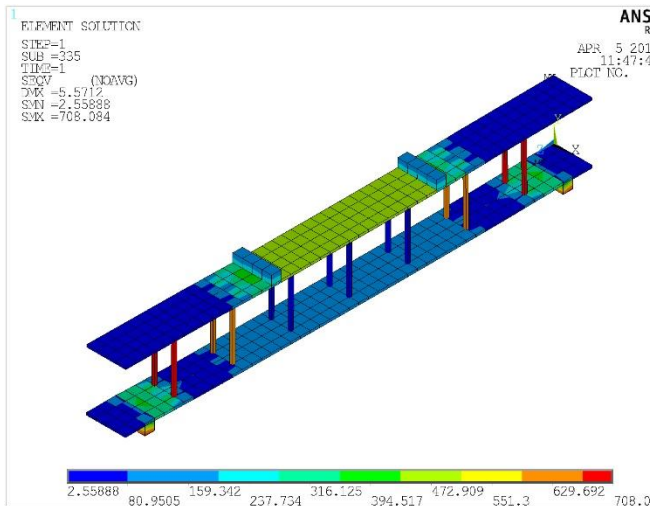
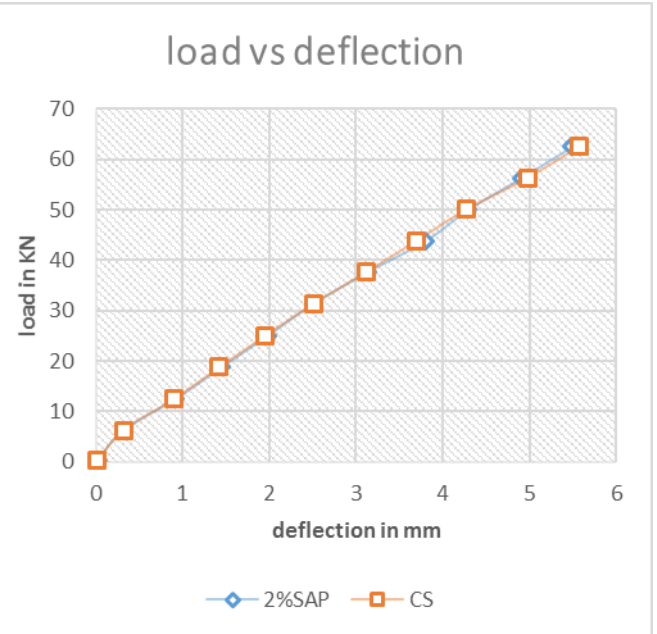

Fig.13 Von misses stress diagram for M20 beam with 2% SAP

From the load vs deflection graph found that load carrying capacity for the sandwich beam with 2%SAP as internal curing agent is nearly same as that of sandwich beam with conventional M20 grade concrete.

### VIII. CONCLUSION

It is found that 2% by the weight of cement added to the concrete is the maximum percentage of SAP that we can add to the mix for the maximum strength, without any external curing.

This comparative study between sandwich beam having conventional and self curing concrete is done by using ANSYS v15.0 software.

This comparative study shows that there minimum increase of deflection for 2%SAP sandwich beam for the same amount of load but the difference is minimal. So we can adopt self curing instead of conventional concrete for minimizing the usage of water for construction.

### C. Load vs deflection curve:

Load vs mid span deflection curve for the sandwich beams are shown in following chart.

### REFERENCES

1. Dejian Shen, Xudong Wanga, Dabao Cheng, Jinyang Zhang, Guoqing Jiang.” Effect of internal curing with super absorbent polymers on autogenous shrinkage of concrete at early age “Construction and Building Materials 106 (2016) 512–522
2. D. Cusson \*, Z. Lounis, L. Daigle ”Benefits of internal curing on service life and life-cycle cost of high-performance concrete bridge decks – A case study” Cement & Concrete Composites 32 (2010) 339–350
3. J. Justs, M.Wyrzykowski,D. Bajareb, P. Lura “Internal curing by superabsorbent polymers in ultra-high performance concrete” Cement and Concrete Research 76 (2015) 82–90

4. Ravindra D. Warkhade, Mahesh S. Varpe, Vikas S.Dhangar, Varsha S.Dalvi, Prof.S.G.Upadhyay “ use of sap in concrete “ international journal of advance research and engineering vol.n.o.5 , march 2016.
5. Ranjith S, Annadurai R, Gunasekaran K, Lakshmi T.S “Study On Flexural Behavior of Steel Coconut Shell Concrete - Steel Sandwich Beam using Quarry Dust ” International Journal for Innovative Research in Science & Technology| Volume 1 | Issue 11 | April 2015.
6. B. McKinley, L.F. Boswell “Behaviour of double skin composite construction “Journal of Constructional Steel Research 58 (2002)
7. Dr. Amjad Hameed Abdul-Razaq, Civil Eng. Dept.College of Engineering, Kufa University, Al-Najaf, Iraq “Experimental and analytical study of the steel-concrete-steel beam under flexural behavior “