

Design and Analysis Characterization of Glass Fiber Reinforcement with Aluminium Laminates

*Note: Sub-titles are not captured in Xplore and should not be used

Muthu Pandi T
M.E (CAD/CAM)

Dept of Mechanical Engineering
Valliammai Engineering College,

SRM Nagar, Kattankulathur,
chennai-603203

Abstract—Fiber metal laminates are good candidates for advanced aerospace structural applications due to their high specific mechanical properties especially fatigue resistance. The most important factor in manufacturing of these laminates is the adhesive bonding between aluminum and FRP layers. In this study several glass-fiber reinforced aluminum laminates with different bonding adhesion were manufactured. Mechanical Tests like Tensile, Compression, Flexural and Double shear tests were carried out based on ASTM standard were then conducted to study the effects of interfacial adhesive bonding on impact behavior of these laminates. It was observed that the damage size is greater in laminates with poor interfacial adhesion compared to that of laminates with strong adhesion between aluminum and glass layers. It is observed that when the Glass Fiber Thickness Fraction (GFTF) is increased the tensile Strength , compression load , flexural load and shear load is increased. When the Glass Fiber Thickness Fraction (GFTF) increased 0.66 , 0.75 and 0.83. This is because Glass Fiber Reinforced Epoxy has more strength than Aluminium.

Keywords— Aluminium 6061 , Glass Fiber (Chopped Strand Mat) , Resin (EPOXY LY556) and Hardener (HY951)

I. INTRODUCTION

Basic requirements for the better performance efficiency of an aircraft are high strength, high stiffness and low weight. The conventional materials such as metals and alloys could satisfy these requirements only to a certain extent. This lead to the need for developing new materials that can whose properties were superior to conventional metals and alloys, were developed.

A composite is a structural material which consists of two or more constituents combined at a macroscopic level. The constituents of a composite material are a continuous phase called matrix and a discontinuous phase called reinforcement.

A composite material (also called a composition material or shortened to composite, which is the common name) is a material made from two or more constituent materials with significantly different physical or chemical properties that, when combined, produce a material with characteristics different from the individual components. The individual components remain separate and distinct within the finished

structure, differentiating composites from mixtures and solid solutions.

II. MATERIAL SELECTION:

- Aluminium 6061
- Glass Fiber GSM 400 (Chopped Strand Mat)
- Mixing of Resin and Hardener 10:1
- Resin : LY556
- Hardener : HY951

A. Aluminium 6061

6061 is a precipitation-hardened aluminium alloy, containing magnesium and silicon as its major alloying elements. It has good mechanical properties, exhibits good weldability, and is very commonly extruded (second in popularity only to 6063).It is one of the most common alloys of aluminium for general-purpose use. 6061 is a precipitation hardened aluminium alloy, containing magnesium and silicon as its major alloying elements. It has good mechanical properties, exhibits good weldability, and is very commonly extruded (second in popularity only to 6063).It is one of the most common alloys of aluminium for general-purpose use.It is commonly available in pre-tempered grades such as 6061-O (annealed), tempered grades such as 6061-T6 (solutionised and artificially aged) and 6061-T651 (solutionised, stress relieved stretched and artificially aged).

S.NO	ELEMENT	SYMBOL	WEIGHT(%)
1	Silicon	Si	0.4-0.8
2	Iron	Fe	0.7
3	Copper	Cu	0.15-0.4
4	Manganese	Mn	0.15
5	Magnesium	Mg	0.8-1.2
6	Chromium	Cr	0.04-0.35
7	Zinc	Zn	0.25
8	Titanium	Ti	0.15
9	Aluminium	Al	95.85-98.56

Identify applicable funding agency here. If none, delete this text box.

B. Glass Fiber (Chopped Strand Mat)

Chopped strand mat (or CSM) is widely used in mould making and the production of low cost GRP mouldings such as panels and small boat hulls. Short strands of glass are randomly scattered and bound to create a mat which can then be wetted out with resin. CSM offers comparatively poor performance compared with higher performing and more expensive reinforcements but it is useful for increasing the thickness and therefore stiffness of parts in a cost effective manner.

S.NO	CHEMICAL NAME	MOLECULAR FORMULA	OXIDE (%)
1	Silicon dioxide	SiO ₂	52-56
2	Aluminium oxide	Al ₂ O ₃	12-16
3	Boron trioxide	B ₂ O ₃	5-10
4	Calcium oxide	CaO	16-25
5	Magnesium oxide	MgO	0-5
6	Disodium + Potassium oxide	Na ₂ + K ₂ O	0-2
7	Titanium dioxide	TiO ₂	0-1.5
8	Iron (III) oxide	Fe ₂ O ₃	0-0.8
9	Fluorine	F	0.1

C. Epoxy Resin (LY 556)

Epoxy is either any of the basic components or the cured end products of epoxy resins, as well as a colloquial name for the epoxide functional group. Epoxy resins, also known as polyepoxides, are a class of reactive prepolymers and polymers which contain epoxide groups. Epoxy resins may be reacted (cross-linked) either with themselves through catalytic homo polymerisation, or with a wide range of co-reactants including Poly functional amines, acids (and acid anhydrides), phenols, alcohols and thiols (usually called mercaptans).

D. Hardener (HY 951)

It is the very fast curing properties in composite material. Hardener is also one of the main matrix in composite material. Without hardener, epoxy resin is no use. Same as without resin, hardener is useless. When these both combines will gives an fabricated laminate. The hardener will more strength to the laminate and it will strength the specimen. Without hardener, epoxy resin is no use. Same as without resin, hardener is useless. When these both combines will gives an fabricated laminate. The hardener will more strength to the laminate and it will strength the specimen.

III. LAYOUT ARRANGEMENT TO VARIOUS METAL THICKNESS FRACTION (MTF)

A. Sample 1

Al sheet 2 layers = 1mm

GF 3 layers = 5mm

Total thickness = 6mm

Al sheet each layer = 0.5mm

GF each layer = 5/3

= 1.66mm

Al = 2 layers

= 2×0.5

= 1mm

GF = 3 layers

= 3×1.66

= 4.98mm

MTF=5/6

= 0.83

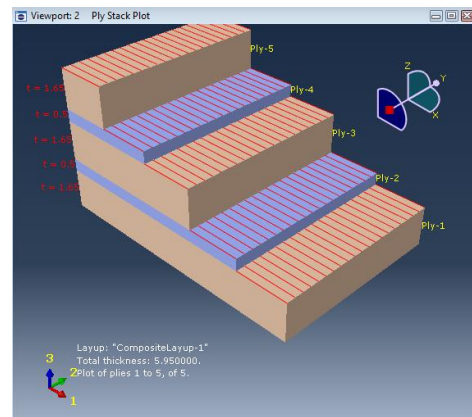

Fig 3.1 2 layer of Al sheet and 3 layer of Glass Fiber

B. Sample 2

Al sheet 3 layers = 1.5mm

GF 4 layers = 4.5mm

Total thickness = 6mm

Al sheet each layer = 0.5mm

GF each layer = 4.5/4

= 1.1mm

Al = 3 layers

= 3×0.5

= 1.5mm

GF = 4 layers

= 4×1.1

$$=4.4\text{mm}$$

$$\text{MTF}=4.5/6$$

$$=0.75$$

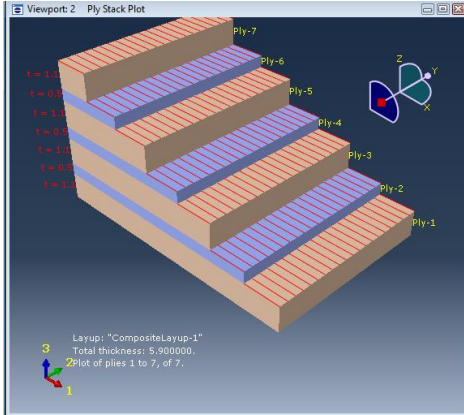

Fig 3.2 3 layer of Al sheet and 4 layer of Glass Fiber

C. Sample 3

Al sheet 4 layers = 2mm

GF 5 layers = 4mm

Total thickness = 6mm

Al sheet each layer = 0.5mm

GF each layer = 4/5

= 0.8mm

Al = 4 layers

= 4×0.5

= 2mm

GF = 5 layers

= 5×0.8

= 4mm

MTF=4/6

=0.66

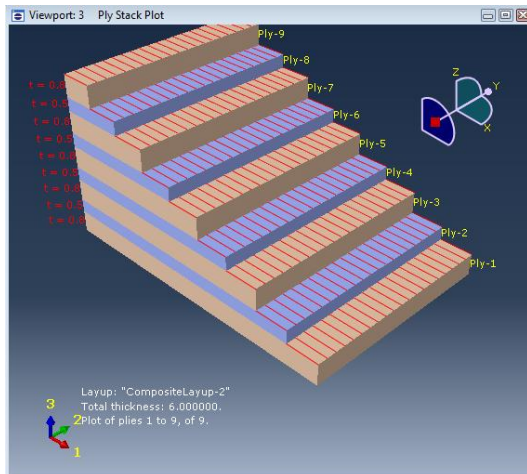

Fig 3.2 4 layer of Al sheet and 5 layer of Glass Fiber

IV. LAMINATE PREPARATION

Read the data sheet supplied with the product to determine the ratio of your particular epoxy. Although usually given on a volume basis (e.g. 5:2 parts resin to hardener respectively), some systems also give a weight ratio, which is nearly always different. For instance, a system of 5:2 mix ratio by volume may be 3:1 by weight.

METHOD : HAND LAY-UP METHOD

Even though the method has been replaced with automated techniques, the lay-up of pre impregnated material by hand is the oldest and most common fabrication method for advanced composite structures. Furthermore, the basic features of the method remain unchanged. Each step must follow in successive fashion in order to obtain a high-quality composite laminate after final processing. A description of these steps follows.

1. First of all, apply gel on the mold surface to avoid the sticking of polymer to the surface.
2. Thin plastic sheets are used at the top and bottom of the mold plate to get good surface finish of the product.
3. Reinforcement in the form of chopped strand mats are cut as per the mold size and placed at the surface of mold after perspex sheet.
4. Then thermosetting polymer (resin) in liquid form is mixed thoroughly in suitable proportion with a prescribed hardner (curing agent) and poured on to the surface of mat already placed in the mold.
5. The polymer is uniformly spread with the help of brush.
6. Second layer of mat is then placed on the polymer surface and a roller is moved with a mild pressure on the mat-polymer layer to remove any air trapped as well as the excess polymer present.
7. The process is repeated for each layer of polymer and mat, till the required layers are stacked.
8. After placing the plastic sheet, release gel is sprayed on the inner surface of the top mold plate which is then kept on the stacked layers and the pressure is applied.
9. After curing either at room temperature or at some specific temperature, mold is opened and the developed composite part is taken out and further processed.
10. The time of curing depends on type of polymer used for composite processing. For example, for epoxy based system, normal curing time at room temperature is 24-48 hours. This method is mainly suitable for thermosetting polymer based composites.
11. The schematic of hand lay-up is shown in figure.....

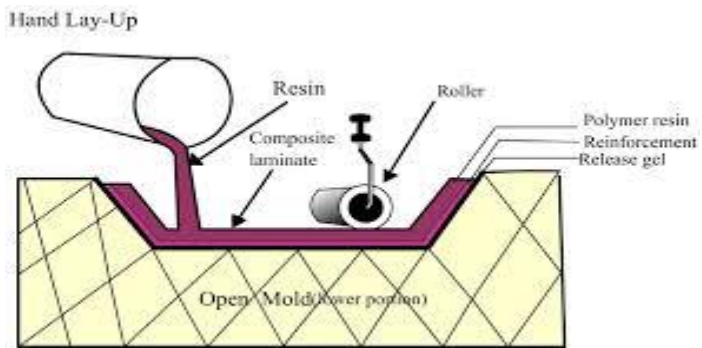
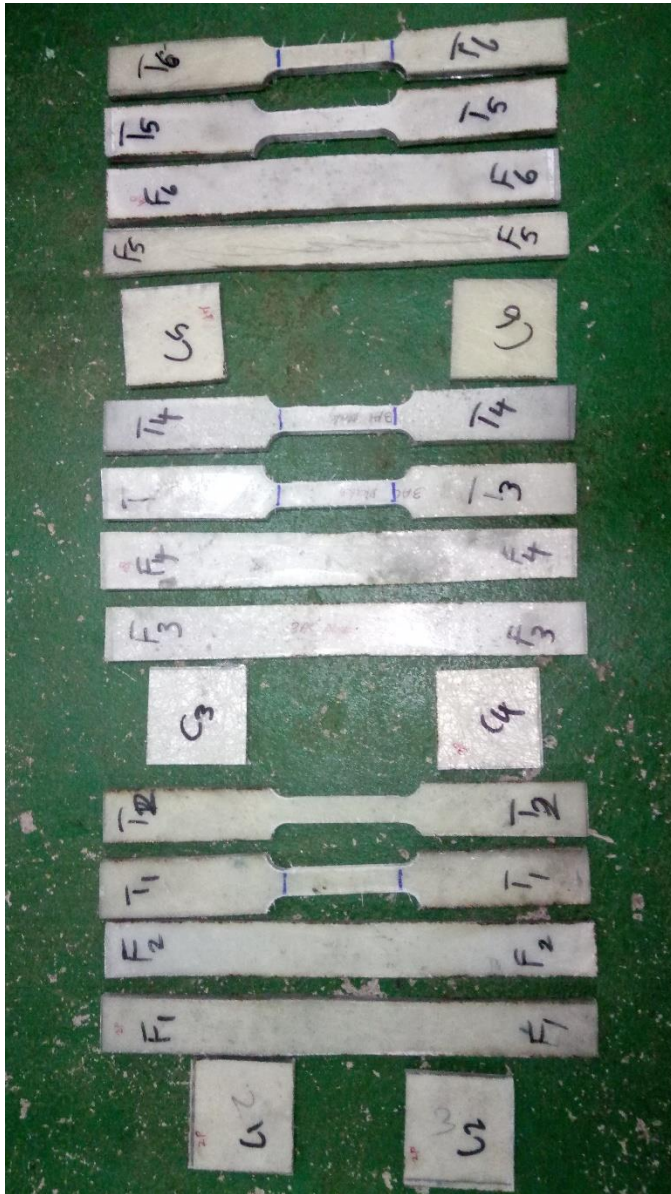

Fig 4.1 Hand Lay-up Method

A. Specimen



1. Tensile test:

Tensile strength is defined as a stress, which is measured as force per unit area.

The most common type of test used to measure the mechanical properties of a material is the tension test is widely used to provide a basic design information on the strength of materials.



S.NO	TEST	TYPE 1	TYPE 2	TYPE 3
1	Tensile load in KN	10.565	9.075	8.435
2	Tensile strength in MPa	109.95	97.04	82.035

Discussion:

It is observed that when the Glass Fiber Thickness Fraction (GFTF) is increased the tensile strength is increased. The tensile strength increased by 18.29. When the Glass Fiber Thickness Fraction (GFTF) increased by 13.30. When the Glass Fiber Thickness Fraction (GFTF) increased for 0.75 to 0.83. This is because glass Fiber Reinforced Epoxy has more tensile strength than Al.

2. Flexural test:

In this test a specimen with rectangular or flat cross section is placed on two parallel supporting pins. The loading force is applied in the middle by means loading pin.



S.NO	TEST	TYPE 1	TYPE 2	TYPE 3
1	Flexural load bending in mm	8.4	7.1	6.2

Discussion:

It is observed that when the Glass Fiber Thickness Fraction (GFTF) is increased the Flexural Load is increased. The Flexural Load increased by 14.69. When the Glass Fiber Thickness Fraction (GFTF) increased by 14.48. When the Glass Fiber Thickness Fraction (GFTF) increased for 0.75 to 0.83. This is because glass Fiber Reinforced Epoxy has more Flexural Load than Al.

3. Compression test:

Compression testing is a very common testing method that is used to establish the compressive force or crush resistance of a material and the ability of the material to recover after a specified compressive force is applied and even held over a defined period of time.



S.NO	TEST	TYPE 1	TYPE 2	TYPE 3
1	Compression load in KN	13.365	12.81	12.33

Discussion:

It is observed that when the Glass Fiber Thickness Fraction (GTF) is increased the Compression Test is increased. The Compression Load increased by 3. When the Glass Fiber Thickness Fraction (GTF) increased by 4.40. When the Glass Fiber Thickness Fraction (GTF) increased for 0.75 to 0.83. This is because glass Fiber Reinforced Epoxy has more Compression Load than Al.

4. Double shear test:

simultaneous shear across two usually parallel planes.

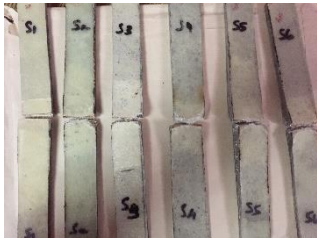

S.NO	TEST	TYPE 1	TYPE 2	TYPE 3
1	Double shear load in KN	7.935	7.65	5.485

Discussion:

It is observed that when the Glass Fiber Thickness Fraction (GTF) is increased the Double shear Load is increased. The Double shear Load increased by 39.47. When the Glass Fiber Thickness Fraction (GTF) increased by 3.725. When the Glass Fiber Thickness Fraction (GTF) increased for 0.75 to 0.83. This is because glass Fiber Reinforced Epoxy has more Double shear Load than Al.

Testing Results:

S.NO	TEST	TYPE 1	TYPE 2	TYPE 3
1	Glass Fiber Thickness Fraction (GTF)	0.83	0.75	0.66
2	Tensile test in KN	10.565	9.075	8.435
3	Tensile strength in MPa	109.95	97.04	82.035
4	Flexural load in KN	8.4	7.1	6.2
5	Double shear load in KN	7.935	7.65	5.485
6	Compression load in KN	13.365	12.81	12.33

V. ANALYTICAL PROCESS

1. Tensile test

Sample 1:

Step 1

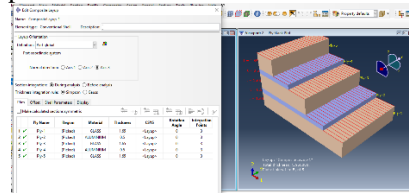

Step 2

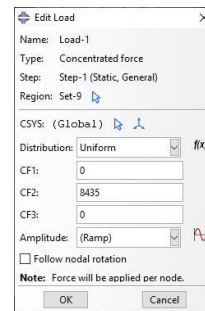

Step 3

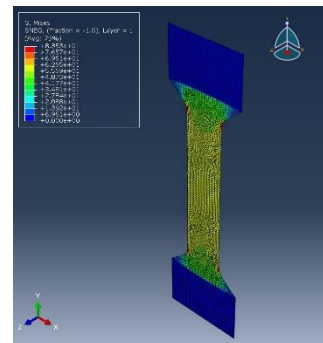

Sample 2:
Step 1

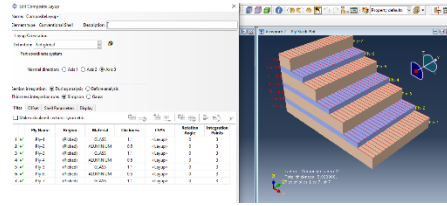

Step 2



Step 3

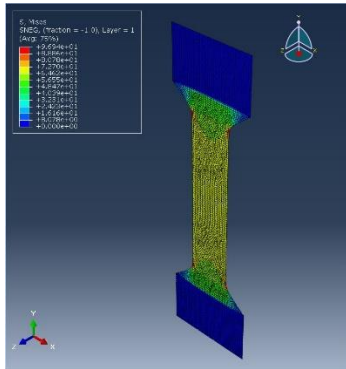

Sample 3:
Step 1

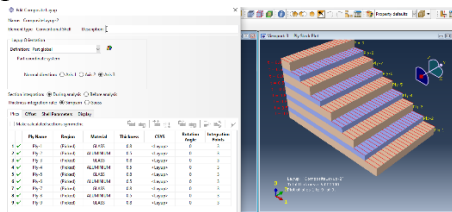

Step 2

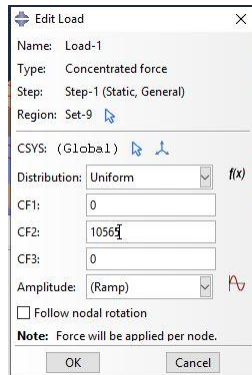

Step 3

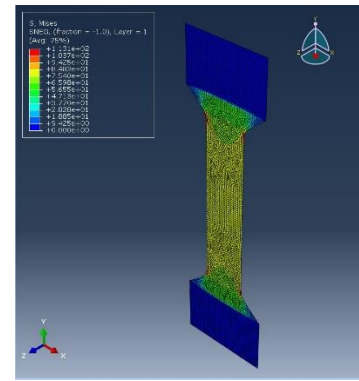

2. Flexural test:
Sample 1:

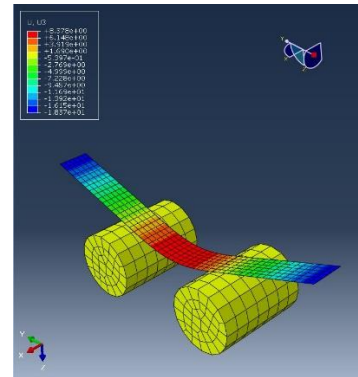

Sample 2

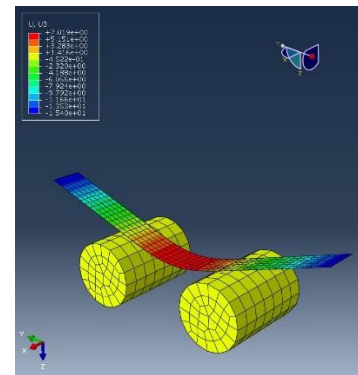

Sample 3

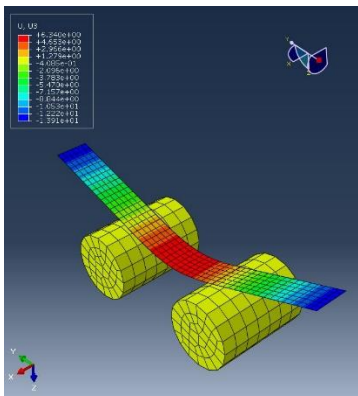

Analytical Results:

S.NO	TEST	TYPE 1	TYPE 2	TYPE 3
1	Tensile test in MPa	113.1	96.9	83.53
2	Flexural test bending in mm	8.3	7.0	6.3

Comparing the Experimental and Analytical results:

S. N O	TEST	TYPE 1		TYPE 2		TYPE 3	
		Exp	Ana	Exp	Ana	Exp	Ana
1	Tensile strength in MPa	109.9	113.1	97.04	96.9	82.03	83.53
2	Flexural load in KN	8.4	8.3	7.4	7.0	6.2	6.3

VI. CONCLUSION

It is observed that when the Glass Fiber Thickness Fraction (GFTF) is increased the tensile strength is increased. The tensile strength increased by 18.29. When the Glass Fiber Thickness Fraction (GFTF) increased by 13.30. When the Glass Fiber Thickness Fraction (GFTF) increased for 0.75 to 0.83. This is because glass Fiber Reinforced Epoxy has more tensile strength than Al.

It is observed that when the Glass Fiber Thickness Fraction (GFTF) is increased the Flexural Load is increased. The Flexural Load increased by 14.69. When the Glass Fiber Thickness Fraction (GFTF) increased by 14.48. When the Glass Fiber Thickness Fraction (GFTF) increased for 0.75 to 0.83. This is because glass Fiber Reinforced Epoxy has more Flexural Load than Al.

It is observed that when the Glass Fiber Thickness Fraction (GFTF) is increased the Compression Test is increased. The Compression Load increased by 3. When the Glass Fiber Thickness Fraction (GFTF) increased by 4.40. When the Glass Fiber Thickness Fraction (GFTF) increased for 0.75 to 0.83. This is because glass Fiber Reinforced Epoxy has more Compression Load than Al.

It is observed that when the Glass Fiber Thickness Fraction (GFTF) is increased the Double shear Load is increased. The Double shear Load increased by 39.47. When the Glass Fiber Thickness Fraction (GFTF) increased by 3.725. When the Glass Fiber Thickness Fraction (GFTF) increased for 0.75 to 0.83. This is because glass Fiber Reinforced Epoxy has more Double shear Load than Al.

REFERENCES:

[1] Nicholas T. Kamar, Mohammad Mynul Hossain, Anton Khomenko, Mahmood Haq, Lawrence T. Drzal, Alfred Loos. "The effect of graphene presence in flame retarded epoxy resin matrix on the mechanical and flammability properties of glass fiber-reinforced composites" *Composites: Part A* 53 (2013) 88-96

[2] T.K. Bindu Sharmila, Jolly V. Antony, M.P. Jayakrishnan, P.M. Sabura Beegum, Eby Thomas Thachil. "Mechanical, thermal and dielectric properties of hybrid composites of epoxy and reduced graphene oxide/iron oxide".

[3] Sanjay M.R, Arpitha G.R, B Yogesha. "Study on mechanical properties of natural glass fiber reinforced polymer hybrid composite, a review". *Materials today proceedings* 2015.

[4] S. Channabasavaraju, Dr. H. K. Shivanand, Santhosh Kumar .S. "Evaluation of Tensile and Flexural Properties of Polymer Matrix Composites". *International Journal of Modern Engineering Research (IJMER)*, Vol. 3, Issue. 5, Sep - Oct. 2013 pp-3177-3180.

[5] ANSHIDA HANEEFA, PANAMPILLY BINDU, INDOSE ARAVIND AND SABU THOMAS. "Studies on Tensile and Flexural Properties of Short Banana/Glass Hybrid Fiber Reinforced Polystyrene Composites". *Journal of COMPOSITE MATERIALS*.

[6] C.M. MANJUNATHA, S.SPRENGER, A.C. TAYLOR AND A. J. KINLOCH. "The Tensile Fatigue Behavior of a Glass-fiber Reinforced Plastic Composite Using a Hybrid-toughened Epoxy Matrix". *COMPOSITE MATERIALS*, Vol. 44, No.17/2010.

[7] Chensong Dong and Ian J Davies. "Flexural properties of glass and carbon fiber reinforced epoxy hybrid composites". *J Materials: Design and Applications* 227(4) 308-317.

[8] David H. Allen "Structural Analysis, Aerospace" *Journal on Encyclopedia of Physical science and technology* 3rd edition 2003.

[9] Japan.s.Daniel.L. and Theodor .k.2005. "Finite Element Analysis of Beams", *Journal of Impact engg.* Vol31, Pages 861-876., Pages155-173.