

# *Production and characterization of Fired Clay Bricks with Admixture of Palmyra Fruit Fiber and Evaluated by Ansys*

Ravi chettu Laxman<sup>1</sup>  
Dept of mechanical engineering  
PG student at anurag engineering college  
Email:ravichettulaxman319@gmail.com

Kancharla Bullibabu<sup>2</sup>  
Dept of mechanical engineering,  
Research scholar at KLUUniversity &  
Asst professor at Anurag Engineering college  
,kodad- 508206, IndiaKodad-508206, India.  
Email:phinehas310@gmail.com

Jangala Sandeep<sup>3</sup>  
Dept of mechanical engineering  
UG student of anurag engineering college  
kodad-508206, India  
Email:sandeepjangala1996@gmail.com

Divvela Pradeep<sup>4</sup>  
Dept of mechanical engineering  
UG student of anurag engineering college  
kodad-508206, India  
Email:divvelapradeep@gmail.com

**Abstract:** - The effect of compositions of Palmyra fruit fiber admixture on thermal stresses and other mechanical properties of Clay were investigated. The raw clay gotten from Suryapet in Telangana state. First processed to very fine particles of clay were also dried at atmosphere temperature to remove moisture present. A composite mixture of this dried Palmyra fruit fiber with the processed clay was made at various proportions of the Palmyra fruit fiber, with a little addition of water for plasticity. Samples of rectangular dimensions were then produced from the mounting press by the process of compaction with a very high pressure. The samples were dried and then finally fired in the furnace at 1000°C for a final curing. Properties which include thermal shock resistance, bulk density, cold crushing strength and porosity were obtained by the appropriate standard test methods. The microstructures of the fired samples were characterized with Trinocular Microscope.

The results show that the amount of Palmyra fruit fiber admixture affects the properties variously; porosity and thermal resistance increases with percentage increase in Palmyra fruit fiber, thermal and mechanical properties were also evaluated by ANSYS.

**Keywords:** *Palmyra fruit fiber, Clay, Trinocular Microscope and ANSYS.*

## 1. INTRODUCTION

In this paper main objective is development

of thermal insulated construction material by admixture of Palmyra fruit fiber. Main reason for adaption of fiber it consist excellent thermal resistive properties and cohesive with clay. So mainly in the India human beings are unable to bare the air conditioning systems with peak electric power consumption, because of necessitous economical conditions. So these unsustainable conditions are consideration in this research and focus on to decrease the heat transfer rate through the wall due to change the composition of the constructional material by admixture with fiber. Mainly in the India construction materials are clay and cement bricks. These bricks are very cheap compared to other hallow bricks. The strength of the wall is also good. There is good demand for clay bricks in developing countries like India .Due to increasing urbanisation many houses and industries to be construct as per the requirement of the people. Energy saving is an important issue in the world because of both economic and environmental concerns. Consumption of energy from buildings constitutes about 30% of total consumption with about half of this lost through the walls. Indian standard states that, depending on the location and climate, walls should be made of material with a heat transfer coefficient of 0.41–0.72 W/m<sup>2</sup> K, the lower the better. If the thermal resistance is further improved, then heat loss will be decreased and, hence many brick manufacturers are seeking to produce such materials. Earthenware clayey raw material is generally used with few pre-

treatment steps for extruded perforated bricks. Firing temperature is generally of the order of 1100°C. The product consists of vertical perforations to reduce heat transfer through the brick. There are two different thermal conductivity values of these bricks: first involves the bulk of the material constituting the walls, while the second

involves thermal conductivity of the entire product consisting of large vertical holes of rectangular cross-section.

The Palmyra fruit fiber as reinforcement in a clay matrix for making composite clay bricks and the fibers are to be cut and crushed to micron sizes for proper mixing with the matrix of clay to develop composites Hand moulding technique is employed to manufacturing composite clay bricks. Along developing suitable moulds for Mechanical characterization.

### 1. RAW MATERIALS

Mainly in this investigation Palmyra fruit fiber and clay are the main source materials to manufacturing of composite clay brick. These materials are made up in required fine particles to preparation of laboratory test samples.

#### 1.1 Clay Preparation

Granulated raw clay made as a powder with light duty industrial mortar. These clay powders were sieved for fine powdered particles .i.e. 300µm sieve size. These fine powders dried at atmospheric temperature for complete removal of moisture content, which is present in clay powder.

#### Palmyra Fruit Fiber Preparation



Fig.1. Fiber Preparation for Required Sizes

After separation of marrow from the Palmyra fruit, remained fiber have mucus nature. For the removal of mucus content from the fiber washed out 8 times with hot and pure water. For complete removal of water content from the fiber need to dry at atmospheric temperature. These dried fibers were crushed for required sizes i.e.150µm and passed through the sieve shaker.

### 3. Chemical properties of Palmyra fruit fiber

Chemical composition on Dry weight	Percentage based
Ash	0.64 ±0.06
Holocellulose	68.52±1.38
Cellulose	37.01±0.92
Lignin	18.54±0.58
Pentosan	28.51±1.10
1% NaOH solubility	44.68±2.33
Hot water	21.36±2.30
Ethanol-benzene	4.26±0.58

Table 1. Some chemical compositions Palmyra fruit fiber

The chemical composition of Palmyra palm fruit fibers is shown in Table 1. The ash content of the fibers is 0.64%. This is lower than those of non-wood fibers such as rice straw with 9.2% (Rodriguez et al., 2008), jute leaf with 8.8% (Basak et al., 1996), kenaf with 4% (Khristova et al., 2002) and bagasse with 1.5% (Khristova et al., 2006). Chemically, Palmyra palm fruit fibers are rich in holocellulose (68.52%) and cellulose (37.01%).chemical properties of Palmyra fruit fiber. from W. Sridach [30] and Z.Qiu et al [31].

### 3.EXPERIMENTAL PROCEDURE

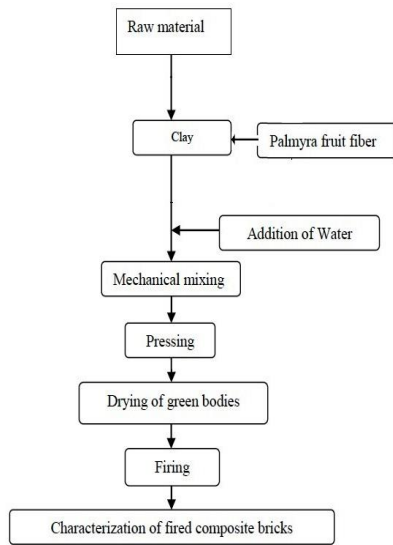

#### 3.1 Procedure for clay brick preparation

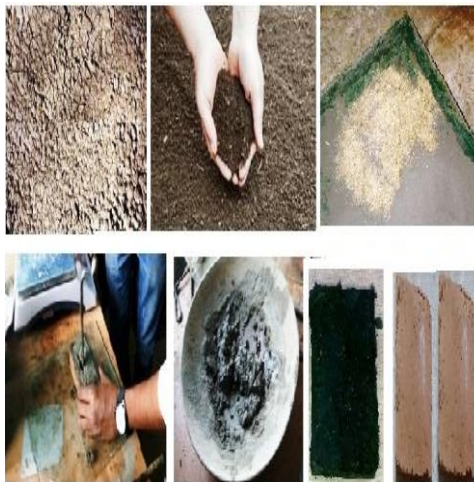

Fig.2. preparation of composite clay brick samples

Brick raw materials clay and Palmyra fruit fiber and were dried at atmospheric temperature. Then they were powdered by centrifugal pulverized mill. Finely prepared dry fiber powder blended with fine soil in centrifugal mixing upto 850rpm for 40 min. These mixtures were compacted by manual force for rectangular shaped specimens. The prepared specimens were dried at room temperature up to one week. Dried specimens were fired in laboratory electrical furnace at the rate of 4.5°C/m until 800 °C and at 5.5°C/m until 1100°C. Fired products were characterized for mechanical properties like compressive strength, Microstructure varied by

Trinocular Microscope and Temperature and weight change by the TGA.

#### 3.2 Brick Microscope structures by Trinocular

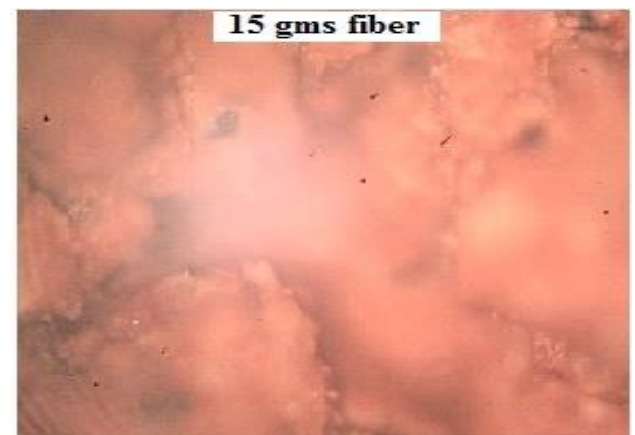
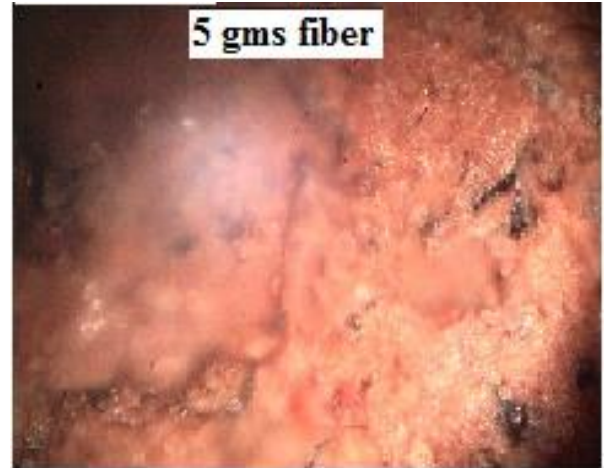

Fig.2. 10, 15&20grams fiber content brickstructure

### 3.3 Thermo Gravimetric Analysis On Bricks

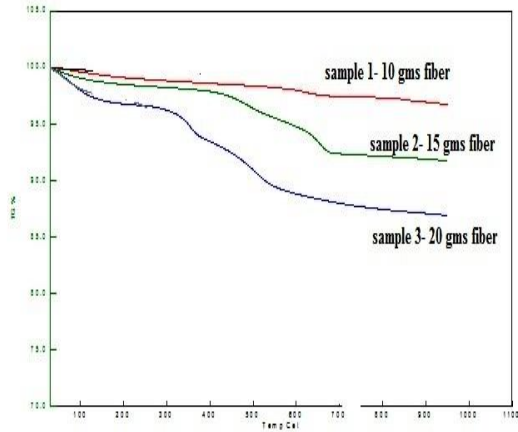

Fig.3. Thermo gravimetric analysis (TGA) Temperature Vs Weight Changes

### 4. COMPRESSION TEST ON BRICKS



Brick no	Composition	Load (KN)	Breaking stress (KN/m <sup>2</sup> )
1	10gms Palmyra fruit fiber	7.35	1470
2	15gms Palmyra fruit fiber	5.88	1176
3	20 gms Palmyra fruit fiber	4.7	940

Fig.4.compression testing procedure and results of different composite bricks

### 5. STRUCTURAL ANALYSIS OF BRICK

Structural analysis is carried out in ANSYS (Finite Element package). Finite Element Analysis is divided into three sub steps:

- 1) Pre-Processor
- 2) Solver
- 3) General Post-Processor

#### Material Properties

Brick is fabricated with clay and Palmyra fruit fiber composite. Therefore the below mentioned material attributes are defined for the element which are derived from experimental analysis.

#### Meshing

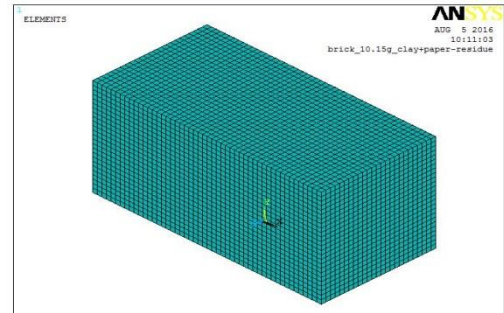

Fig.4. Meshing propagation

### 5. STRUCTURAL ANALYSIS OF CLAY AND PALMYRA FRUIT FIBER COMPOSITE BRICK

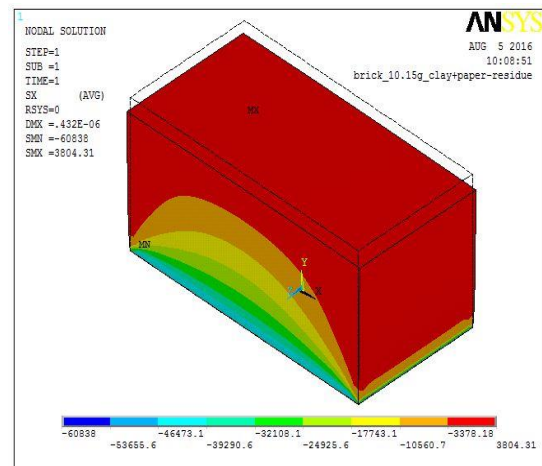

Fig.5. stress Distribution along X direction

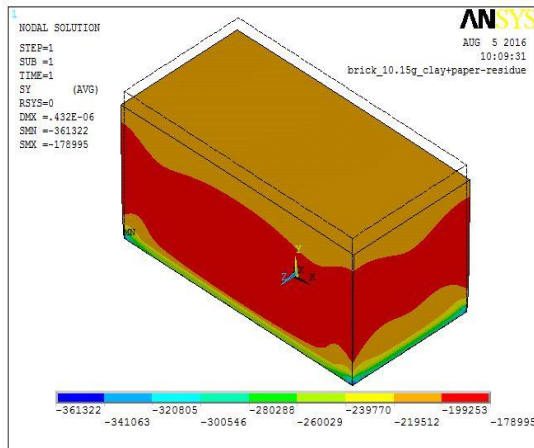

Fig.6. stress Distribution along Y-direction

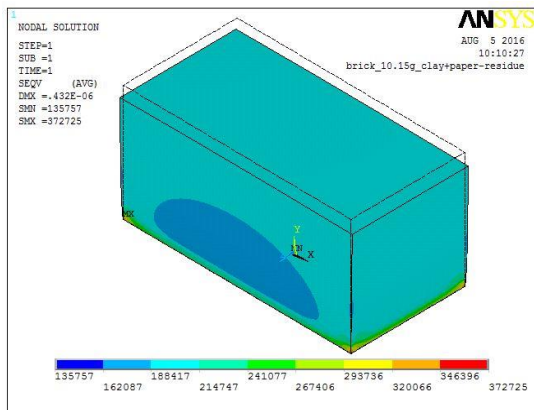

Fig.7. Von – Mises stress distribution

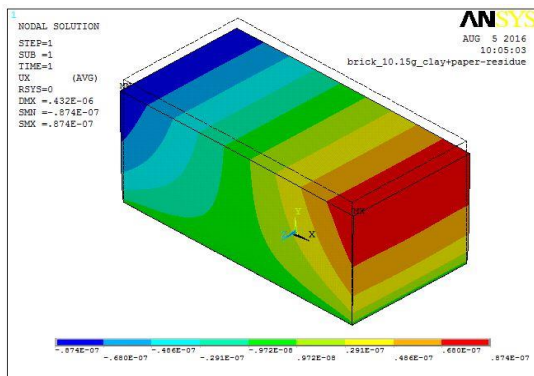

Fig.8. Deformation along X direction

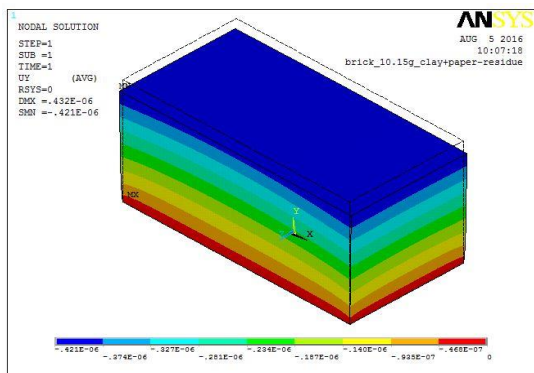

Fig.9. Deformation along Y direction

## 6. RESULTS AND DISCUSSIONS

In this paper an investigation on thermal resistance of a construction material containing Palmyra fruit fiber particles was presented. Results were examined according to combination-specialty properties, and specialties of Palmyra fruit fiber bricks at various weights were determined in experiments. Unit weight of Palmyra fruit fiber brick was calculated less than standard brick that has unit weight of  $1540 \text{ kg/m}^3$ . Unit weight of a lightweight material must be lower than  $1000 \text{ kg/m}^3$ . As the replacement ratio of. Unit weight of pressed Palmyra fruit fiber and clay were calculated as  $111.6$  and  $1238 \text{ kg/m}^3$ , respectively

The experimental investigation revealed that the addition of Palmyra fruit fiber particles reduces the material unit weight; furthermore, thermal resistance of the composite has been improved. The thermal insulating effect of particles is most attractive and indicates a high and promising potential for development.

## 7. CONCLUSION

In order to development of Palmyra fruit fiber useful for an admixture with brick products. In this composite bricks Identified that little shrinkage ( $1.48\text{-}2.35\%$ ) occurred in the clay brick and also in the cement brick ( $1.65\text{-}2.87\%$ ) that contained Palmyra fruit fiber while the brick without admixture shrunk by about  $3.9\%$ . Their fired densities varied between  $1.79$  and  $1.23 \text{ g/cm}^3$ , which correspond to a decrease of  $27\%$ , when compared to the density of the brick without admixture. Apparent water absorption values were increased with increase in Palmyra fruit fiber addition. Pressing direction of the bricks and shape of the pores in samples has a considerable effect on mechanical strength. Due to increase the content of Palmyra fruit fiber and palm fruit fiber addition, then compressive strength of the samples decreased but compressive strength of the samples was still higher than the standard strength values. Their thermal conductivity values decreased by up to  $40\%$  while required mechanical strength could be maintained. Results indicated that the Palmyra fruit fiber could be easily utilized as pore-forming additives into brick bodies to facilitate production of thermal insulated bricks. In this structural analysis, we have

modeled a clay and Palmyra fruit fiber composite brick 10.15g (50% +50%) and structural analysis is carried out to observe the stress distribution and deformation patterns in 3 dimensionally which is induced due to 200 kPa compressive pressure load. It is observed that the magnitude of stress and displacements are maximum in the Y direction due to compressive load. Finally, by FEA simulation we understand stress distribution and deformation in clay and Palmyra fruit fiber brick.

### 8. References

- [1] **Dokuz Eylul** University, Department of Environmental Engineering, Analysis Report, March 9, 2006.
- [2] **C.M.F. Vieira, R. Sa´nchez, S.N. Monteiro**, Characteristics of clays and properties of building ceramics in the state of Rio de Janeiro, Brazil, Construction and Building Materials 22 (2008) 781–787.  
WEB\_3, 2008, <http://www.fbt.ie/poroton.html>.
- [3] **Koronis. G., Silva. A., Fontul. M.** “Green composites. A review of adequate materials for automotive applications,” International Journal of Mechanical Sciences, Vol.52 (2010), pp.874–891.
- [4] **[Ahmed, A.S., Alam, M.A., Pice, A., Rahman, M.R. and Hamdan, S.** “Study of Physical and Mechanical Properties of Oil Palm Empty Fruit
- [5] Bunch Fiber Reinforced Polypropylene Composites.” Jou. of Energy and Environment, Vol.2, (2010) , pp.16-21
- [6] **Nicollier, C., and Mutasher, S.A.** “Failure prediction on advanced grid stiffened composite cylinder under axial compression,” Composite Structures, Vol.93 (2011), 1939–1946.
- [7] **Jawaid, M., Abdul Khalil, H.P.S., Bhat, A.H., and Abu Baker, A.** “ Impact Properties of Natural Fiber
- [8] Hybrid Reinforced Epoxy Composites,” Advanced Material Research, Vol.264-265, (2011) , pp.688- 693.
- [9] **Rao. C.H., Kundalwal. S.I. and Ray, M.C.** “Sensing of Damage and Healing in Threedimensional Braided Composites with Vascular Channels,” Composites Science and Technology, Vol.72 (2012), pp. 1618–1626.
- [10] **Toutanji. H, Li. F. and Cheng. H.M.** “Effective Properties of a Novel Continuous Fuzzy-fiber Reinforced Composite Using the Method of Cells and the Finite Element Method,” European Journal of Mechanics of Solids, Vol. 36 (2012), pp. 191-203.
- [11] **R. Velmurugan, V. Manikandan** // Indian Journal of Engineering & Materials Sciences 12 (2005) 563.
- [12] **V. Manikandan, R. Velmurugan** // Materials Science 7(2) (2011) 94.
- [13] **M Thiruchitrabalam, D Shanmugam** // Journal of Reinforced Plastics and Composites 31(20) (2012) 1400.
- [14] **Adavi Balakrishna, Damera Nageswara Rao, Adapa Swamy Rakesh** // Composites Part B: Engineering 55 (2013) 479.
- [15] **Budrun Neher, Md. Mahbubur Rahman Bhuiyan, Humayun Kabir, Md. Rakibul Qadir, Md. Abdul Gafur, Farid Ahmed** // Composite Materials Sciences and Applications 5(1) (2014) 39.
- [16] **D. Neher, Md.A. Gafur, M.A. Al-Mansur, Md.M. Rahman Bhuiyan, Md.R. Qadir, F. Ahmed** // Materials Sciences and Applications 5 (2014) 378.
- [17] **M. Jawaid, Othman Y. Alothman, M.T. Paridah, H.P.S. Abdul Khalil** // International Journal of Polymer Analysis and Characterization 14(1) (2014) 62.
- [18] **C. Mahesh, B. Kondapanaidu, K. Govindarajulu, V. Balakrishna Murthy** // International Journal of Engineering Trends and Technology 5(5) (2013) 259.
- [19] **P. Padmavathi, C.J. Rao** // International Journal of Research in Aeronautical and Mechanical Engineering 2(12) (2014) 24.
- [20] **V. Arumuga Prabu, V. Manikandan, M. Uthayakumar** // Materials Physics and Mechanics 14 (2012) 57.
- [21] **V. Arumuga Prabu, V. Manikandan, M. Uthayakumar** // Materials Physics and Mechanics 15 (2012) 173.
- [22] **V. Arumuga Prabu, V. Manikandan, M. Uthayakumar** // Journal of Advanced Microscopy Research 8 (2013) 199.
- [23] **W.Sridach/Songklanakarinn**  
**J.sci.Technol.**329(2),201-205,2010.
- [24] **Z.Qiu et al./Bioresource Technology** 117(2012) 251-256.
- [25] **Duman V, Mladenovic A, Suput JS.** Lightweight aggregate based on waste glass and its alkali-silica reactivity. Cement Concrete Res 2002;32:223–6.
- [26] **Kearsley EP, Wainwright PJ.** The effect of high fly ash content on the compressive strength of foamed concrete. Cement Concrete Res 2001;31:105–12.
- [27] **Savastano Jr H, Warden PG, Coutts RSP.** Brazilian waste fibres as reinforcement for cement-based composite. Cement Concrete Comp2000;22(5):379–84.
- [28] **V. Arumuga Prabu, V. Manikandan, M. Uthayakumar** // Materials Physics and Mechanics 15 (2012) 173.
- [29] **V. Arumuga Prabu, V. Manikandan, M. Uthayakumar** // Journal of Advanced Microscopy Research 8 (2013) 1992
- [30] **W.Sridach/Songklanakarinn**  
**J.sci.Technol.**329(2),201-205,2010.
- [31] **Z.Qiu et al./Bioresource Technology** 117(2012) 251-256.