

An Advanced IOT based Antitheft Security System with Video Monitoring Facility

V.Krishnaveni^[1], A.Priyanga^[2], V.Vidya^[3], G. GaneshKumar^[4]
^{[1][2][3]}UG Student, ^[4] Assistant Professor, ^{[1][2][3][4]} Department of CSE
Sree Sowdambika College of Engineering, Aruppukottai-626 101

ABSTRACT

Security is a too much important thing to be concerned in our day-to-day life. Everyone wants to be secured as much as possible. Knowing our home or shop is secure provides us peace of mind. We know now a day's theft has become a major issue. In this project we design an advanced electronic security system by using small PIR and IR sensors built around the Node MCU controller. PIR sensor sense the presence of intruder & Controller reads the signal from sensors and if intruder is detected, it compares the detected image with predefined images in the database then it turns on the buzzer as well as making a notification to predefined number. At the same time the video of intruder can also be monitored and make them anesthetic.

KEYWORDS: smart monitoring, social enterprise, open source technologies, internet of things, low-cost sensors

1. INTRODUCTION

We have designed an interesting and cost effective security alarm for highly authentication places. This Gadget helps you to protect your areas from thieves. In this project we are going to use a Node MCU, P.I.R Sensor module, LCD, DVR device and some other components. This Project can either powered with 9V Battery or with U.S.B of your computer. This is a basic motion-sensing alarm that detects when someone enters the area. When an intruder is detected, it compares the detected image with predefined images in the database then it activates a siren. Our body generates heat energy in the form of infrared which is invisible to human eyes. But it can be detected by electronic sensor. This type of sensor is made up of crystalline material that is Pyroelectric. In this project, we are using P.I.R. Motion Sensor Module as an infrared sensor that generates electric charge when exposed in heat and sends a signal to Node MCU. According to level of the infrared in front of sensor, Node MCU displays the status on L.C.D and starts buzzing speaker and glows the L.E.D. A simple program is running on Arduino IDE which checks sensor if anything is moved or new object has been detected.

2. BACKGROUND

2.1 Smart Monitoring

Surveillance, from homes to huge industries, plays a significant role in the fulfillment of our security. Aspects such as burglary and theft have always been a predicament. In large industries, personal safety refers to the monitoring of the people's shifting information like activities and behavior to protect, manage, and influence personal details. Surveillance refers to observing over from a distance by use of electronic equipment like CCTV cameras.

Individuals should have the choice to live without fear and the confidence to carry out any business without fear of insecurity. The system created in this study offers security while maintaining the privacy of individuals since only one person can view it. Additionally, it uses a simple circuit. The system uses Node MCU for its operations, allowing the transmission of images to a smart phone. The traditional surveillance system is associated with various challenges and costs associated with energy use. An energy effective moveable system is preferable, and it can capture images during an occurrence of burglary. The system allows people be more independent and feel secure in their everyday activities. Further, it sends out an alert signal, making it better than the currently used surveillance systems. Project implementation is simple.

The homeowner/ company place a camera in a particular area that needs monitoring to ensure security. The system allows the user to access and monitor security from different locations, even remote areas. The user can monitor the remote surveillance system using a smart phone with connected internet availability. The system is useful for projects targeting security setups limited to a specific location, but whose security is monitored from separate locations. The primary objective of this study is to create a security based system which is more affordable and flexible as far as location is a concern and the specific goals are;

- a. To design a simple, cost-effective and easy to implement PIR security based system using the existing

technology.

b. To design PIR security based system for persons who might want to control their work, office, or home from a distance.

c. To fabricate PIR security-based system. The system is small in size, portable, and stand-alone with its power source making it simple to implement. It also possesses energy for instant alert and is cost-effective for both residential and personal use.

2.1.1 Requirements:

1. Node MCU
2. PIR sensor
3. DC Motor
4. Smart phones
5. Arduino IDE
6. chloroform
7. DVR device
8. Power supply
9. Arduino IDE
10. LED and LCD

2.1.2 METHODOLOGY:

With the growth in wireless technology, the danger of attacks is also increase. For making wireless technology secure cryptographic methods can be used. But cryptographic methods can defense outside attacks. Intrusion detection system monitors traffic of the sensor nodes and detect abnormal behavior of the nodes. The major approaches that an Intrusion Detection System can used to specify attacks are [8]:

1. Anomaly Detection: this approach checks whether the behavior of the nodes can be consider normal or not. The approach first describes the feature of the normal node. After that any activity that is not describe into the feature behavior of node is consider as anomalous. Advantage of this method is that it can detect novel attacks. And the disadvantage of this method is false alarm rate is high.

2. Misuse Detection: this is rule-based method, rules are define on the basis of the signature of known attacks. The behavior of nodes is compare with known attacks. and if behavior match with predefined rules then attack detected. This method works efficiently if the attack is known, but fails if the attack is novel attack.

3. Specification-based Detection: this method is combination of anomaly detection and misuse detection. This method focus on discovering deviation from normal behaviors. In this mechanism the behavior that can be consider normal is defined manually by human. Drawback of this approach is manually defining the all specification.

The methodology used in the proposed model is to develop a prototype model of a house, in the prototype an interface of mercury switches, motion detectors, and WiFi module is being developed with a microcontroller. The communication between the microcontroller and other

components of the system takes place serially. The microcontroller continuously receives data from the mercury switches and the motion detectors, takes decision on the basis of the readings collected onto the microcontroller. On intrusion the microcontroller will generate a message to the owner or to a set of predefined numbers stating the sort of an intrusion that has been made.

2.1.3 ADVANTAGES:

- 1) Security is automated.
- 2) Economy of country is saved.
- 3) Alert can be generated through GSM even in the case of failure of internet.
- 4) Does not affect the power transfer capability of line.

2.2 Scope of Project:

This project will focus on programming to lock or unlock the door via PC. Security systems have been around for a very long time, even before the introduction of microcontrollers. Over the course of all that time, they have come quite a long way.

They have gone from being simple analog circuits with key switches and mechanical bells to being sophisticated digital systems that can automatically report alarms and status information to a alarms and status information to a monitoring center and even offer home automation to some extent. However, many modern security systems have some hidden shortcomings. For instance, one system that is advertised as having many innovative features still uses a POTS (“plain old telephone service”) line for monitoring by default (ElkProducts). While reporting alarms in this fashion may be reliable, it can also be quite slow, not to mention it cannot be used in homes that do not have landline phone service (which, with cell phones becoming so common, is seen more and more often). Other modern systems get around the no-landline limitation by using an internal “virtual cell phone” of sorts to emulate POTS-based reporting (“Home Security Systems Comparison”). Not only is this still phone-based reporting, it also introduced the cost of needing to connect to the cellular network, and it can be affected by poor cellular reception. A better method of reporting alarms is IP-based reporting, where the alarm system uses an Internet connection to report alarms to the monitoring center. Some alarm systems do offer this capability, but it hasn't caught on as much as one would think (Elk Products). By using IP-based reporting, the alarm system can potentially send a detailed alarm report to a monitoring center in a split-second, allowing for authorities to be dispatched sooner in a potentially life-or-death situation. Additionally, with any alarm system, there is always that one feature you wish it had. Be it an output that can be used in a specific situation, the ability to control a certain device, or some other feature, there often seems to be something that the manufacturer forgot about. For instance, my family was getting a hold-up alarm installed in the house,

and we wanted there to be an LED that would light up when the system needed to be reset. However, it turned out that because the system was configured for the panic button to trigger a silent alarm (i.e. only report it to the monitoring company; don't do anything else), it would not turn on any of its outputs when that alarm was in its memory, so there was no way to know if it needed to be reset or not.

2.2.1 System Architecture:

The system comprises two units. The microcontroller unit consists of four sensors and the WiFi module. The outputs of all the sensors are connected to ADC. One IR is connected at window and other is at door. The data from the sensors is continually processed by the microcontroller and an alert is sent to the mobile station if something is sensed or something reaches beyond the limit in case of a motion detector. These three units of the system are responsible for the security of a home.

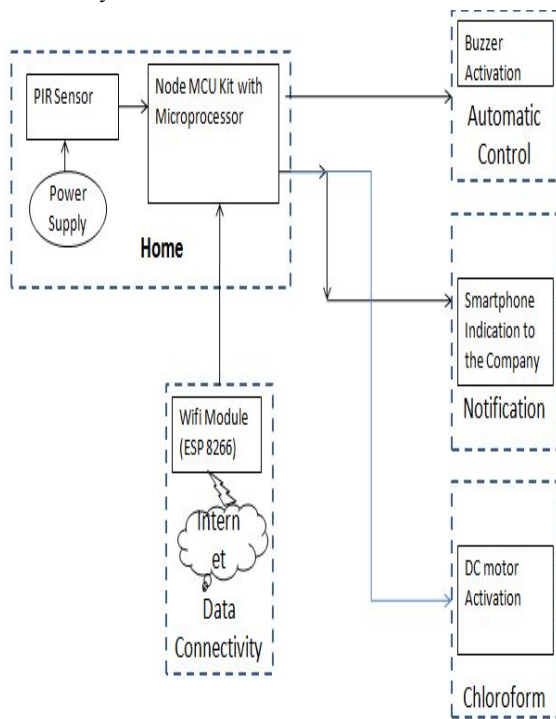

Fig: Block diagram

2.2.2 PROBLEM IDENTIFICATION

The door was not equipped with anti-theft system. Most people only take the whole home security system into account. This project focuses specifically on the room security system, and nothing to do with the home security system. This project is a simple version of security system, and the scope was not so big as well. Door security is the main element which will be taken into consideration. Door security system is important nowadays. The whole building security system or civilian home security system is expensive.

Most security systems available in the market

nowadays are complicated, and installation of the system will cost another amount of money to be invested in order to have a good security system. A variety of security devices for deterring, detecting and identifying offenders or intruders can be found. However, very few provide a working relationship to a room.

An intrusion deterrent device which activates a water spraying system has been invented. A triggering mechanism for a tear-gas canister was introduced for the purpose of security and protection, but this idea did not have a working relationship to a room. Security devices to identify the bank robbers using the spray gun to discharge a scent which can be detected by the dog have a working relationship to a room. Device was installed inside the room, mounted at the ceiling. This project will implement a simple anti-theft security system for lecturer's room that has a clear relationship to a room to fulfill this void. This project will also demonstrate the idea of port programming and PC-based control system. Usage of computer software to control security system was widely accepted, and only authorized person will have access to the system which determines the room security. This feature can avoid unauthorized person to take control of the system or gain access to the security system. This is very important to make sure that the system is secure.

2.2.3 Objectives of Project:

This project was done in order to achieve some objectives at the end of the project timeline. Here is the list of this project objectives:

1. To develop programming and software using any available software to program the security system for the room door with auto-lock feature.
2. To demonstrate and apply the idea of computer port programming and PC-based control system.
3. To develop Graphical User Interface (GUI) which will be used by the user to manage and control the system.
4. To integrate the door system with personal computer using any available Communication port.
5. To design and integrate hardware with electronic and electrical elements which will be used to simulate electromagnetic door system.

3. PROPOSED SYSTEM

We plan to use Arduino Uno, the open source and user friendly hardware, with Wifi connectivity portable to laptops and PCs

The thief entry is monitored by the above setup placed inside the home

Once the entry is detected a notification will be sent to the owner

The video can be monitored through the mobile phone.

If the person is unknown the DC motor will be activated from remote to spray the chloroform.

3.1 Need of Security System:

Avoiding a break-in at your home is much easier than you might think. Taking a few simple steps to make your property seem like an unappealing target is quite often enough to make sure a criminal who happens to be eyeing your home decide it's not worth the effort. Criminals tend to be incredibly lazy, and most can't be bothered to put in the extra work required to circumvent even the most basic home security systems.

This is great news for you since it means that investing in a home security system that is installed and monitored by experienced professionals is enough to keep most burglars from ever approaching your home. The very real threat of getting caught sneaking around on property that is under surveillance can go a long way towards protecting your home, your valuables, and your family. In fact, homes that don't have a security system are three times more likely to be broken into than homes that do have a security system of some type in place. But of course, a home security system is so much more than just a scare tactic. Today's systems offer a ton of great options to fit the needs of both your home and your lifestyle, with mobile apps and other add-ons giving you more ways to monitor and interact with your security system. Having that sticker or yard sign in place that warns would-be intruders that your home is protected is just the beginning.

There are two basic types of alarm systems available; monitored and non-monitored. Monitored systems are the type of security solution most people picture when they think about home security. These are the systems that are provided by a security company that employs a team of people whose job is to keep tabs on your property and contact both you and the proper authorities when an alarm is triggered.

Many of these systems have two-way communication built into the security wall panel or other devices, allowing you to speak directly to a representative who can help you handle the situation quickly. In the interest of prioritizing your personal safety, some security companies will contact you through text message or email to alert you to a suspected security breach. Depending on the type of system you choose, your security solution will have a battery backup in place which will allow the system to alert the company's monitoring station in the event of a power outage. That way, you'll never have to worry about your system failing you when you need it most.

A high decibel alarm is a standard part of both monitored and non-monitored systems, emitting a shrill alarm sound when a motion sensor or other alert is triggered. The noise is usually enough to spook a burglar into leaving, stopping a break-in before they have a chance to take anything. If you have an off the shelf, non-monitored system in place, the alarm is your signal to call the authorities. Again, depending on the solution can choose.

Non-monitored systems are becoming more sophisticated, with many offering added features and capabilities that are almost able to match what a professional security system offers. Cameras and other high-tech options make building a more comprehensive system a possibility, and remote self-monitoring through mobile apps gives you control over activating and deactivating alarms. However, these non-monitored systems rely fully on you. If you miss an alert, there is no one watching your home who can send authorities to handle any situation that comes up.

The single biggest advantage of having a professionally monitored home security system installed in the peace of mind it provides. Whether you're at work, out running errands, on vacation, or asleep in your bed, your home and your family are protected. Systems that combine security with fire or water detection offer protection against non-criminal damage, and ensure that the right people are sent to help you as soon as an alert is triggered. Systems with two-way communication can also act as a quick way to signal help in the event of a medical emergency.

Protecting your home is a big job, and require more than just remembering to lock your doors when you leave for the day or turn in for the night. The wide range of home security system solutions available to today's home owners exists because these solutions are effective, and have proven to be the best way to keep you and your family safe from intruders and other potential dangers.

4. CONCLUSION AND FUTURE RESEARCH:

The security system described in this project is capable of detecting intruders. The system informs the authorized owner of an unauthorized intrusion via SMS no matter where the person is, except if the person is in the region where there is no network coverage at the time of intrusion. The commonly available systems today are one where the intrusion is detected via alarms making out sounds. The system is very beneficial for people who wants to safe guard their properties and restrict access. This system is very affordable and easily operated, so that anybody whether rich or comfortable, young or old can make use of this system.

Thus, we have designed a home security alarm system using Arduino and PIR motion sensor, which is handy, portable, cost-effective and highly effective as well. Such alarm systems are hugely in demand for security purposes, and thus the given system can be proved useful and effective in view of the above features.

4.1 Future Scope:

- We can add a keypad to arm or disarm the alarm
- We can determine the position of the intruder and then send a SMS to the concerned authorities.

12. REFERENCES:

- [1] Audette, W. E., Kynor, D. B., Wilbur, J. C., Gagne, J. R., & Peck, L. "Improved Intruder Detection Using Seismic Sensors and Adaptive Noise Cancellation" 2009.
- [2] Ayush Agarwal, R.C. Joshi, "WSN and GSM based Home Security Systems", IJCA Proceedings on International Conference on Recent Advances and Future Trends in Information Technology (iRAFIT 2012), Number 2.
- [3] I. Syam Krishna, J. Ravindra, "Design and Implementation of Home Security System based on WSNS and GSM Technology" International Journal of Engineering Science and Technology" Volume 2, Special Issue 1, Page 139-142.
- [4] V. Karri and J. S. Daniel Lim, "Method and Device to Communicate via SMS After a Security Intrusion", 1st International Conference on Sensing Technology, Palmerston North, New Zealand, (2005) November 21-23.
- [5] Z. Bing, G. Yunhung, L. Bo, Z. Guangwei and T. Tian, "Home Video Security Surveillance", Info-Tech and Infonet, 2001, Proceedings, ICII 2001-Beijing. 2001 International Conference, vol. 3, pp. 202-208.
- [6] Mahmud S.A, Mohameed G.A, "development of a simple sound activated burglar alarm system" Leonardo journal of sciences. Issue 9, July-Dec 2006.
- [7] Prakash Kumar, Pradeep Kumar, "Arduino Based wireless intrusion detection using IR sensor and GSM", International Journal of Computer Science and Mobile Computing, Vol 2, Issue 5, May, 2013.
- [8] R. Sharma, K. Kumar, and S. Viq, "DTMF Based Remote Control System," IEEE - International Conference ICIT 2006, pp.2380-2383, December 2006.
- [9] Chun-Liang HSU, Sheng-Yuan Yang and Wei-Bin Wu, 2009, "Constructing Intelligent Home-Security System Design With Combining Phone-Net And Bluetooth Mechanism", Proceedings of the Eighth International Conference on Machine Learning and Cybernetics, St. John's University, Taiwan.