

# Efficient high speed switching converter for quality arc welding joints for steel pipes

A.Mohammedghouse<sup>1</sup>, M.Ragupathi<sup>2</sup>, S.Viswanathan<sup>3</sup>

S.Rajesh kumar<sup>4</sup>

Department of Electrical and Electronics Engineering

Mangayarkarasi College of Engineering, Madurai, Tamilnadu

***Abstract- using phase inverter full bridge IGBT topology with PWM controller for efficient handling of deliverable heat to the induction heater, for heat treatment of arc welding joints.it is also important to provide the cooling system.so we implement cooling system and auxiliary production mechanism for protecting induction coil. IGBT and other power electronics components. ARM7 based LPC2148 source code for the application will be developed by using KEIL IDE. Due to this advent of power electronics, programming techniques and robust power efficient, high speed, switching devices such as IGBT and MOSFET'S by this induction heating system become more sophisticated. The outcome of the project is expected to deliver the heat in a uniform manner to the job.***

**KEYWORDS: IGBT'S, ARM7, LPC2148 Arc welding, PWM, Induction coil.**

## I. INTRODUCTION

### ***(i) POST HEATING:***

In case of alloy steel materials such as Cr-Mo steels, if the post weld heat treatment is not performed immediately after welding, then the weld joint and adjacent portion of pipe, at least 50 mm on either side of pipe, shall be uniformly heated to 300°C. This temperature shall be maintained for half an hour minimum,

### ***(i) POST WELD HEAT TREATMENT***

Post weld heat treatment, wherever required for joints between pipes, pipes and fittings, pipe body and supports shall be carried out as per the welding specification chart, applicable codes standards and the instructions of the Engineer-in-Charge. In this regard procedure qualification to be done before carrying out PWHT in production welds. Post weld heat treatment shall be done in a furnace or by using an electric resistance or induction-heating equipment, as decided by the Engineer-in Charge. While carrying out local post weld heat treatment, technique of application of heat must ensure uniform temperature attainment at all points of the portion being heat treated. Care shall be taken to ensure that width of heated band over which specified post weld heat treatment temperature attained is at least that specified in the relevant applicable standards/codes. Control of temperature shall be done using microprocessor / computer controlled system. Throughout the cycle of heat treatment, the portion outside the heated band shall be suitably wrapped under insulation so as to avoid any harmful temperature gradient at the exposed surface of pipe. For this purpose temperature at the exposed surface should not be a

llowed to exceed 50%.However, the Engineer-in-Charge can increase the required number of thermocouples to be attached if found necessary. Automatic temperature recorders, which have been suitably calibrated, shall be employed for measuring & recording temperature.

## II. EXISTING SYSTEM

In these system they uses three phase voltage of equal magnitude and frequency. three phase also has higher efficiency and minimum losses. So These three phase ac power is given to three phase full bridge rectifier. The bridge rectifier which converts the ac power into dc power. These dc is now given to HF transformer(high-frequency). High frequency transformer which is small in size and weight but it has the ability to produce frequency from 20khz to 1 MHz due to this advantage of producing high frequency it can be taken into account , those high frequency is given to SR coil which produce enormous amount of heat deliver to the working pieces.

## III. PROPOSED SYSTEM

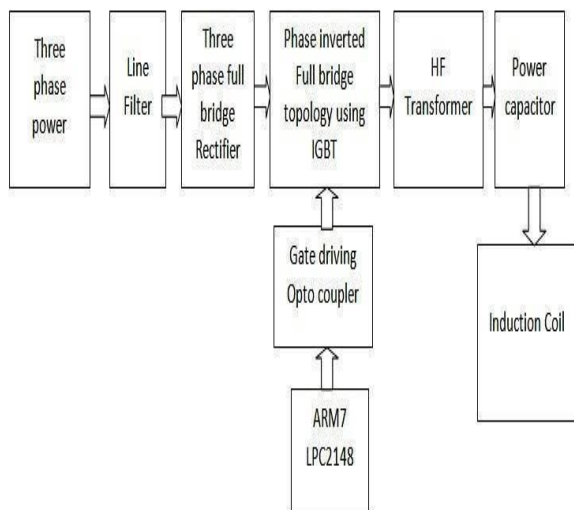

Fig 2.Proposed system

In proposed system the three phase ac supply is taken into the account which is given to three phase full bridge rectifier. Before them it passes to line filter to reduce the harmonics. Bridge rectifier which converts the ac supply into pure dc.This dc supply is given to full bridge IGBT the gate pulses of IGBT is driven by ARM7 LPC2148 microcontroller. Here the optocoupler is used as isolator device. The dc is fed through IGBT and after it converts them into the frequency pulses these modulated pulses is used to drive the HF transformer these high frequency pulses used to produce the enormous amount of heat from the induction coil. In between the power capacitor is used to correct the power factor .those high speed switching device which produce the regulated pulse to the induction coil to produce the suitable amount of heat to the jobs.with out excess and insufficiency of heat.

#### IV. SPECIAL COMPONENTS

ARM- advanced RISC machine is a 32 bit RISC (reduced instruction set computer) processor architecture developed by ARM holding. Many beginners sometimes misunderstood that the ARM is microcontroller are processor but in reality, ARM is an architecture which is used in may processor and micro controllers. The ARM architecture is licensed to companies that want to manufacture ARM based CPU's or system-on-chip products. This enables the companies to develop their own processor compliant either the ARM instruction architecture set for example the device we are using LPC2148 is ARM architecture based socks product developed by NXP semiconductor. Similarly all major semiconductors manufactures like Atmel, Samsung, TI.

They are made by ARM based SOCS.

#### V. CIRCUIT DESCRIPTION

The heart of the circuit is built around ARM7, LPC2148 microcontroller which basically delivers a PWM pulsing for full bridge IGBT inverter topology. ARM7, LPC2148 microcontroller is from NXP and it is a fully robust advanced risk machine based controller much suits our application. It has three built in PWM modules out of which we have used two modules for driving four IGBT's. The IGBT's are switched via opt couplers and the purpose of the opt coupler is to isolation between the controller and the power circuit. The code for the total application has been developed by

KEIL IDE and real view "c" compiler. In this project we maintain PWM frequency of 20 KHZ to switch the

IGBT's and we based on this switching frequency given via power capacitor to maintain the power factor. generated the line filter is used here for EMI (ELECTRO MAGNETIC INTERFERENCE)

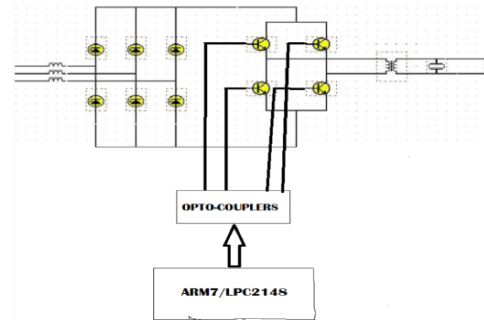

Fig 4.Circuit Diagram

#### VI. ADVANTAGES

Average value proportional; to duty-cycle, this dependence is often to observed follow a linear trend due to previous formulaic definition. so that any industry can buy such systems for its usage. low power consumption, and tie consumption is the main advantage of the system. it also has perfect finishing of the job.

#### VII. CONCLUSION

The induction heater based on high speed PULSE WIDTH MODULATION SWITCHING and IGBT topology is an inevitable power system for delivering optimized power to induction heating coil and its application varies from piping industries, fabrication industries, aerospace industries, ship building industries, scientific development areas, defence and industries we can save power very much and this creates the job work to be less labor intensive and because of the introduction of IGBT'S and three phase rectifier in

these topologies the system is also economic design with sophisticated features many more sectors the PWM controller efficiently handle the power and their by the heat so that the job gets required heat for bending or any type of physical deformation that we want to bring into that object.

Their by the power efficient of the system is taken to very high level and by having such kind of system

### REFERENCES

- 1) Arun kumar paul”Active controlled passive distribution of power offers efficient heat treating solution for quality arc welding joints of steel pipes”,IEEE transaction on industry application ,vol.54,NO.5,sep/oct 2018
- 2) G.Taniguchi & K.Yamashita “Effects of post weld heat treatment (PWHT) temperature on mechanical properties of weld metals for high cr ferritic heat –resistant steel,” rev vol.32,pp.33-39,dec 2013
- 3) C.Chaboudez, S.clain, R.gardon J.Rapaz, M.Swerikosz and R.Touzani “Numerical modelling of induction heating of long work pieces”, IEEE trans magn vol.39,no.6.6pp 5028-5037,nov,1994
- 4) K. Fromger et al.”Industrial heating using energy efficient induction technology”, in proc.int syst,2011,pp1-6.
- 5) S.diekerhoff,M.J.Ryan and R.W.donker. “Design of an IGBT based LCL-resonant inverter for high frequency induction heating” in proc. IEEE Indconf.34<sup>th</sup> IAS anus meeting 1999 pp.2039-2045. appl.