

An Intelligent IOT Enabled Real Time Communication For Vehicular Emergency

Mrs.V.Saraswathi
Department of Computer
Science and Engineering,
S.A.Engineering College
Chennai-600077
TamilNadu

R.Karthick
Department of Computer
Science and Engineering,
S.A.Engineering College
Chennai-600077
TamilNadu

Y.Gokul
Department of Computer
Science and Engineering,
S.A.Engineering College
Chennai-600077
TamilNadu

C.Shashank
Department of Computer
Science and Engineering,
S.A.Engineering College
Chennai-600077
TamilNadu

Abstract— Internet of Things is an prominent term in the technology sector now a days. IOT is the interaction among set of devices connected through a internetwork. IOT makes the human life easy and can also be used for providing assistance during emergency situations faced by the living beings. A system which can provide assistance during vehicular emergencies has been developed. It can automatically detect an accident and can be triggered manually for other vehicular emergencies such as medical emergency, mechanical problems and report it to the rescue centres. Location Tracking is done with the help of GPS and accident is detected using vibration sensor. Node MCU is used for communicating with the server. The proposed paradigm is designed with Arduino UNO R3.

Keywords-Internet of Things (IoT); Global Positioning System (GPS); Arduino UNO R3.

1. INTRODUCTION

IOT is a booming technology which provides a smart approach to carry out the human activities. Using IOT assistance can be provided during emergency situations faced by human beings. Now a days internet has become a common utility among living beings. Almost most of the people are connected to internet. We can build a smart environment by interconnecting people. IOT is one such technology that has the capability to interconnect people through the internet. During an emergency situation while driving a vehicle the proposed system must detect emergencies such as accident automatically using sensors and for other emergencies the system can be triggered manually and report it with the location details to the nearest rescue centres such as hospitals, police stations etc For tracking location in a simplest way Global Positioning system (GPS) can be used.

A. Necessity of Vehicular Emergency Communication System

In a densely populated country like India it is difficult to manage the traffic and road safety. Many people undergo emergency situations while driving a vehicle such as accident, medical emergencies, mechanical problems etc. A survey says most of the people who meets with an accident dies because of the late arrival of the rescue team. It is because the rescue team does not get the intimation as soon as the accident takes place. So the main objective of the project is to provide assistance during an emergency

situation than comes in the way of people travelling in a car. The vehicular emergency system must detect accident automatically and medical emergencies manually triggered by the person and report it to the rescue centres so that we can minimize the aftermath damages of the issues faced.

B. Novelities of the Proposed System

A location tracking system has been developed which when triggered tracks the location of the vehicle and report the details of the vehicle to the rescue centres. Unexpected situations like accidents can be detected automatically by the system and for other emergency situations like medical emergencies, mechanical problems etc the system must be triggered manually. Manually triggering is done with the help of the switches. Accidents are detected automatically by using Vibration sensors. The location is tracked using the GPS and reported to the nearest rescue centre.

2. RELATED WORKS AND RESEARCH

IOT will play a major role in the development of human life. It will be a basic necessity in the near future. Even now various Engineering projects are made using IOT. But those projects are not applied in reality. They still remain as documentation. The future enhancement of IOT will be IOET, that is Internet Of Everything. Few researchers have proved that not only in theory but also these IOT projects can be achieved in reality for example “Padova Smart City project” [10] states that it is possible to build a smart city using IOT which can make the human life easy. In the project “Intelligent alarm system for road collision” [7] the authors have developed a system that tracks location using GPS, that is Global positioning system and sensors. But the problem here is the system is not completely automated. In the “Intelligent transport system” [9] the developers have discussed about the development of intelligent vehicles in the future. These projects gives a detailed idea about how to work on IOT and GPS modules which is used for tracking locations. A developer named C.Thomsan [8] has used sensors in mobile phones or handsets to detect the accident and the collected communication is shared to the rescue centres using 3G connection in mobile phones. But the major drawback of this system is the mobile phone has to be present and it must have proper internet connection.

OnStar of General motors system [6] provides various assistance while driving a vehicle such as route direction and navigation assistance to its customers. It also provides communication facility for emergency situations using the always connected 4G connection. Ford car company also provides some smart assistance using the Ford sync application, which displays emergency phone numbers in the user's smart phone.

3. PROPOSED SYSTEM

The proposed system must detect accident automatically and medical emergencies manually triggered by the person and report it to the nearest hospital, police stations and workshops so that we can minimize the aftermath damages of the issues faced. The fig 1 shows the overview diagram of the proposed system. The overview diagram shows the outline of how the system works. It shows a car on emergency, rescue centres near the car and how the communication is established between the vehicle on emergency and the rescue centres near the vehicle. The rescue centre is chosen according to the type of emergency.

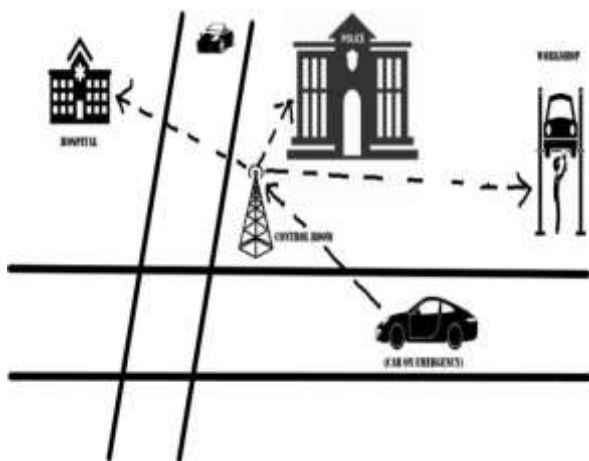

Fig 1: Overview diagram of the system

The development process of the system is split into four important modules, they are as follows:

- Module 1 :Arduino Interfacing With NEO 6M GPS Module
- Module 2 :Arduino Interfacing with Keypad and Force sensor.
- Module 3 :IoT Integration With Server
- Module 4 :Data Visualization through Web Application

A . Details of the system

A location tracking system for vehicular emergency has been developed which tracks the vehicle on emergency and report it to the nearest rescue centres. Rescue centres includes Hospitals, Police stations and Workshops. The system will automatically detect the accident using vibration sensor and can be triggered manually for other

vehicular emergencies. The location of the vehicle is tracked using GPS. The proposed system consists of Arduino UNO R3 with components attached to it. The system detects the accident automatically using vibration sensor and for other emergencies the system must be triggered automatically by the user. Once the system is triggered, it tracks the location of the vehicle using GPS which is connected to the Arduino board . The details of the vehicle and the user is sent to server. An Web application is used to see the details of the emergency vehicle.

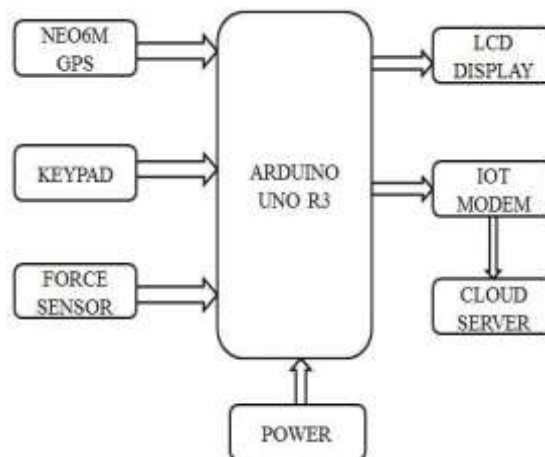

Fig 2: Block diagram of the system

Then the location along with the details of the vehicle and the user is updated in the web application. Using Node MCU the updated details is shared or reported to the nearest rescue centres.

B . Components of the system

The system is built with multiple components which are interconnected to each other. The following components are used :

- ARDUINO UNO R3
- Global Positioning System (GPS)
- Vibration Sensor
- Node MCU
- Push Buttons

The Arduino UNO R3 is a mini computer to which all other components are connected. Neo 6m GPS has been used for collecting the exact location of the vehicle during an emergency situation. The GPS tracks the exact location by the process of triangulation. There are many navigation satellites have been deployed around the Earth's orbit. The GPS receiver must get a message from minimum of three satellites to calculate the location. This process is called as triangulation. The Neo 6m GPS has a flat patch antenna of ceramic and metal body. When the antenna is placed in a position which gives a clear view of sky, the triangulation process takes place and the location is identified. Vibration sensor is used for detecting the

accident. Vibration Sensors detects an accident based of the vibrations that occur during an accident. It has comparator which detects the vibrations. Every vibration sensor has a threshold level. When it observes vibrations above the threshold level the sensor reports an accident. It is communicated to the Arduino UNO R3 and then the system is triggered automatically. The system can also be triggered manually by the user for other emergency situations, for which push buttons are used. Three push buttons has been used and each push button represents a emergency type. The details of the user is stored in the Arduino UNO R3. When the system is triggered Arduino UNO R3 communicates the user details along with the location to the server of the rescue center with the help of the Node MCU. Node MCU is wi-fi enabled and it can also create a HTTP server using the wi-fi station mode. In this mode it will be able to connect to an existing wi-fi network and act as server. An IP address is assigned to it by the network to which it is connected. By using this IP address any wi-fi enabled device can be connected to the server. An HTML page is created for the server which can be used by the rescue centre to visualize the emergency message. Hyper Text Transfer Protocol (HTTP) is the protocol used for communication between the client and the server.

C . Situation Node

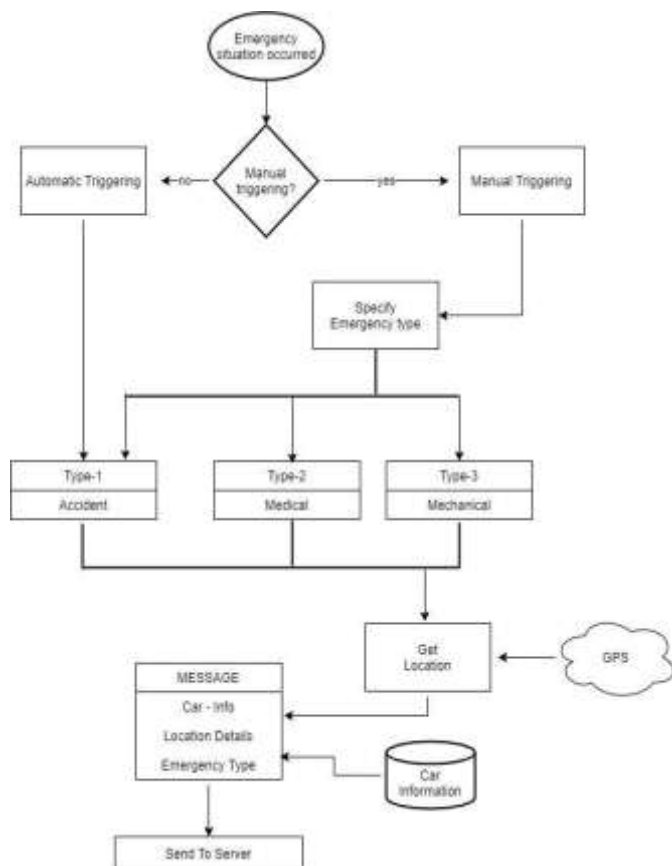

Fig 3 : Architecture Diagram of the system

The system developed consists of Arduino UNO R3 interfaced with components such as GPS, Node MCU, Switches, LCD display, Force sensitive resistor. The working model is fixed inside the vehicle. The vibration sensor detects the accident and the system is triggered automatically. For other emergencies such as medical emergency, mechanical emergencies such as vehicle breakdown, can be triggered manually. For manual triggering the switches in the keypad can be used. Once the system is triggered the system gets the locations coordinates. The location is detected with the help of the GPS. The location details along with the Car information which is predefined is built as a message and sent to the server. The message is sent to the server with the help of the Node MCU.

D . Message Format

The message dialogue consists of seven important fields :

- FIELD 1 : Owner Name
- FIELD 2 : Vehicle Number
- FIELD 3 : Mobile Number
- FIELD 4 : Latitude
- FIELD 5 : Longitude
- FIELD 6 : Date
- FIELD 7 : Time
- FIELD 8 : Emergency Type

VEHICULAR EMERGENCY SYSTEM

OWNER NAME	SHASHANK
VEHICLE_NO	TN 09 1998
MOBILE_NO	7358340801
LATITUDE	13.119973
LONGITUDE	80.145233
DATE	14/10/2020
TIME	11:05:56
EMERGENCY TYPE	ACCIDENT

Fig 4 : Server image of the rescue centre

The server page of the rescue centre contains the emergency message as shown in the Fig 4. It also contains an hyperlink to google maps which shows the location on map with the help of the coordinates communicated to the server by the system developed. Also the server page gets refreshed every ten seconds automatically, which helps the rescue centre get the status on time.

4. RESULT AND DISCUSSION

The proposed system is developed for providing communication facility during an emergency situation. The system is able to send the message to the server and then the message is transferred to the nearest rescue centres. The emergency message contains the type of emergency, location details and the information about the vehicle. The proposed system was developed module wise. The first module was Arduino interfacing with Neo 6m GPS, in this module the GPS was interfaced with the Arduino board. GPS module is used for detecting the location of the vehicle. This module detects the location of the vehicle once the system is triggered. Then in the second module we interfaced the keypad and Vibration sensor with Arduino board. The Vibration sensor is used for detecting the accident and the system is triggered automatically. The force sensor successfully detects an accident and the keypad component consists of switches which can be used for manual triggering. Each switch represents a type of emergency. The Node MCU successfully gets the message from the system and saves the message in the server, then the message is forwarded from the server to the nearest rescue centres. An web application has been created for data visualization.

5. CONCLUSION

A system that provides assistance during vehicular emergencies by tracking the location of the vehicle and by providing communication facility with the rescue centres is developed. This system is specially constructed for smart cities and smart vehicles which has enabled IOT. This prototype can only detect an emergency situation, send emergency message to the nearest rescue centres and cannot provide any help for avoiding the issue. And also this prototype is dependant on several factors such as internet and many electrical & mechanical devices.

6. FUTURE SCOPE

In future with the further development of smart cities across the globe, this system can be enhanced in a way that provides more assistance. Some of the possible future enhancements are :

- Web cameras can be fit inside the vehicle to capture the situation and can be attached along with the message so that the rescue team can understand the situation and come prepared. And it also helps to collect the pictures taken during the time of the accident by which the reason or cause of the accident can be identified.
- Microphone can be fit in the future which can be used for triggering the system manually using voice recognition.

7. REFERENCES

- [1] Subha Koley, Prasun Ghosal, "An IoT Enabled Real-Time Communication and Location tracking System for Vehicular Emergency", vol 1, 2017 IEEE Computer Society Annual Symposium on VLSI
- [2] L. Atzori, A. Iera, and G. Morabito, "The Internet of Things: A Survey," *Computer Networks*, vol. 54, no. 15, pp. 2787–2805, 2010.
- [3] E. A. Lee, "Cyber Physical Systems: Design Challenges," in *Object Oriented Real-Time Distributed Computing (ISORC)*, 2008 11th IEEE International Symposium on. IEEE, 2008, pp. 363–369.
- [4] A. Zanella, N. Bui, A. Castellani, L. Vangelista, and M. Zorzi, "Internet of Things for Smart Cities," *Internet of Things Journal*, IEEE, vol. 1, no. 1, pp. 22–32, 2014.
- [5] "Digital India," Online, 2015, (Last accessed March 18, 2016). [Online]. Available: <http://www.digitalindia.gov.in/>
- [6] R. A. Young, "Association Between Embedded Cellular Phone Calls and Vehicle Crashes Involving Airbag Deployment," in *1st International Driving Symposium on Human Factors in Driver Assessment, Training, and Vehicle Design*, Aspen, CO, 2001, pp. 390–400.
- [7] J. Maleki, E. Foroutan, and M. Rajabi, "Intelligent Alarm System for Road Collision," *Journal of Earth Science and Engineering*, vol. 1, no. 3, 2011.
- [8] C. Thompson, J. White, B. Dougherty, A. Albright, and D. C. Schmidt, "Using Smartphones and Wireless Mobile Sensor Networks to Detect Car Accidents and Provide Situational Awareness to Emergency Responders," in *ICST Conf.*, June, 2010.
- [9] F. J. Martinez, C.-K. Toh, J.-C. Cano, C. T. Calafate, and P. Manzoni, "Emergency Services in Future Intelligent Transportation Systems Based on Vehicular Communication Networks," *Intelligent Transportation Systems Magazine*, IEEE, vol. 2, no. 2, pp. 6–20, 2010.
- [10] A. Cenedese, A. Zanella, L. Vangelista, and M. Zorzi, "Padova Smart City: An Urban Internet of Things Experimentation," in *World of Wireless, Mobile and Multimedia Networks (WoWMoM)*, 2014 IEEE 15th International Symposium on. IEEE, 2014, pp. 1–6.